

## Introduction

This guide briefly describes the XM3.1-HP power supply and provides procedures with regard to the installation of the power supply, battery connection, the Smart Display, initial startup and test, battery configuration and verification of successful installation. For detailed information, refer to the XM3.1-HP Broadband UPS™ Technical Manual available at [www.alpha.com](http://www.alpha.com).

## Audience

This guide is intended for experienced, qualified and licensed installation personnel familiar with the mechanical and electrical requirements of enclosure and power supply systems. Review the support documentation on the website to become familiar with the features and functions of the equipment in this system before proceeding. Failure to install and/or use this equipment as instructed in the system documents can result in a hazard to personnel or damage to the equipment. This system is only serviceable by qualified personnel.

## 1.0 Overview

The Intelligent Broadband UPS™ is comprised of the following:

- A Transformer Module** — Acts as a stand-alone line conditioner. The transformer module contains a ferroresonant transformer, AC oil capacitor, line isolation relay, Power Distribution Module, and EMC Filter board.
- B Intelligent Inverter Module** — Required for standby operations and contains circuitry needed for the three-to-five-stage temperature-compensated battery charger, DC to AC inverter, AC line detectors and Smart Display.
- C Communications Module** — The Communications Module is populated with the Smart AlphaGuard™ (SAG) mounted to the Element Monitoring Module (EMM). The module also contains an embedded Cable Modem Module (CMM) which enables status monitoring and communications. This module may also be referenced as a "transponder" in this guide and supporting technical manuals.

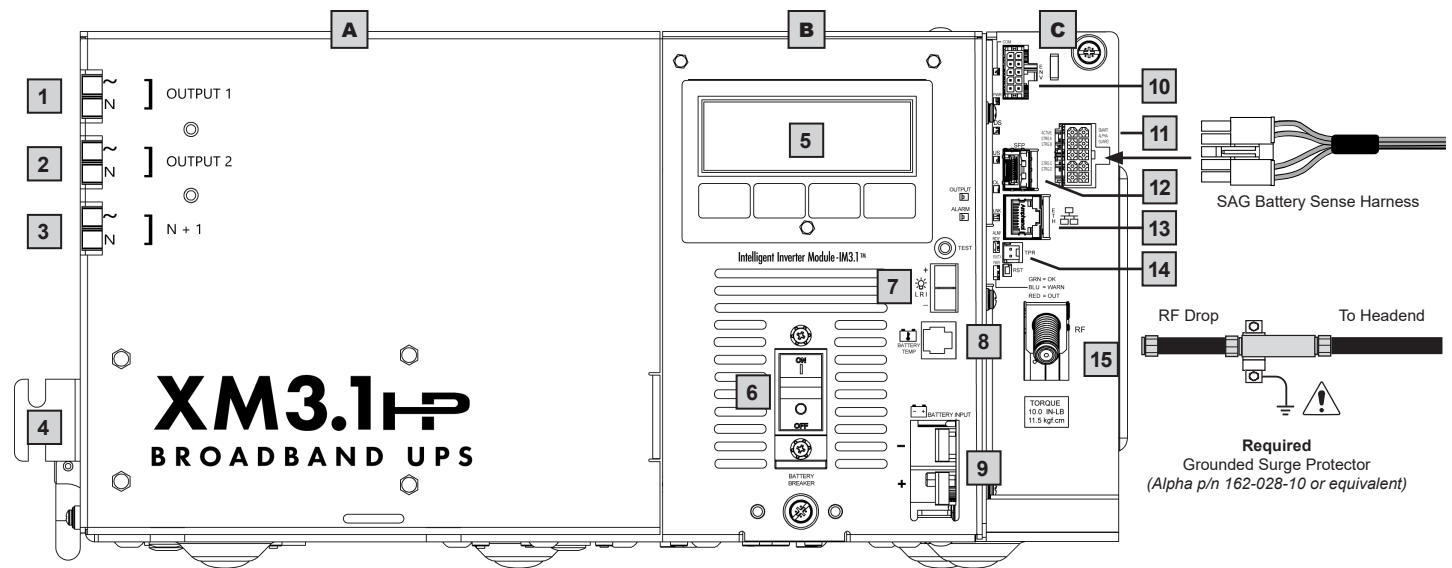

- |  |  |
|--|--|
| <ul style="list-style-type: none"> <li><b>1</b> Output 1 (Primary)</li> <li><b>2</b> Output 2</li> <li><b>3</b> N + 1 Port</li> <li><b>4</b> AC Power Input</li> <li><b>5</b> Smart Display with Softkeys</li> <li><b>6</b> Battery Breaker</li> <li><b>7</b> Local/Remote Indicator (LRI) Connector</li> <li><b>8</b> Precision Temperature Sensor (PTS) Connector</li> </ul> | <ul style="list-style-type: none"> <li><b>9</b> Battery Input</li> <li><b>10</b> Environmental (ENV) Control Connector</li> <li><b>11</b> Smart AlphaGuard (SAG) Connector</li> <li><b>12</b> SFP Optical Status Monitoring Port</li> <li><b>13</b> Ethernet (ETH) Connector</li> <li><b>14</b> Tamper (TPR) Switch Connector</li> <li><b>15</b> RF Connector</li> </ul> |
|--|--|

### NOTICE:

Alpha recommends tightening the RF cable connector and the cables attached to the Grounded Surge Protector to a torque setting of 10in-lb ± 1in-lb.

Fig. 1-1, Main features of the XM3.1-HP Series Power Supply

## 1.1 Communications Module

The Communications Module consists of the Element Monitoring Module (EMM), Cable Modem Module (CMM) and Smart AlphaGuard™ (SAG) battery balancer. The embedded Cable Modem Module (CMM) may be ordered factory-installed or added later to the Inverter Module by qualified personnel or Alpha® Service Depot. The CMM embedded DOCSIS® Status Monitoring unit enables monitoring of Alpha power supplies through existing cable network infrastructure. Advanced networking services provide quick reporting and access to critical powering information.

The CMM utilizes Simple Network Management Protocol (SNMP), standard SCTE-HMS and Alpha Management Information Bases (MIBs) to provide network status monitoring and diagnostics. A web interface enables authorized personnel direct access to advanced diagnostics using a common web browser. This guide pertains to all models and standard options. Refer to the technical manual for additional details on advanced status monitoring using the SFP optical port.

The EMM supports the Smart Display functionality and provides the communication interface between the inverter module and the Cable Modem module. It also supports the necessary data storage and performs optional advanced AlphaAPPs functions such as logging power supply events, utility events, and battery health analysis. Additionally, the EMM provides the interface for the local Ethernet interface and logic for the ancillary equipment such as tamper switches.

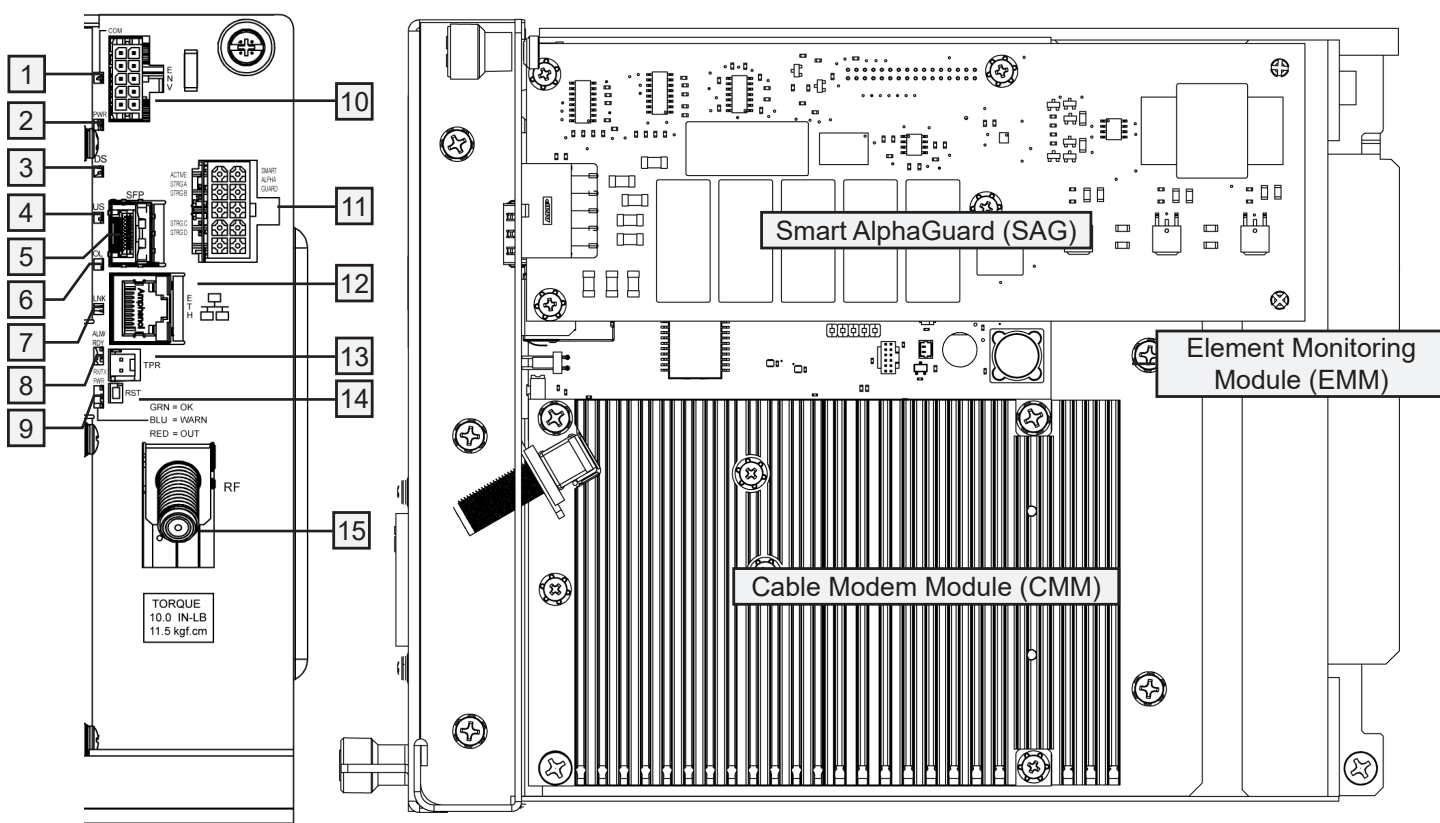

1	COM Indicator LED	6	Online LED	11	Smart AlphaGuard (SAG) Connector
2	Cable Modem Power (PWR) Indicator	7	Ethernet Status LED	12	Ethernet (ETH) Connector
3	Downstream LED	8	Alarm / Ready LED	13	Tamper (TPR) Switch Connector
4	Upstream LED	9	Rx/Tx Power LED	14	Reset Button
5	Small Form-factor Pluggable (SFP) Port	10	Environmental (ENV) Control Connector	15	RF Connector for CMM

Fig. 1-2, Communications Module Features

## 2.0 Battery Installation and Wiring

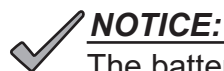

### NOTICE:

The battery terminal hardware is subject to change based on battery make and model.



### WARNING! ELECTRICAL HAZARD

Verify battery voltage, cable color, connection and polarity are correct before proceeding.

Load batteries into cabinet with the positive terminals (+) facing forward. Coat the hardware and battery terminals with an approved battery terminal corrosion inhibitor such as NCP-2® and assemble the cables and hardware as shown in the illustrations below. Torque hardware to 110 in-lbs (12.4 Nm). If M6 hardware is used, torque to 120 in-lbs (15.6 Nm).

With a Midtronics® Conductance meter (Celltron® Essential, Celltron® Advanced or equivalent) measure the conductance value (MHOS) of each battery and record for use in Section 6.2 *Battery Configuration*. Also, record the battery date code on the battery label for entry on the DATE SET screen.

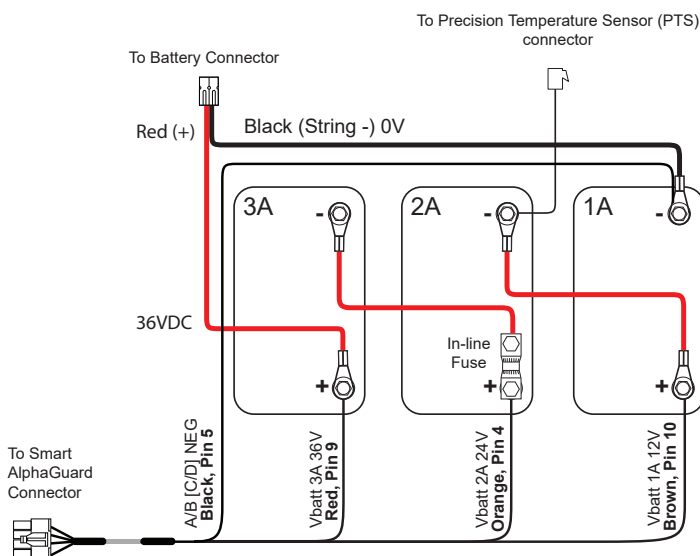

Fig. 2-1, Battery String Wiring Diagram



### CAUTION!

Use 1/4-20 x 3/4" (19 mm) bolts for threaded insert terminals. If using a spacer for the in-line fuse link, use 1/4-20 x 1" (25.4 mm) bolts.

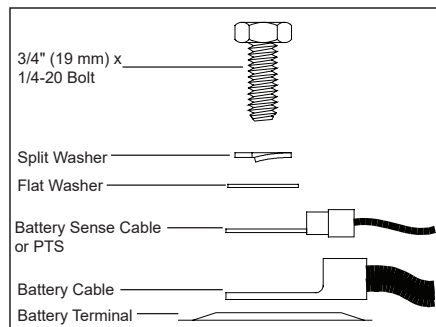

Fig. 2-2, Hardware Stack Up, Non-Fused Connection

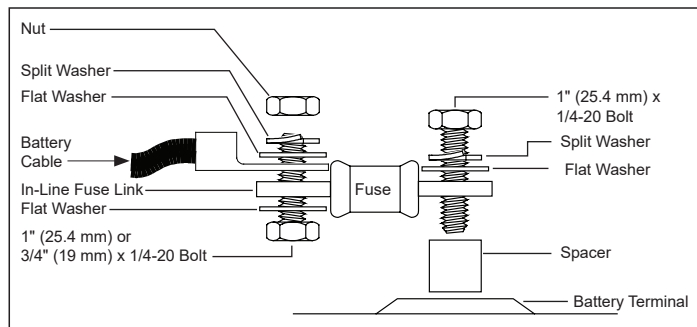

Fig. 2-3, Hardware Stack Up, Fused Connection

## 3.0 Output Voltage Reconfiguration Procedure



### WARNING! ELECTRICAL HAZARD

Before performing this procedure, unplug the Power Supply from the AC power source and batteries.

#### Tools Required:

Small flat-blade screwdriver

1. To access output voltage terminal, remove the Inverter Module.
2. Loosen the terminal screw and move the output voltage wire (Fig. 3-1) to the desired output voltage position on the terminal strip.
3. Torque the terminal block screw to 7 in-lbs (0.79 Nm) to secure the output voltage wire.
4. Reinstall the Inverter Module.

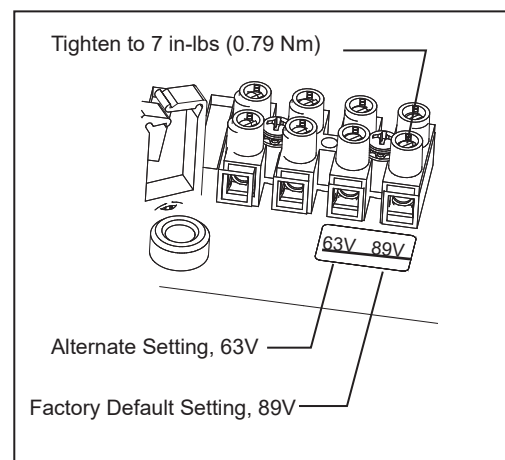

Fig. 3-1, Output Voltage Terminal Positions

## 4.0 Power Supply Connections (Refer to Fig. 1-1)

1. After wiring battery cable kit, battery sense cables and PTS [8], as shown in Section 2, verify DC/Battery breaker [6] is OFF.
2. Connect the Smart AlphaGuard™ (SAG) wire harness to SAG port [11].
3. Connect the Tamper Switch and RF cable to the transponder [13 and 14].
4. Verify the SPI's (Service Power Inserter) **ON / ALT** Toggle Switch is in the **ALT** position.
5. Connect the SPI's input cable to the Output 1 Connector [1]. If a 2nd SPI / ALT Box is present connect input cable to Output 2 Connector [2].
6. Plug the optional Local/Remote Indicator (LRI) cable into the LRI connector [7]. For existing LRI installations, use LRI adapter kit, p/n 875-952-20.
7. Turn AC breaker **ON** and verify it is the correct utility voltage at the outlet (per unit's nameplate voltage). If correct, plug in the XM3.1-HP line cord into the utility outlet.
8. Verify correct battery voltage and polarity on battery cable connector (see Fig. 2-1) with a digital voltmeter; if correct, plug the battery cable connector into Inverter Module [9].

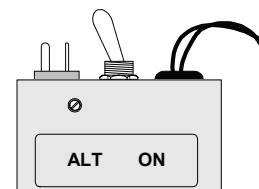

Fig. 4-1, SPI toggle switch (shown in ALT position)

### ✓ NOTICE:

The power supply will boot regardless of the battery breaker position once the batteries are connected. The inverter will not run, but the LCD screen will turn on and display instructions for applying AC power or closing the breaker.

## 5.0 Using the Smart Display

All operational functions, system testing, menus and alarms are available via the illuminated Smart Display. Display functions are accessible by following the indicated prompts above the four softkeys. Descriptions of the display functions are detailed below. Press any of the softkeys to activate the Smart Display. For Smart Display functionality, an EMM module is required to be installed in the Communications Module.

- |   |   |
|---|---|
| 1 | 1st line: Displays Input and Output Voltage/Current   |
| 2 | Describes Power Supply Mode of Operation              |
| 3 | Describes Status of Functions                         |
| 4 | Functionality top level menu PWR, BATT, COMM and APPS |
| 5 | Softkeys (Menu-driven system configuration)           |

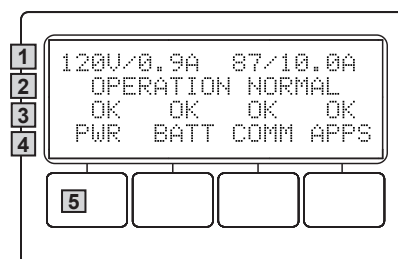

Fig. 5-1, Smart Display with Sample Screen

## 6.0 Startup, Battery Configuration and Self-Test

### 6.1 Initial startup

1. After completing all the steps in Section 4.0, *Power Supply Connections*, turn the DC/Battery breaker [6] ON. The Smart Display will cycle through its functions (approximately 60 seconds) verifying proper operation. During this time, the XM3.1-HP may perform an automatic 5 second Self-Test to verify whether a battery string is connected to the power supply system by checking the battery string voltage. Upon successful completion, the Smart Display will indicate **“OPERATION NORMAL”**. From this screen, proceed to Section 6.2, *Battery Configuration*.
2. If power supply alarms are present and do not clear after 60 seconds, press the softkey associated with the alarm to see the ACTIVE ALARM list.
3. Press **UP↑** or **DOWN↓** to select the active alarm.
4. Press **ENTR** to select the alarm and display diagnostic information. Press **ESC** to return to the alarm list. Refer to the XM3.1-HP Power Supply Technical Manual for a complete listing of alarm conditions and recommended diagnostic solutions.
5. Once the alarm has been cleared, the batteries can be configured in the system as outlined in the next section.

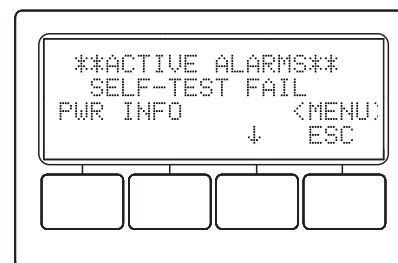

Fig. 6-1, Smart Display indicating a Self-Test Fail Alarm

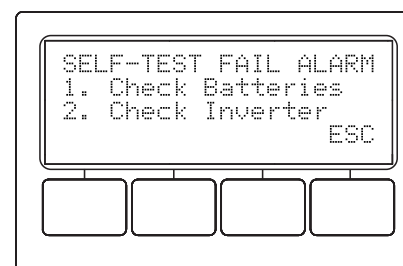

Fig. 6-2, Self-Test Fail Alarm Menu, with suggestions for corrective actions

## 6.2 Battery Configuration

1. From the Operation Normal screen, press the **BATT** softkey to open the BATTERY INFO menu.
2. Press **ENTR** to open BATT CONFIG Menu. The BATT MHOS screen opens\*; press **ENTR** to access the first battery in the string, for example, (A1). The first digit will be cycling on and off. Press the **UP** arrow key to set the value of each digit as recorded at the time the batteries were installed. Once the correct value is set, press **ENTR** to advance to the next digit. Use the **UP** arrow key as before to set the value. Repeat for each following digit. When complete, press **ENTR** to return to the BATTERY MHOS screen. Press the **DOWN** arrow key to select the next battery in the string and repeat the MHOS setting process.
3. Once the MHOS values for each battery have been set, press **ESC** to return to the BATTERY CONFIG MENU.
4. Press the **DOWN** arrow key to select the next line item for adjustment: BATT DATES.
5. Press **ENTR** to select battery and advance to DATE SET screen. Press **ENTR** to select Batt A1 date. Select **ENTR** and key in the dates recorded from the battery labels at the time of installation. Press **ESC** to return to the DATE SET screen and the down arrow to select the next battery. Repeat the above steps for each remaining battery.
6. Press **DOWN** arrow softkey and select BATT MODEL and from the submenu, select the battery type installed.
7. Press **ENTR** to return to the Battery Config menu and select NUM BATT STRINGS and enter the correct value.
8. Press **ENTR** to accept new data.
9. Press **ESC** to return to the OPERATION NORMAL screen.
10. Switch SPI/ALT **ON** and verify the XM3.1-HP is supplying to the load.

\* Battery MHOs and Date code should only be set after the transponder is online, as indicated by the "OL" LED showing a steady ON state.

## 6.3 Self-Test Operation

The power supply should be operating correctly with no alarms present. Use the Smart Display to verify Normal and Communication Information. Verify Test Duration setting in the PWR CNFG menu screen.

1. Press and hold the **TEST** button for 1 to 2 seconds to start self-test. The test will run for a preset time (5-180 minutes, set in the PWR CNFG Menu). Self-test can also be entered by setting self-test to ON in the PWR CNFG Menu. Additionally, the self-test can be configured to perform a deep-discharge of 10%, 20%, 30%, 40% and 50% of battery capacity. When the deep discharge is complete, it will revert back to the Timed Test.

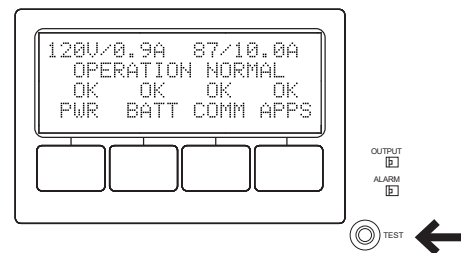

Fig. 6-5, Test Button

Condition	Output LED	Alarm LED
Normal Operation	On	Off
Minor Alarm	Flash	Off
Major Alarm	Flash	Flash
Output Off	Off	Flash

Table 6-1, Alarm Indicators

### ✓ NOTICE:

A Self-Test Fail alarm will be activated and appear on the Smart Display and Transponder web page if the XM3.1-HP detects one or more defective battery strings or problem with the Inverter Module. Replace batteries or module as required. This is a latched alarm and power cycling the Inverter Module will not clear the alarm. This alarm can only be cleared by successfully running in self-test for a minimum of one minute.

### ✓ NOTICE:

For power supply installations that may not have utility power available due to new construction or extended service interruptions, it is recommended to disconnect the batteries from the power supply until the site is fully functional. It is not recommended to have the power supply battery circuit breaker in the off position with batteries connected and no utility power connected for extended periods of time. A warning will display on the Smart Display when this condition is detected.

### 6.3 Self-Test Operation, *continued*

- While in self-test mode, use the Smart Display or a true RMS voltmeter to verify output. Output voltages should appear within the ranges shown in Table 6-2.
- To halt/cancel a self-test in progress, press and hold the **TEST** button for one to two seconds or change self-test to OFF in the Power Config Menu.
- After successful completion of the self-test, perform a Standby Test by shutting off the utility breaker and verifying the Power Supply goes into STANDBY MODE and supports the load.
- After the Standby test, reapply AC voltage and verify the unit transfers back to LINE MODE.

Voltage Regulation (% Range)		
Voltage Setting	Fine (-2.5%/+1%)	Coarse (-5%/+1%)
89VAC	86.77VAC / 89.89VAC	84.6VAC / 89.89VAC
63VAC	61.43VAC / 63.63VAC	59.85VAC / 63.63VAC

Table 6-2, Voltage Regulation

## 7.0 Alpha® DOCSIS® 3.1 Transponder and Smart AlphaGuard™ LEDs

### 7.1 Verify Smart AlphaGuard™ operation as indicated below:

Smart AlphaGuard™ LED State and Indications			
LED Name	Color	State	Indication
Active	Green	Off	No power to SAG
		Solid	Unit is on and communicating with power supply or in Rest mode
		Flash (50% on / 50% off)	Actively balancing
		Flash (10% on / 90% off)	Powersave mode
STRG A STRG B STRG C STRG D (ALARMS)	Red	Off	Normal operation
			String X not present
		Flash (50% on / 50% off (Minor Alarm)	High delta mean
		Solid (Major Alarm)	Check battery alarm
		All flash (10% on / 90% off)	String X missing
			Stuck relay detected

Table 7-1, Smart AlphaGuard LEDs

### 7.2 Verify Transponder Operation

Verify the CMM LEDs behavior is as follows:

CMM Rx and Tx LED Indications					
Step	Communications State	Downstream (DS)	Upstream (US)	Online (OL)	Rx/Tx Power
1	Transponder Initializing/Searching for Downstream DOCSIS® channel(s)	Flashing	OFF	OFF	OFF
2	Downstream channel(s) locked, searching for upstream channel(s)	ON	Flashing	OFF	ON (Green)
3	Upstream channel(s) locked, registering with CMTS	ON	ON	Flashing	ON (Green)
4	CMM fully functional, registration complete	ON	ON	ON	ON (Green)

Table 7-2, Transponder LEDs

When the CMM is fully functional (step 4 in the table above), the Rx/Tx Power LEDs indicate the RF power levels as follows:

- \* Blue RF LED indicates Rx/Tx Power at a warning level. Make the necessary RF level adjustments.
- \* Red RF LED indicates Rx/Tx Power at an alert level. Make the necessary RF level adjustments.

LED Color	Default Rx Range (dBmV)	Default Tx Range (dBmV)
Green	+10 to -10	0 to +50
* Blue	+15 to +10 and -10 to -15	+50 to +55
* Red	>+15 and <-15	>+55

Table 7-3, Rx/Tx LEDs

## 7.3 XM3.1-HP Smart Display — COMM Menu

Verify Alpha® DOCSIS® Transponder communication parameters such as IP Address, RF Power Levels and Signal/Noise Ratio on the COMM menu of the XM3.1-HP Smart Display. Press **ENTR** to open the RF-GENERAL Menu enabling the operator to view values for the following parameters. Pressing the **UP** or **DOWN** arrow softkeys will show two lines of information for each submenu item.

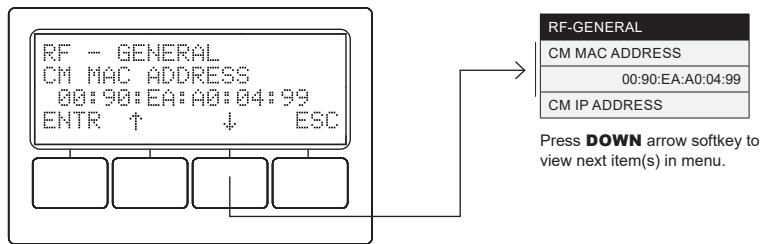

Fig. 7-1, Navigating to CM MAC Address

## 8.0 Final Verification

### 8.1 Local Web Server Access

The Ethernet port of the Alpha DOCSIS Transponder can be used as a local connection point, allowing the user to connect to the transponder web page.

To access the web page, follow the steps below:

#### ✓ **NOTICE:**

A Static IP address (192.168.100.2) may need to be set on your network interface card to connect to the transponder.

1. Using a standard (CAT 5e or better) Ethernet cable, connect the transponder to the laptop or computer network interface port.
2. Launch a web browser.
3. Enter the transponder's default IP address (192.168.100.1) into the web browser's address field.
4. The transponder's web server home page will appear.

#### ✓ **NOTICE:**

For the Alpha DOCSIS Transponder, this may take up to 45 seconds when the transponder is initially powered up with no RF connection.

### 8.2 Remote Web Server Access

To remotely access the Alpha DOCSIS Transponder web server utilizing a web browser:

1. Open a web browser on a computer connected to the same network as the XM3.1-HP.
2. Enter the Alpha DOCSIS Transponder's designated IP address (e.g., 192.168.1.124) into the web browser address field.
3. The Alpha DOCSIS Transponder's web server home page will appear.

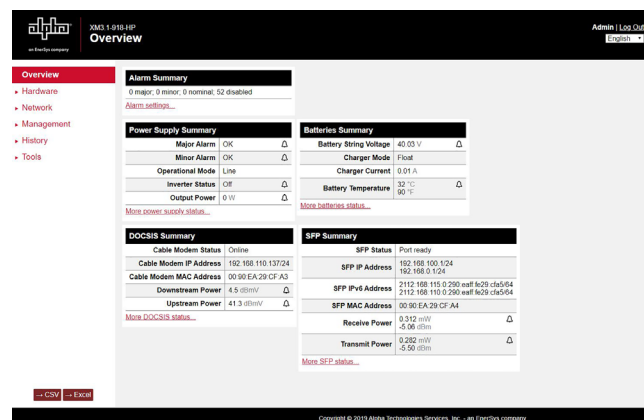

Fig. 8-1, Transponder Home Page (sample data only)



an EnerSys® company

Alpha Technologies Services, Inc. | 3767 Alpha Way, Bellingham, WA 98226, USA

Tel.: Toll Free North America: +1 800 322 5742 | Outside US: +1 360 647 2360 | Technical Support: +1 800 863 3364

For more information visit our website at: [www.alpha.com](http://www.alpha.com)

© 2020 Alpha Technologies Services, Inc. All Rights Reserved. Trademarks and logos are the property of Alpha Technologies Services, Inc. and its affiliates unless otherwise noted. Subject to revisions without prior notice. E.&O.E. DOCSIS is a registered trademark of Cable Television Laboratories, Inc. NCP-2 is a registered trademark of The NOCO Company. Midtronics is a registered trademark of MIDTRONICS, INC. CELLTRON is the registered mark of Celltron, Inc.

017-950-B1-001, Rev. A (07/2020)