

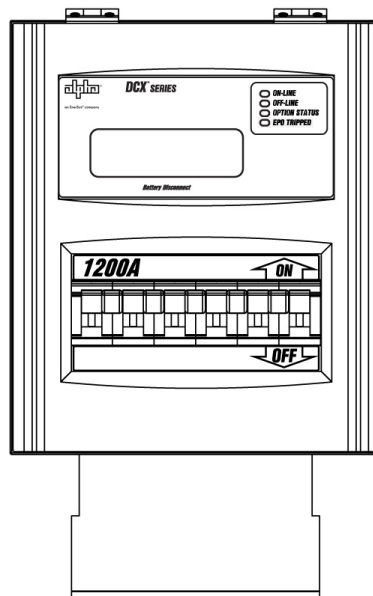

an EnerSys® company

DCX™ Series Top Terminal Battery Disconnect System Installation and Operation Manual

Effective: January 2021



Safety Notes

Alpha Technologies Services, Inc. considers customer safety and satisfaction its most important priority. To reduce the risk of injury or death and to ensure continual safe operation of this product, certain information is presented differently in this manual. Alpha® tries to adhere to ANSI Z535 and encourages special attention and care to information presented in the following manner:



WARNING! GENERAL HAZARD

GENERAL HAZARD WARNING provides safety information to PREVENT INJURY OR DEATH to the technician or user.



WARNING! ELECTRICAL HAZARD

ELECTRICAL HAZARD WARNING provides electrical safety information to PREVENT INJURY OR DEATH to the technician or user.



WARNING! FUMES HAZARD

FUMES HAZARD WARNING provides fumes safety information to PREVENT INJURY OR DEATH to the technician or user.



WARNING! FIRE HAZARD

FIRE HAZARD WARNING provides flammability safety information to PREVENT INJURY OR DEATH to the technician or user.

There may be multiple warnings associated with the call out. Example:



WARNING! ELECTRICAL & FIRE HAZARD

This WARNING provides safety information for both Electrical AND Fire Hazards



CAUTION!

CAUTION provides safety information intended to PREVENT DAMAGE to material or equipment.



NOTICE:

NOTICE provides additional information to help complete a specific task or procedure.

ATTENTION:

ATTENTION provides specific regulatory/code requirements that may affect the placement of equipment and /or installation procedures.

The following sections contain important safety information that must be followed during the installation and maintenance of the equipment and batteries. Read all of the instructions before installing or operating the equipment, and save this manual for future reference.

DCX™ Series

Top Terminal Battery Disconnect System Installation and Operation Manual

C048-699-30 R03, Rev. B

Effective: January 2021

© 2021 by Alpha Technologies Services, Inc.

Disclaimer

Images contained in this manual are for illustrative purposes only. These images may not match your installation. Operator is cautioned to review the drawings and illustrations contained in this manual before proceeding. If there are questions regarding the safe operation of this powering system, please contact Alpha Technologies Services, Inc. or your nearest Alpha representative.

Alpha® shall not be held liable for any damage or injury involving its enclosures, power supplies, generators, batteries or other hardware if used or operated in any manner or subject to any condition not consistent with its intended purpose or is installed or operated in an unapproved manner or improperly maintained.

Contact Information

Sales information and customer service in USA
(7AM to 5PM, Pacific Time):

1 800 322 5742

Complete Technical Support in USA
(7AM to 5PM, Pacific Time or 24/7 emergency support):

1 800 863 3364

Sales information and Technical Support in Canada:

1 888 462 7487

Website:

www.alpha.com

Contents

1.0 Purpose and Applicability	5
1.1 Product Model	5
2.0 Theory of Operation	5
2.1 Circuit Breaker Trip Ratings	5
2.2 Mounting Configurations	5
2.3 Monitoring Options	6
3.0 Unpacking and Inspection	6
3.1 Package Contents	6
4.0 Installation	6
4.1 Installation Kit Options	6
4.2 Installation Preparation	7
4.2.1 Elevated Operating Ambient	7
4.2.2 Reduced Air Flow	7
4.2.3 Mechanical Loading	7
4.2.4 Circuit Overloading	7
4.2.5 Reliable Earthing	7
4.2.6 Disconnect Device	7
4.3 Battery Top Terminal Mount	8
4.3.1 Termination Bus Assembly	8
4.3.2 Battery Top Mounting Brackets	9
4.4 Chassis Ground	10
4.5 Battery Positive Connection	11
4.6 EPO Emergency Power Off Switch Option	11
4.7 Alarm Contacts	11
4.8 Auxiliary Power Port	11
4.9 Electrical Test	11
4.10 Output Connections	12
4.11 Safety Covers	13
4.12 Fuse Replacement	13
5.0 Product Specifications	14
6.0 Models and Accessories	15
Appendix A: Mechanical Drawings	17
A.1 DCX Battery Disconnect Isometric View	17
A.2 DCX Battery Disconnect Dimensions	18
A.3 DCX Chassis Ground Locations	19

1.0 Purpose and Applicability

This document covers the installation and operation of the DCX™ Series top terminal battery disconnect system.

1.1 Product Model

This document applies to Alpha products in the following model configurations:

Table 1. DCX Model Configurations - Switch Only Versions (No Current Limiting)

DESCRIPTION	PART NUMBER
400A DCX Battery Disconnect; -48VDC; w/shunt	C016-1001-10
600A DCX Battery Disconnect; -48VDC; w/shunt	C016-1003-10
800A DCX Battery Disconnect; -48VDC; w/shunt	C016-1005-10
1000A DCX Battery Disconnect; -48VDC; w/shunt	C016-1007-10
1200A DCX Battery Disconnect; -48VDC; w/shunt	C016-1009-10

Table 2. DCX Model Configurations - Magnetic Trip Versions

DESCRIPTION	PART NUMBER
400A DCX Battery Disconnect; -48VDC; w/shunt	C016-198-10
600A DCX Battery Disconnect; -48VDC; w/shunt	C016-195-10
800A DCX Battery Disconnect; -48VDC; w/shunt	C016-199-10
1000A DCX Battery Disconnect; -48VDC; w/shunt	C016-196-10
1200A DCX Battery Disconnect; -48VDC; w/shunt	C016-207-10

For a list of mounting kit and accessory part numbers, refer to Section 6 on Page 17.

2.0 Theory of Operation

The DCX disconnect product family includes multiple amperage ratings and installation mounting schemes to provide a DC or Battery source disconnect device for use in Telecom +24 or -48VDC systems as well as solar-alternate energy or other DC applications. The primary application for the DCX system is to provide over-current protection for battery sourced equipment and wiring. The secondary function is to provide a service disconnect in order to maintain batteries or to shut down the battery source connection in an emergency.

2.1 Circuit Breaker Trip Ratings

The DCX product family includes circuit breaker trip ratings of 400, 600, 800, 1000, and 1200A. The electrical configuration allows for both positive and negative connected systems as factory configured options. The DCX system includes a circuit breaker or switch, an internal input and output copper bus structure, a steel inner housing, a circuit board, and a flame retardant plastic outer housing.

2.2 Mounting Configurations

Several different mounting bracket option kits provide battery top terminal mounting configurations for numerous battery manufacturer's cell configurations.

2.3 Monitoring Options

The DCX battery disconnect system includes monitoring features for local and remote status indication:

LED indicators “ON-LINE”, “OFF-LINE”, “ALARM/FAULT”, “EPO TRIPPED” (see Figure 1). Alarm contacts: Form-C relay contacts to provide breaker trip status.

- **ON-LINE:** The battery string is connected – circuit breaker/switch is ON.
- **OFF-LINE:** The battery string is disconnected – circuit breaker/switch is OFF.
- **ALARM/FAULT or OPTION STATUS** – provides information for any installed option, such as the TRD VRLA Battery Thermal Runaway Detection System
 - NO LIGHT:** No option is installed
 - GREEN LIGHT:** Option is installed and working normally
 - RED LIGHT:** Option is in alarm (for more information, refer to the installed option's manual)
- **EPO TRIPPED** – Emergency Power Off input is active. This indicator is not persistent.



Figure 1. LED Indicators

3.0 Unpacking and Inspection

The DCX battery disconnect system is shipped in a box that includes protective inserts for the main DCX housing as well as the mounting bracket component set and related hardware.

Inspect the outer box immediately after receipt as well as the contents to confirm that there is no shipping damage. Most shipping carriers require notification within 24 hours of delivery of any shipping damage in order to cover the cost of the damage via repair or replacement. It is the responsibility of the recipient to inspect the shipment immediately upon receipt.

Remove the DCX unit and related brackets and hardware and confirm that the components are present. Refer to the mounting kit instruction sheet that comes with the shipment and is specific to the mounting kit option that was ordered to confirm that all parts are present for installation.

The plastic flip-up front panel and the plastic housing of the DCX unit are not designed as structural components so be careful to lay the unit on its side or back temporarily until it is mounted to the mounting bracket set to avoid damage.

Arrange the mounting bracket kit including hardware for preparation for installation at the install location.

3.1 Package Contents

- DCX™ Series top terminal battery disconnect unit (Figure 2, A.)
- Battery mounting kit with hardware (ordered separately)
 - Mounting bracket(s) (Figure 2, B.)
 - Copper battery termination bus (Figure 2, C)

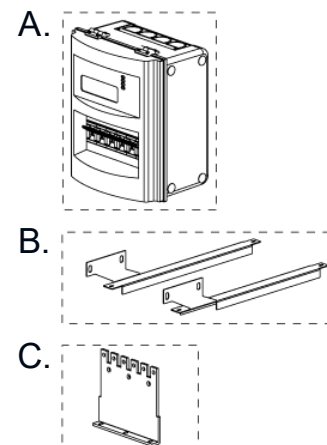

Figure 2. Package Contents

4.0 Installation

4.1 Installation Kit Options

Refer to Section 6 on Page 15 for ordering information.

Battery top terminal mount installation kits for the DCX battery disconnect system are available for the following battery manufacturers:

- **EnerSys®**
- **C&D Technologies®**
- **GNB®**
- **East Penn Manufacturing**

4.2 Installation Preparation



NOTICE:

THIS PRODUCT MUST BE INSTALLED WITHIN A RESTRICTED ACCESS LOCATION WHERE ACCESS IS THROUGH THE USE OF A TOOL, LOCK AND KEY, OR OTHER MEANS OF SECURITY, AND IS CONTROLLED BY THE AUTHORITY RESPONSIBLE FOR THE LOCATION. THIS PRODUCT MUST BE INSTALLED AND MAINTAINED ONLY BY QUALIFIED TECHNICIANS.

4.2.1 Elevated Operating Ambient

If you install the unit in a closed or multi-unit rack assembly, the operating ambient temperature of the rack environment may be greater than room ambient. Therefore, take care to install the equipment in an environment compatible with the maximum ambient temperature (TMA).

4.2.2 Reduced Air Flow

Installation of the equipment in a rack should be such that the amount of air flow required for safe operation of the equipment is not compromised.

4.2.3 Mechanical Loading

Mounting of the equipment in the rack should be such that a hazardous condition is not achieved due to uneven mechanical loading.

4.2.4 Circuit Overloading

Give consideration to the connection of the equipment to the supply circuit and the effect that overloading of the circuits might have on overcurrent protection and supply wiring. Use appropriate consideration for equipment nameplate ratings when addressing this concern.

4.2.5 Reliable Earthing

Maintain reliable earthing of rack-mounted equipment. Pay particular attention to supply connections other than direct connections to the branch circuit (e.g., use of power strips).

4.2.6 Disconnect Device

A readily accessible disconnect device must be incorporated into the building installation wiring.

4.3 Battery Top Terminal Mount

4.3.1 Termination Bus Assembly



CAUTION!

ENSURE BATTERY STRING IS NOT COMPLETELY CONNECTED IN SERIES PRIOR TO THE INSTALLATION OF THE DCX UNIT FOR SAFETY PURPOSES. DISCONNECT SEVERAL SERIES BUS CONNECTIONS OF THE STRING TO ENSURE THE TOP NEGATIVE TERMINAL IS NOT CONNECTED TO THE REST OF THE STRING SO THAT THE INSTALLATION WORK CAN BE DONE SAFELY WITHOUT VOLTAGE PRESENT. ENSURE THAT ALL THE PLASTIC CELL TERMINAL COVERS ARE INSTALLED TO PREVENT ACCIDENTAL CONTACT OR SHORT CIRCUIT OF THE STRING TERMINALS WITH TOOLS ETC. DURING THIS INSTALLATION PROCESS.

The DCX unit ships without the battery termination bus installed and will require assembly. The termination bus hardware comes pre-installed on the DCX and requires removal before terminal plate can be installed. Follow the steps below for termination bus installation instructions.

Step 1. Flip up the front hinged lid, then remove the lexan breaker cover by removing the phillips-head screws as shown in Fig. 3.

Step 2. Remove the 3/8 in. socket head cap hardware from the bottom of the circuit breaker as shown in Fig. 4.

Step 3. Remove the three pre-installed phillips-head screws from the glastic isolators as shown in Fig. 5.

Step 4. Insert the termination plate into the slot located on the bottom of the DCX battery disconnect chassis as shown in Fig. 6.

Step 5. Reinstall the three phillips-head screws into the glastic isolators from Step 3.

Step 6. Reinstall the 3/8 in. socket head cap hardware into bottom of the circuit breaker from Step 2 (recommended torque value: 225 in-lbs). Ensure the ring terminal (blue wire) on the furthest breaker pole to the right is secured between the 3/8 in. socket head cap screw hardware and the DCX termination plate as shown in Figure 7.

Table 3. Termination Plate Torque Specifications

TERMINATION TYPE	HOLE/STUD SIZE	RECOMMENDED TORQUE VALUE
Threaded Insert	3/8 in.	18.75 ft·lbs

Step 7. Reinstall the lexan breaker cover from Step 1 by reinstalling the phillips-head screws.

Step 8. Close the hinged lid.

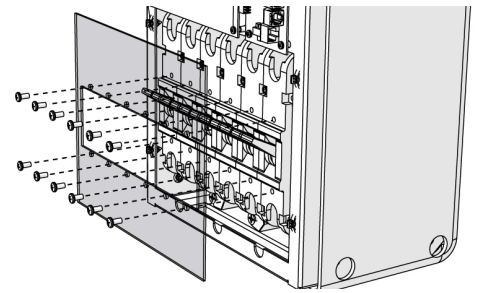

Figure 3. Lexan breaker cover

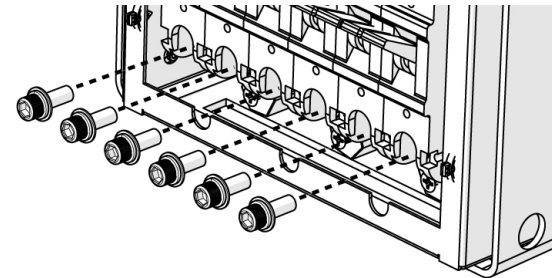

Figure 4. 3/8 in. socket head hardware

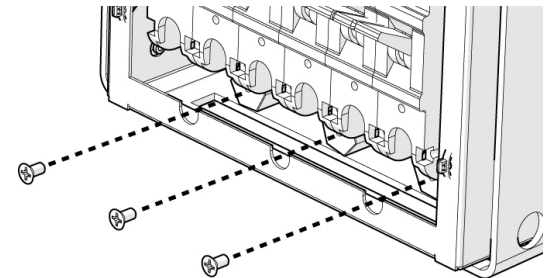

Figure 5. Phillips head screws

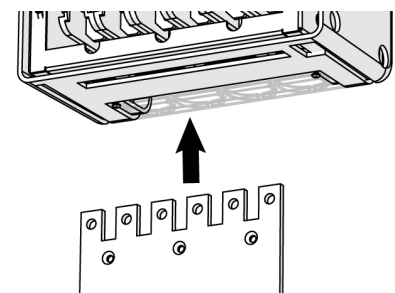

Figure 6. Termination Bus

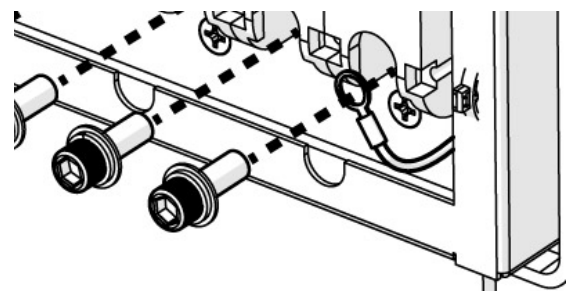

Figure 7. Reinstall socket head hardware

4.3.2 Battery Top Mounting Brackets



WARNING! ELECTRICAL HAZARD

MULTIPLE POWER SOURCES ARE PRESENT. ENSURE ALL INPUT POWER FEEDS ARE NOT ENERGIZED BEFORE INSTALLING THEM. ELECTRICAL INSTALLATION SHOULD ONLY BE PERFORMED BY QUALIFIED PERSONNEL WITH PROPER TOOLS AND PROTECTIVE SAFETY EQUIPMENT.



NOTICE:

MULTIPLE DCX MOUNTING KIT CONFIGURATIONS EXIST. THE ILLUSTRATIONS AND INSTRUCTIONS DEPICTED MAY NOT ACCURATELY REFLECT YOUR SELECTED CONFIGURATION.



CAUTION!

DO NOT DRILL MOUNTING HOLES DIRECTLY ABOVE EACH BATTERY CELL – THE CELL WILL BE PUNCTURED.

The DCX Series chassis includes mounting provisions for mounting brackets to secure into place on top of the battery stack. Note that the mounting location and terminal plate are configured for the -48VDC output terminals located on the top battery of the battery string.

For C&D Technologies®, GNB®, and East Penn Manufacturing batteries, ensure that the battery bus bar kit included with the battery is configured for the -48V output to be the center top battery for direct bolted connection to the DCX.

For EnerSys® batteries, ensure that the battery bus bar kit included with the battery is configured for the -48V output to be the center top battery (3x8 stack configurations) or the rightmost top battery (4x6 stack configurations).

The DCX mounting brackets will require finger tight installation onto the DCX to properly allow marking for self-tapping screw locations (EnerSys/C&D/GNB mounting bracket kits) or for 1/4 in. X 20 threaded insert locations found on the front of mounting brackets (East Penn mounting bracket kits). Brackets will then require removal from the DCX so that they can be secured into place onto the battery stack frame followed by reinstallation of the DCX.

NOTE: the mounting brackets for East Penn Manufacturing batteries each have a 1/4 in. x 20 threaded insert installed where the bracket seats inside of the cell module U-channel that runs left to right on top of the cell module.

- Step 1.** Use the 3/8 in. bolts and washers included in the hardware kit to install the left and right mounting brackets via the slots in the underside of the DCX unit. Tighten the two bolts per side finger tight for alignment later. Refer to Figure 8 and 9.
- Step 2.** Position the DCX unit on top of the cell module over the -48VDC battery terminals on the top battery of the battery string. Carefully bolt the negative terminal posts to the holes in the DCX termination plate finger tight with the 1/4 in. x 20 bolts provided with the battery pack. Adjust the 3/8 in. bolts on the DCX mounting brackets to allow the DCX unit to adjust vertically via the bolt slots in the brackets. Adjust the DCX unit up and down to ensure that it is perpendicular to the battery module and that the termination plate seats on the battery terminals properly.

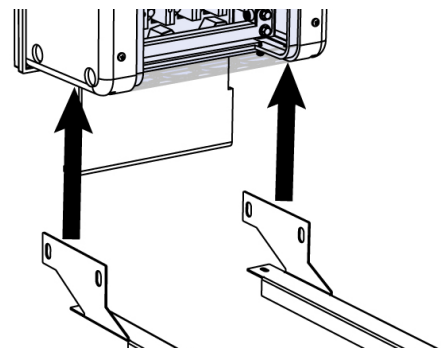

Figure 8. DCX mounting bracket slots

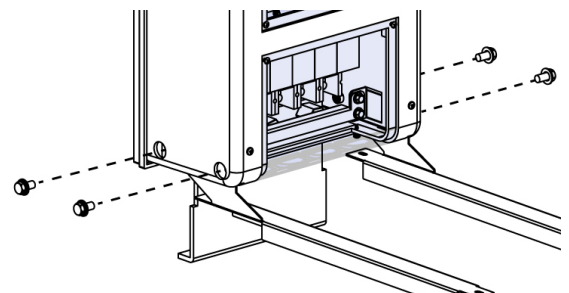

Figure 9. DCX mounting bracket

Step 3. Once the DCX unit is in its final position, mark the DCX mounting bracket hole locations onto the battery stack frame top rails (see Figure 10).

Step 4. Uninstall the termination plate from the battery terminals, then uninstall the DCX mounting brackets from the DCX unit.

Step 5. Align the DCX mounting brackets with the marked locations from Step 3 and secure into place by tightening the included self-tapping screws (EnerSys/C&D/GNB battery kits, Figure 11) or by tightening the included 1/4 in. hardware into the threaded inserts of the mounting brackets (East Penn Manufacturing kits).

Step 6. Reinstall the DCX unit into position again as described in Step 2, then tighten all hardware. See Table 4 for DCX mounting bracket to DCX chassis torque specifications.

NOTICE:
NOTE: REFER TO BATTERY MANUFACTURER TORQUE SPECIFICATIONS FOR TIGHTENING BATTERY TERMINATION PLATE TO BATTERY TERMINAL POSTS (FIGURE 12).

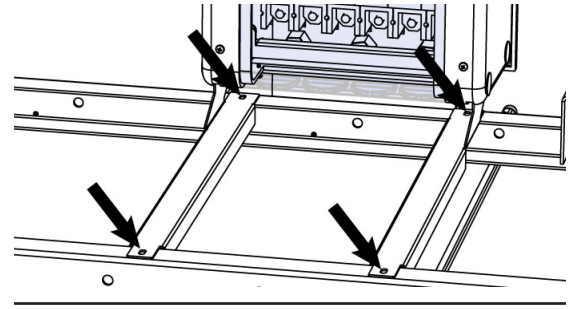

Figure 10. Mark bracket locations

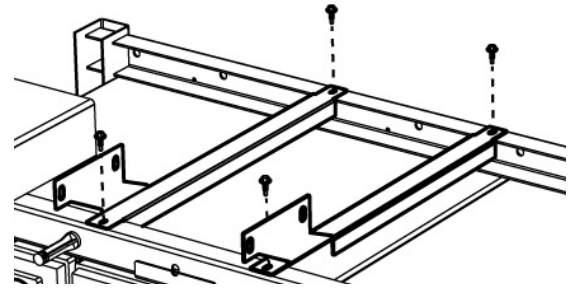

Figure 11. Secure brackets

Table 4. Mounting Bracket to DCX Chassis Torque Specifications

TERMINATION TYPE	HOLE/STUD SIZE	RECOMMENDED TORQUE VALUE
Threaded Insert	3/8 in.	50 in·lbs

Step 7. After mechanical mounting of DCX unit has been completed, snap the two black plastic hole plugs into the access holes that cover the 3/8 in. mounting bolts (see Figure 13)

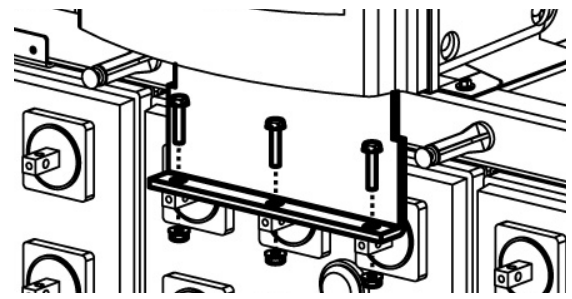

Figure 12. Secure to cell terminals

4.4 Chassis Ground

CAUTION!
DO NOT ENERGIZE THE DCX BATTERY DISCONNECT SWITCH BEFORE CHASSIS GROUND IS CONNECTED.

Two chassis ground landings are located on the inside of the DCX chassis (see Figure 14). Refer to mechanical drawing found in Appendix A.3 for greater detail regarding grounding locations. A minimum of #6 AWG chassis ground cable is required. **IMPORTANT:** Grounding hardware not included. A properly-sized grounding conductor must be installed per NEC (250.122).

Table 5. Chassis Ground Specifications

TERMINATION TYPE	HOLE/STUD SIZE	CENTER TO CENTER	RECOMMENDED TORQUE VALUE
Threaded Stud	1/4 in.	5/8 in.	5.83 ft·lbs

Step 1. Select the desired grounding location and break away the associated knock-out points found on the clear plastic covers.

Step 2. Connect the ground cable with 1/4 in. hardware. Ensure heat shrink and no-oxide compound are applied appropriately prior to termination. Torque the fasteners to 5.83 ft·lbs (see Table 5).

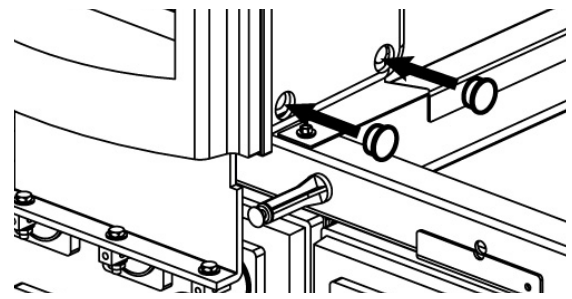

Figure 13. Insert hole plugs

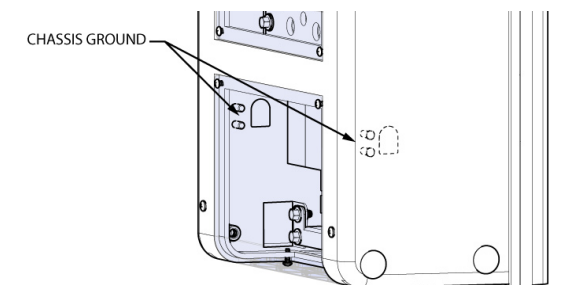

Figure 14. Chassis ground

4.5 Battery Positive Connection

The DCX unit requires battery positive to be connected via a small gauge wire from the battery positive terminal post of the battery string to the battery positive terminal block input on the circuit board located behind the flip-up front panel of the DCX unit.

Step 1. Install a #14 to #16 gauge wire in the “VIN RETURN” terminal position. Connect the other end of this wire to the +48V battery positive connection on the battery string. Route the wire securely away from potential chafe points with metal connections. The DCX unit is shipped with a wire that includes an in-line KLM fuseholder. See Figure 15 for alarm connections.

J7	○	EPO SW	COM
	○	EPO SW	N/O
	○	ALARM	COM
	○	ALARM	NO/NC
	○	Vin	RETURN
J19	○	AUX PWR	+
	○	2A MAX.	-

Figure 15. Connections

4.6 EPO Emergency Power Off Switch Option

The DCX unit is equipped with a terminal block input connection for a remote emergency power off “EPO” switch. External dry contact switch closure is required.



CAUTION!

DO NOT WIRE IN COMMON WITH ANY OTHER ELECTRICAL DEVICE OR APPLY A VOLTAGE ON THIS INPUT FROM ANY OTHER SOURCE OR DAMAGE WILL OCCUR. ONLY CONNECT A DEDICATED EXTERNAL DRY CONTACT CLOSURE NORMALLY OPEN SWITCH TO THIS CIRCUIT.

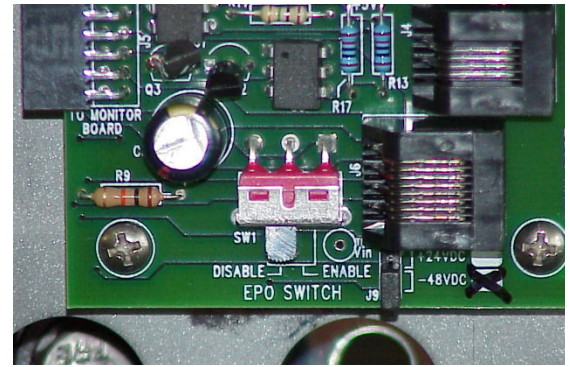

Figure 16. EPO Switch

An external wall mount mushroom head switch is commonly used for EPO functions. Route the two conductors from the switch to the DCX terminal block positions labeled “EPO SW COM” and “EPO SW N/O”. The DCX unit is shipped with the EPO switch function disabled via a slide switch located on the circuit board (see Figure 16). Slide this switch to the “enabled” position if the EPO function is desired.

4.7 Alarm Contacts

The DCX unit comes with an alarm relay with contacts routed to the terminal block on the circuit board assembly. The alarm contacts are rated 0.5A. Remote alarm sensing can be connected to the alarm contacts to provide an alarm when the DCX circuit breaker is off-line or there is an alarm condition. **NOTE:** The DMP digital monitor panel option also uses these alarm contacts to convey other alarm conditions such as over-temperature and other alarm options. Route the alarm wires securely via the cable tie anchor provided below the circuit board assembly.

4.8 Auxiliary Power Port

Auxiliary power is available on the terminal block labeled “AUX PWR.” for powering small 48V nominal loads. This power is diode-ORed from the battery and line and will carry whichever voltage is higher. It is unregulated and protected by the DCX input GMT fuses. 2A is the maximum load supported.

4.9 Electrical Test

Prior to output cable installation, follow these steps:

- Step 1.** Flip the DCX breaker to the OFF position. Ensure that the battery positive wire is installed and routed securely. Ensure that the EPO switch and alarm contact wires are installed if used and routed securely.
- Step 2.** Ensure that the remote EPO switch is in the off position (if used). Connect the battery string cell connection bus bars that were left disconnected for safety purposes during the DCX unit installation. Upon connection of the series string, the “OFF-line” LED will light up.

- Step 3.** Check voltage on the battery termination plate relative to battery positive and ensure that approximately 54 VDC is measured. Ensure there are no cables connected to the DCX output bus bar and that the clear plastic covers are installed.
- Step 4.** Flip DCX breaker to the ON position. The “ON-Line” blue LED should light and the unit should be functional. To test the EPO trip, push in the remote EPO switch; the DCX breaker should trip to the OFF position and the ON-line LED will go out and the OFF-line LED will turn on. The EPO Tripped LED will also turn on and will stay on as long as the remote EPO switch is on.
- Step 5.** Reset the remote EPO switch to off, reset the DCX breaker to ON. Observe correct LED indication of ON-LINE. The alarm contacts can be tested with an ohmmeter if desired by flipping the DCX breaker handle off and on and observing the alarm contacts opening and closing with the ohmmeter.
- Step 6.** Flip DCX breaker to the OFF position.

4.10 Output Connections



CAUTION!

TURN OFF THE DCX BREAKER AND DISCONNECT A SERIES CELL BUS BAR TO DISABLE SERIES STRING CONNECTION AND VOLTAGE TO THE DCX UNIT.



WARNING! ELECTRICAL HAZARD

MULTIPLE POWER SOURCES ARE PRESENT. ENSURE ALL POWER FEEDS ARE NOT ENERGIZED BEFORE INSTALLING THEM. ELECTRICAL INSTALLATION SHOULD ONLY BE PERFORMED BY QUALIFIED PERSONNEL WITH PROPER TOOLS AND PROTECTIVE SAFETY EQUIPMENT. FAILURE TO INSTALL/REINSTALL THE SAFETY COVERS WILL CREATE AN ELECTRICAL HAZARD.



NOTICE:

MAKE SURE THAT ALL FEEDER CABLES HAVE HEAT SHRINK APPLIED PRIOR TO TERMINATION, AND THAT NO-OXIDE COMPOUND IS APPLIED TO ALL COPPER-TO-COPPER CONNECTIONS. SEE SECTION 5 FOR TERMINAL SPECIFICATIONS, TOOLING, AND ORDERING INFORMATION.

Table 6. Output Cable Torque Specifications

TERMINATION TYPE	HOLE/STUD SIZE	CENTER TO CENTER	RECOMMENDED TORQUE VALUE
Threaded Insert	1/2 in.	1.75 in.	43.75 ft·lbs
Threaded Insert	3/8 in.	1 in.	18.75 ft·lbs

- Step 1.** Remove the top clear cover for access to the output cable lug landing bus bar area by removing the four phillips head screws. Four mounting patterns are included for 1/2 in. hardware large pattern lugs such as up to 750MCM, and three 3/8 in. hardware lug patterns are included for smaller lug mounting. Double check with a voltmeter that the input to the DCX is not energized. Ensure no-oxide compound is used on the lug and bus bar surfaces, then secure the output cables and lugs into place. Refer to Table 6 for output cable torque specifications.
- Step 2.** Route the cables vertically to the lacing bar or ladder rack above the unit and lace securely. Ensure that the cable is well supported above the DCX unit to ensure that the cable weight does not place undo strain on the battery terminal or DCX unit.
- Step 3.** Use flush cutters or scissors to cut the appropriate cable access notches in the clear cover to provide clearance for the number of output cables installed. Reinstall the clear cover.

Prior to connection of the battery series cell connections or connection of the output cable ends to rectifier bays or load devices, the user is advised to perform several safety checks and verification of correct wiring polarity and installation.

4.11 Safety Covers



WARNING! ELECTRICAL HAZARD

FAILURE TO REINSTALL THE SAFETY COVERS WILL CREATE AN ELECTRICAL HAZARD.

The DCX unit ships with the plastic safety covers preinstalled. These covers will require removal to allow access to the inside of the unit during cable installation. It is important that all plastic covers have been reinstalled and tightened down with their existing hardware once cable installation is complete.

4.12 Fuse Replacement

- DCX termination board: GMT 2A
- Inline return: KLM 3A

5.0 Product Specifications

Table 7. Technical Specifications

ELECTRICAL	
Voltage	±48VDC, ±24VDC
Input Current	400A, 600A, 800A, 1000A, 1200A
Alarm Contacts	Form-C, 60VDC @ 0.5A max.
Breaker AIC	50kA (800/1000A), 100kA (400/600/1200A)
Shunt Rating	50mV/1200A
CONNECTIONS	
Communications Battery Positive	Terminal block; #14-16 AWG
Output Termination	1/2 in. Threaded insert; 1.75 in. CTC (4 positions) 3/8 in. Threaded insert; 1 in. CTC (3 positions)
Chassis Ground	1/4 in. Threaded stud; 5/8 in. CTC (2 positions)
MECHANICAL	
Dimensions (in.) L x H x D	13.5 x 15 x 10
Weight	22 lbs.
ENVIRONMENTAL	
Operating Temperature	50°C Operating
Humidity	0 to 95% RH Non-Condensing
Elevation	-500 to 2800m

Table 8. Agency Certifications

UL	
UL File Number	E473904
UL Standard	ANSI/UL 60950-1

6.0 Models and Accessories

NOTE: For latest part numbers and compatibility, please refer to DCX ordering guide (Doc. #C048-014-01).
Mounting kit designs are based on the latest available battery stack information provided by the battery manufacturers.

Table 9. DCX Model Configurations - Switch Only Versions (No Current Limiting)

DESCRIPTION	PART NUMBER
400A DCX Battery Disconnect, -48VDC, w/shunt	C016-1001-10
600A DCX Battery Disconnect, -48VDC, w/shunt	C016-1003-10
800A DCX Battery Disconnect, -48VDC, w/shunt	C016-1005-10
1000A DCX Battery Disconnect, -48VDC, w/shunt	C016-1007-10
1200A DCX Battery Disconnect, -48VDC, w/shunt	C016-1009-10

Table 10. DCX Model Configurations - Magnetic Trip Versions

DESCRIPTION	PART NUMBER
400A DCX Battery Disconnect, -48VDC, w/shunt	C016-198-10
600A DCX Battery Disconnect, -48VDC, w/shunt	C016-195-10
800A DCX Battery Disconnect, -48VDC, w/shunt	C016-199-10
1000A DCX Battery Disconnect, -48VDC, w/shunt	C016-196-10
1200A DCX Battery Disconnect, -48VDC, w/shunt	C016-207-10

Table 11. Battery Mounting Bracket Kits - For EnerSys® Batteries

DESCRIPTION	APPLICABLE BATTERY SYSTEM	3X8 CONFIG.	4X6 CONFIG.	PART NUMBER
DCX Mount Kit, EnerSys DDmP50-17, 3X8	DDmP50-17	•		C016-2314-10
DCX Mount Kit, EnerSys DDmP50-17, 4X6	DDmP50-17		•	C016-2300-10
DCX Mount Kit, EnerSys DDmP85-15, 4x6	DDmP85-15		•	C016-2320-10
DCX Mount Kit, EnerSys DDmP85-21, 3X8	DDmP85-21	•		C016-2315-10
DCX Mount Kit, EnerSys DDmP85-21, 4X6	DDmP85-21		•	C016-2301-10
DCX Mount Kit, EnerSys DDmP100-21, 3X8	DDmP100-21	•		C016-2311-10
DCX Mount Kit, EnerSys DDmP100-21, 4X6	DDmP100-21		•	C016-2312-10
DCX Mount Kit, EnerSys DDmP100-25, 3X8	DDmP100-25	•		C016-2316-10
DCX Mount Kit, EnerSys DDmP100-25, 4X6	DDmP100-25		•	C016-2302-10
DCX Mount Kit, EnerSys DDmP100-33, 3X8, 4X6	DDmP100-33	•	•	C016-2317-10
DCX Mount Kit, EnerSys DDmP125-25, 3X8	DDmP125-25	•		C016-2322-10
DCX Mount Kit, EnerSys DDmP125-25, 4X8	DDmP125-25		•	C016-2323-10
DCX Mount Kit, EnerSys DDmP125-33, 3X8, 4X6	DDmP125-33	•	•	C016-2318-10
DCX Mount Kit, EnerSys mP50-17, 3X8	mP50-17	•		C016-2303-10
DCX Mount Kit, EnerSys mP50-17, 4X6	mP50-17		•	C016-2304-10
DCX Mount Kit, EnerSys mP85-15, 4X6	mP85-15		•	C016-2321-10
DCX Mount Kit, EnerSys mP85-21, 3X8	mP85-21	•		C016-2305-10
DCX Mount Kit, EnerSys mP85-21, 4X6	mP85-21		•	C016-2306-10
DCX Mount Kit, EnerSys mP100-25, 3X8	mP100-25	•		C016-2307-10
DCX Mount Kit, EnerSys mP100-25, 4X6	mP100-25		•	C016-2308-10
DCX Mount Kit, EnerSys mP100-33, 3X8, 4X6	mP100-33	•	•	C016-2309-10
DCX Mount Kit, EnerSys mP125-25, 3X8	mP125-25	•		C016-2310-10
DCX Mount Kit, EnerSys mP125-25, 4X6	mP125-25		•	C016-2313-10
DCX Mount Kit, EnerSys mP125-33, 3X8, 4X6	mP125-33	•	•	C016-2319-10

Table 12. Battery Mounting Bracket Kits - For C&D Technologies® Batteries

DESCRIPTION	APPLICABLE BATTERY SYSTEM	PART NUMBER
DCX Mount Kit, C&D MSE AT35	AT-27, AT-35	C016-372-10
DCX Mount Kit, C&D AT07 to AT23	AT-07, AT-09, AT-11, AT-15, AT-19, AT-23	C016-371-10
DCX Mount Kit, C&D AT-27	AT-27	C016-732-10
DCX Mount Kit, C&D AT-27P to AT-39P	AT-35P, AT-39P	C016-1017-10
DCX Mount Kit, C&D MSE1440	MSE-1440	C016-246-10

Table 13. Battery Mounting Bracket Kits - For GNB® Batteries

DESCRIPTION	APPLICABLE BATTERY SYSTEM	PART NUMBER
DCX Mount Kit, GNB 90A5 to 13	90A05, 90A07, 90A09, 90A11, 90A13	C016-231-10
DCX Mount Kit, GNB 100A29 to 33	100A29, 100A31, 100A33	C016-225-10
DCX Mount Kit, GNB90A13	100A17, 100A19, 100A21, 100A23, 100A25, 100A27	C016-228-10

Table 14. Battery Mounting Bracket Kits - For East Penn Manufacturing Batteries - Interlocking

DESCRIPTION	APPLICABLE BATTERY SYSTEM	PART NUMBER
DCX Mount Kit, Unigy 95-17 to 95-27, Interlocking	95-17, 95-19, 95-21, 95-23, 95-25, 95-27	C016-252-10
DCX Mount Kit, Unigy 95-29 to 95-33, Interlocking	95-29, 95-31, 95-33	C016-210-10
DCX Mount Kit, Unigy 125-33, Interlocking	125-33	C016-374-10
DCX Mount Kit, Unigy 6AVR125-33, Interlocking	6AVR125-33 NEBS; 3x8	C016-1658-10

Table 15. Battery Mounting Bracket Kits - For East Penn Manufacturing Batteries - Non-Interlocking

DESCRIPTION	APPLICABLE BATTERY SYSTEM	PART NUMBER
DCX Mount Kit, 95-17 to 95-27, Non-Interlocking	95-17, 95-19, 95-21, 95-23, 95-25, 95-27	C016-250-10
DCX Mount Kit, 95-29 to 95-33, Non-Interlocking	95-29, 95-31, 95-33	C016-214-10

Table 16. Model Accessories

DESCRIPTION	PART NUMBER
EPO Switch, Wall Plate Assembly	C016-211-10
TRD Thermal Runaway Detector Kit	C016-934-10

Appendix A: Mechanical Drawings

A.1 DCX Battery Disconnect Isometric View

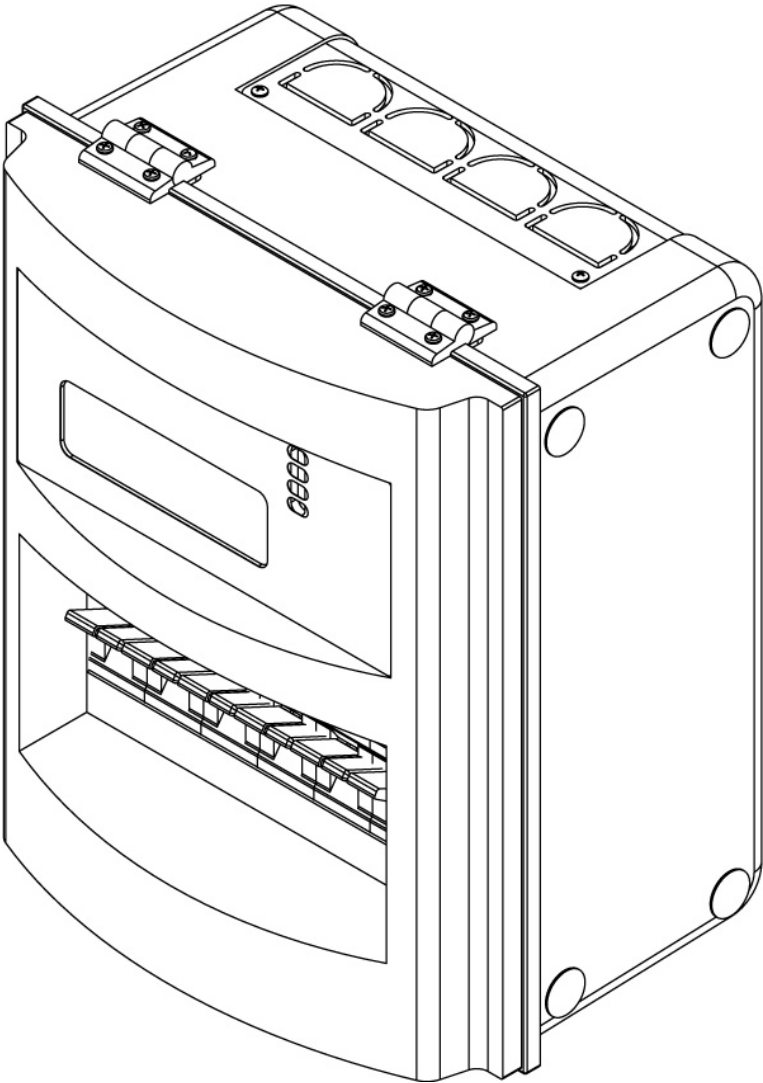

A.2 DCX Battery Disconnect Dimensions

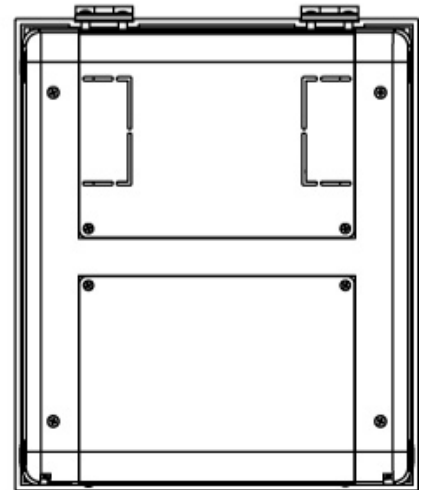
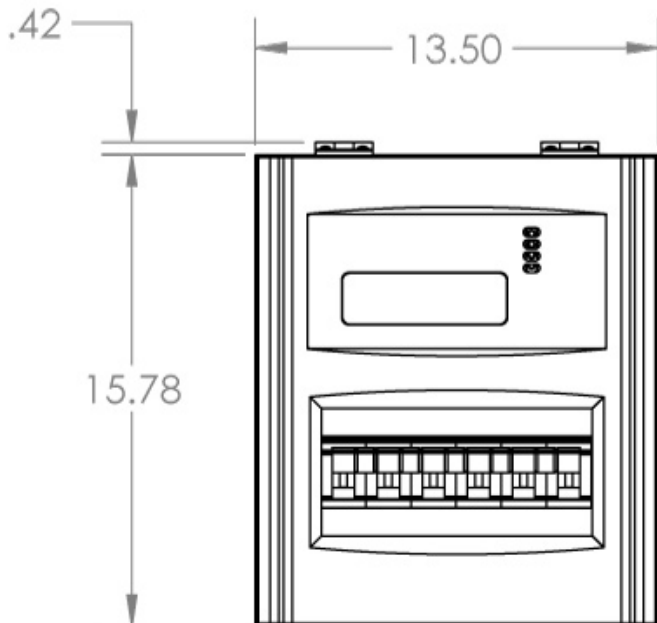
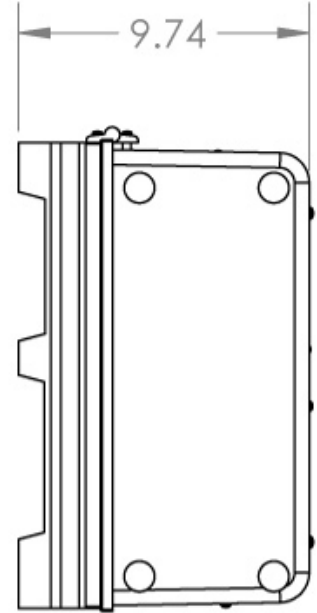
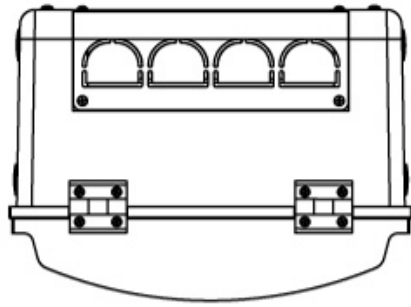

A.3 DCX Chassis Ground Locations

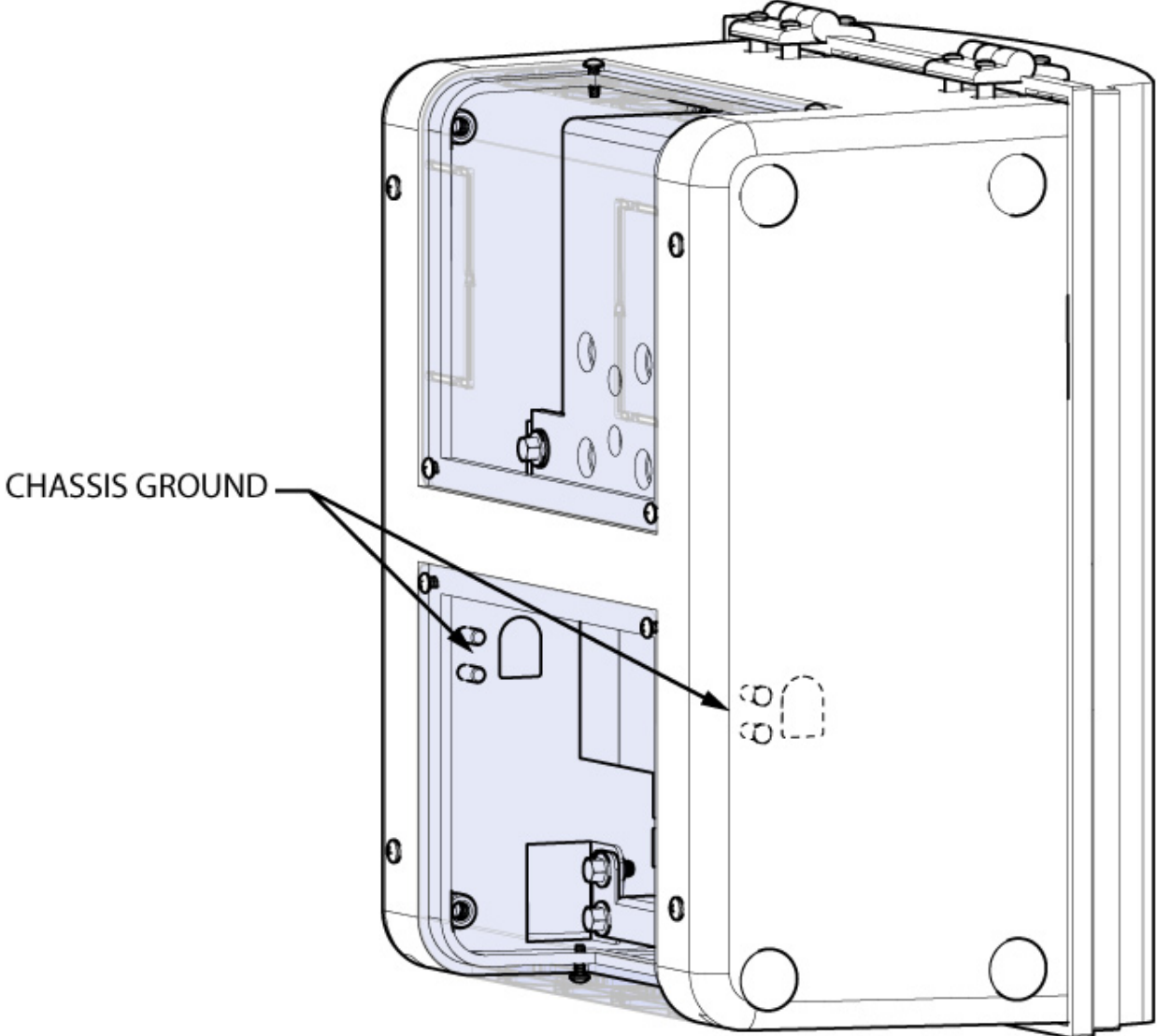



an EnerSys company



an EnerSys® company

Alpha Technologies Services, Inc. | 3767 Alpha Way, Bellingham, WA 98226, USA

Tel.: Toll Free North America: +1 800 322 5742 | Outside US: +1 360 647 2360 | Technical Support: +1 800 863 3364

For more information visit our website at: www.alpha.com

© 2021 Alpha Technologies Services, Inc. All Rights Reserved. Trademarks and logos are the property of Alpha Technologies Services, Inc. and its affiliates unless otherwise noted. Subject to revisions without prior notice. E.&O.E.

C048-699-30 R03, Rev. B (01/2021)