



Intelligent CableUPS® Technical Manual

XM3-HP Series
Effective: June 2018



Safety Notes

Review the drawings and illustrations contained in this document before proceeding. If there are any questions regarding the safe installation or operation of the system, contact Alpha Technologies or the nearest Alpha representative. Save this document for future reference.

To reduce the risk of injury or death and to ensure the continued safe operation of this product, the following symbols have been placed throughout this manual. Where these symbols appear, use extra care and attention.



WARNING! GENERAL HAZARD

GENERAL HAZARD WARNING provides safety information to PREVENT INJURY OR DEATH to the technician or user.



WARNING! ELECTRICAL HAZARD

ELECTRICAL HAZARD WARNING provides electrical safety information to PREVENT INJURY OR DEATH to the technician or user.



WARNING! FUMES HAZARD

FUMES HAZARD WARNING provides fumes safety information to PREVENT INJURY OR DEATH to the technician or user.



WARNING! FIRE HAZARD

FIRE HAZARD WARNING provides flammability safety information to PREVENT INJURY OR DEATH to the technician or user.

There may be multiple warnings associated with the call out. Example:



WARNING! ELECTRICAL & FIRE HAZARD

This WARNING provides safety information for both Electrical AND Fire Hazards



CAUTION!

CAUTION provides safety information intended to PREVENT DAMAGE to material or equipment.



NOTICE:

NOTICE provides additional information to help complete a specific task or procedure.

ATTENTION:

ATTENTION provides specific regulatory/code requirements that may affect the placement of equipment and /or installation procedures.

The following sections contain important safety information that must be followed during the installation and maintenance of the equipment and batteries. Read all of the instructions before installing or operating the equipment, and save this manual for future reference.

XM3-HP CableUPS®

Technical Manual

017-882-B0-001, Rev. E

Effective Date: June 2018

© 2018 by Alpha Technologies, Inc.

Disclaimer

Images contained in this manual are for illustrative purposes only. These images may not match your installation.

Operator is cautioned to review the drawings and illustrations contained in this manual before proceeding. If there are questions regarding the safe operation of this powering system, please contact Alpha Technologies or your nearest Alpha representative.

Alpha shall not be held liable for any damage or injury involving its enclosures, power supplies, generators, batteries or other hardware if used or operated in any manner or subject to any condition not consistent with its intended purpose or is installed or operated in an unapproved manner or improperly maintained.

Notice of FCC Compliance

Per FCC 47 CFR 15.21:

Changes or modifications not expressly approved by the party responsible for compliance could void the user's authority to operate the equipment.

Per FCC 47 CFR 15.105:

This equipment has been tested and found to comply with the limits for a Class A digital device, pursuant to part 15 of the FCC Rules. These limits are designed to provide reasonable protection against harmful interference when the equipment is operated in a commercial environment. This equipment generates, uses and can radiate radio frequency energy and, if not installed and used in accordance with the instruction manual, may cause harmful interference to radio communications. Operation of this equipment in a residential area is likely to cause harmful interference in which case the user will be required to correct the interference at their own expense.

Contact Information

Sales information and customer service in USA

(7AM to 5PM, Pacific Time):

1 800 322 5742

Complete technical support in USA

(7AM to 5PM, Pacific Time or 24/7 emergency support):

1 800 863 3364

Sales information and technical support in Canada:

1 888 462 7487

Website:

www.alpha.com

Table of Contents

1.0 Introduction	16
1.1 Alpha XM3-HP Intelligent CableUPS®	16
1.2 Theory of Operation	17
1.2.1 AC (Line) Operation	17
1.2.2 Standby Operation	17
1.2.3 Charger Modes of Operation	18
1.2.4 Output Voltage Modes of Operation	23
1.3 Alpha XM3-HP CableUPS® Layout	24
1.3.1 Side Panel Connectors	24
1.3.2 Front Panel Indicators	25
1.3.3 AlphaDOC (Dual Output Controller)	26
1.3.4 Smart AlphaGuard	29
1.3.5 Inverter Module Overview	36
1.3.6 Optional DOCSIS Status Monitoring Transponders	37
2.0 Installation	39
2.1 Installation Procedure	39
2.1.1 Pre-installation Inspection	39
2.1.2 Internal Security Screw Kit Installation	39
2.2 XM3-HP Start-Up Procedure	41
2.2.1 Parts and Connections	41
2.2.2 Battery Installation Options and Wiring Diagram	42
2.2.3 120/240V Configuration Procedure	48
2.2.4 63/89VAC Output Voltage Reconfiguration Procedure	49
2.2.5 Optional Smart AlphaGuard and Alpha APPS Installation	50
2.2.6 Optional N+1 Configurations	51
2.2.7 Communications DOCSIS Status Monitoring	53
2.2.8 Power Module Configuration and Installation Procedure	55
2.2.9 Local Verification of DOCSIS Transponder	58
2.2.10 Web Interface	59
2.2.11 Remote Web Server Access	62
2.2.12 Navigating the Web Page	63
2.2.13 Web Interface Security Levels	64
2.2.14 Verifying Communication Parameters	65
2.2.15 Verifying Power Supply and Battery Parameters	66
2.2.16 Remote Self Tests via the Web Page	66
3.0 Operation	67
3.1 Start-Up and Test	67
3.1.1 Self Test Operation	67
3.2 Using the Smart Display	68
3.3 Smart Display Menus	69
3.3.1 Power Information and Configuration	70
3.3.2 Battery Information and Configuration	71
3.3.3 Configuring XM3-HP for XTV 18V4 Batteries	72
3.3.4 Communication Information and Configuration	73
3.3.5 Alpha Applications Information and Configuration	76
3.4 AlphaAPPs Overview	77
3.4.1 Display Structure	77
3.4.2 Applications	79

Table of Contents

- 3.5 Active Alarms 88
 - 3.5.1 Menu Structure/Navigation (from Active Alarms Screen) 89
 - 3.5.2 PWR Alarms 90
 - 3.5.3 BATT Alarms 91
 - 3.5.4 COMM Alarms 92
 - 3.5.5 APP Alarms 92
- 3.6 Smart Display Glossary. 92
- 3.7 Automatic Performance Test 96
- 3.8 Providing Power via Portable Generator or Inverter 97
 - 3.8.1 DC Powering 97
 - 3.8.2 AC Powering 97
 - 3.8.3 Using a Truck-mounted Inverter or Generator 98
- 3.9 Resumption of Utility Power 99
- 4.0 Maintenance 100
 - 4.1 Safety Precautions 100
 - 4.2 Required Tools and Equipment. 100
 - 4.3 Power Supply System Maintenance 101
 - 4.3.1 Preparing for Maintenance 101
 - 4.3.2 Periodic Maintenance Tasks 101
 - 4.3.3 MOV Board Replacement. 104
 - 4.4 PM Certification Report. 105
- 5.0 Shut Down 107
 - 5.1 Emergency Shutdown Procedure: 107
- 6.0 Specifications 108
 - 6.1 Specifications (Alpha XM3-HP CableUPS North American Models) 108
 - 6.2 Specifications (Alpha XM3-HP CableUPS International Models). 109
 - 6.3 Safety and EMC Compliance. 110
 - 6.4 Simplified Block Diagram 111
 - 6.5 System Options. 112
 - 6.6 Return and Repair Information 112

Figures

Typical 120VAC Service Entrance Wiring	12
Typical 120 VAC 20A Receptacle Wiring, 5-20R (P/N 531-006-19)	12
Typical 240 VAC 15A Receptacle Wiring, 6-15R (P/N 531-004-19)	12
Typical 240 VAC 20A Receptacle Wiring, 6-20R (P/N 531-008-19)	12
Typical 240VAC 60 Hz Service Entrance Wiring	13
Typical 230VAC 50 Hz Service Entrance Wiring	13
SPI Location	14
Communications Grounding	15
Fig. 1-1, Alpha XM3-HP Intelligent CableUPS	16
Fig. 1-2, 3-Stage Charger Modes	19
Fig. 1-3, 4-Stage Charger Modes	20
Fig. 1-4, 4-Stage Charger Modes for XTV Batteries	21
Fig. 1-5, 5-Stage Charger Modes	22
Fig. 1-6, Front Panel, XM3-HP Power Supply	24
Fig. 1-7, Side Panel, XM3-HP Power Supply	24
Fig. 1-8, Detail View, Front Panel Connections and Indicators	25
Fig. 1-9, Output Voltage Terminal Block	27
Fig. 1-10, AlphaDOC Standoff and Screw Locations.	27
Fig. 1-11, 5-Position Output Voltage Terminal Block	28
Fig. 1-12, Single Battery String Wiring Diagram (w/ embedded SAG Harness depicted)	30
Fig. 1-13, Dual Battery String Wiring Diagram (w/ embedded SAG Harness depicted)	31
Fig. 1-14, Multiple Battery String Wiring Diagram (w/ embedded SAG Harness depicted)	32
Fig. 1-15, SAG Front Panel	34
Fig. 1-16, Inverter Module Connections	36
Fig. 1-17, AlphaNet Series Transponders	38
Fig. 2-1, Required Materials	40
Fig. 2-2, Security Screw Mounting Location	40
Fig. 2-3, Power Supply/Enclosure Shelf Security Screw Stack Up	40
Fig. 2-4, Installation of XM3-HP	41
Fig. 2-5, Placement of Battery Spacer Clips (for domestic and international 36V battery strings).	42
Fig. 2-6, Battery Wiring Diagram (w/ embedded SAG option depicted)	42
Fig. 2-7, Precision Temperature Sensor (PTS), p/n 746-331-20	42
Fig. 2-8, AlphaCell 18v4 Two Battery Configuration (36V, 55Ah)	43
Fig. 2-9, AlphaCell 18v4 Four Battery Configuration (36V, 110Ah Capacity)	44
Fig. 2-10, Wiring diagram, 8-battery Parallel Configuration	45
Fig. 2-11, Battery Sense Wiring, 36V, 2 Battery Configuration.	46
Fig. 2-12, Battery Sense Wiring, 36V, 4 Battery Configuration.	46
Fig. 2-13, Battery Sense Wiring, 36V, 2 Battery Configuration.	47
Fig. 2-14, Battery Sense Wiring, 36V, 4 Battery Configuration.	47
Fig. 2-15, Battery Terminal Bolt Stack-up	48
Fig. 2-16, Fuse Bolt Stack-up	48
Fig. 2-17, Transformer Harness	48
Fig. 2-18, 120/240V Connector	48
Fig. 2-19, Line Cord Plugs	49
Fig. 2-20, Input Voltage Setting Screen	49
Fig. 2-21, Voltage Terminal Location behind Inverter Module	49
Fig. 2-22, Voltage Wire Position	49
Fig. 2-23, Front Panel Fastener Locations.	50

Figures

Fig. 2-24, APPS Card Standoff, Screw and Ribbon Cable Locations	50
Fig. 2-25, SAG Card Standoffs, Screws and Ribbon Cable Locations.	50
Fig. 2-26, SPI, AlphaDOC and SAG Harness Connections	51
Fig. 2-27, N+1 Configuration	51
Fig. 2-28, Dual Redundancy N+1 Configuration	52
Fig. 2-29, Active Alarm Screen	52
Fig. 2-30, N+1 In Use Alarm Screen	52
Fig. 2-31, DOCSIS Status Monitor Front Panel Connections	53
Fig. 2-32, Active Alarm Table	56
Fig. 2-33, Enter Battery Date Code	56
Fig. 2-34, Enter Battery MHOs Reading	56
Fig. 2-35, Select Language in PWR CNFG Menu	57
Fig. 2-36, COMM Menu Options	58
Fig. 2-37, DM3/DSM3/IDH4 Series Web Page.	59
Fig. 2-38, Local Area Connection Properties Screen, Windows 7	60
Fig. 2-39, Internet Protocol (TCP/IP) Properties Screen, Windows 7	60
Fig. 2-40, Local Area Connection Properties Screen, Windows 10	61
Fig. 2-41, Internet Protocol (TCP/IP) Properties Screen, Windows 10.	61
Fig. 2-42, Web Server Home Page	62
Fig. 2-43, DSM3/IDH4 Series Navigation Bar Items	63
Fig. 2-44, Communication Parameters.	65
Fig. 2-45, Advanced Communication Parameters	65
Fig. 2-46, Power Supply and Battery Parameters	66
Fig. 2-47, Location of "Start" Button for Self Test	66
Fig. 3-1, Operation Normal Display Screen	68
Fig. 3-2, Navigating Through Menu Screens.	68
Fig. 3-3, Input Voltage Settings Screen	69
Fig. 3-4, Active Alarm Table	88
Fig. 3-5, Sample Active Alarm Display, PWR Menu	89
Fig. 3-6, Sample Active Alarm Display, BATT Menu	89
Fig. 3-7, Sample Active Alarm Display, COMM Menu	89
Fig. 4-1, XM3-HP System Components	102
Fig. 4-2, Removing the Inverter	104
Fig. 4-3, Capacitor Removed from Mounting Bracket and MOV Board Location	104
Fig. 4-4, MOV Board Model	104
Fig. 4-5, PM Certification Report, Page 1	105
Fig. 4-6, PM Certification Report, Page 2	106
Fig. 5-1, Emergency Shutdown	107
Fig. A-1, Block Diagram	111

Tables

Circuit Breakers and Service Disconnects	11
Table 1-1, Low Battery Cutoff (EOD).	18
Table 1-2, Charger Modes of Operation	18
Table 1-3, Duration of Load	26
Table 1-4, Smart AlphaGuard LED Alarm States.	34
Table 1-5, Comparative Features, AlphaNet Series Communication Modules.	37
Table 2-1, DSM3 / IDH4 LEDs Behavior	54
Table 2-2, DM3.0 LEDs Behavior	54
Table 2-3, DSM3/IDH4 Series Transponder Security Levels.	64
Table 3-1, AC Output	67
Table 3-2, Main Menu Functions	68
Table 3-3, OTHER Battery Values	72
Table 3-4, Logged Events and Alarms	80
Table 3-5, PWR Alarms: Classifications, Causes and Corrections.	90
Table 3-6, BATT Alarms: Classifications, Causes and Corrections	91
Table 3-7, COMM Alarms: Classifications, Causes and Corrections.	92
Table 3-8, APP Alarms: Classifications, Causes and Corrections	92
Table A-1, North American Specifications	108
Table A-2, International Specifications	109
Table A-3, Product Certifications Regarding Safety, EMC Compliance	110

XM3-HP Safety & Compliance Notes

Review the drawings and illustrations contained in this manual before proceeding. If there are any questions regarding the safe installation or operation of the system, contact Alpha Technologies or the nearest Alpha representative. Save this document for future reference.

To reduce the risk of injury or death and to ensure the continued safe operation of this product, the following symbols have been placed throughout this manual. Where these symbols appear, use extra care and attention.

Safety Precautions



WARNING! ELECTRICAL & FIRE HAZARD

Do not allow live battery wires to contact the enclosure chassis. Shorting battery wires can result in a fire or possible explosion.



WARNING! ELECTRICAL HAZARD

- In the event of a short-circuit, batteries present a risk of electrical shock and burns from high current. Observe proper safety precautions.
- The battery string, which provides backup power, contains dangerous voltages. Only qualified personnel should inspect or replace batteries.
- The power supply contains more than one live circuit! Even though AC voltage is not present at the input, voltage may still be present at the output.



CAUTION!

- Only qualified personnel should service the power supply.
- Verify the voltage requirements of the equipment to be protected (load), the AC input voltage to the power supply (line) and the output voltage of the system prior to installation.
- Equip the utility service panel with a properly rated circuit breaker for use with this power supply.
- When connecting the load, DO NOT exceed the output rating of the power supply.
- Always use proper lifting techniques whenever handling units, modules or batteries.

ATTENTION:

This power supply has been investigated by regulatory authorities for use in various Alpha enclosures. If you are using a non-Alpha enclosure, it is your responsibility to ensure your combination conforms to your local regulatory requirements and the power supply remains within its environmental specifications.

Battery Safety Notes



WARNING! ELECTRICAL HAZARD

- Always wear eye protection, rubber gloves, and a protective vest when working near batteries. To avoid battery contact, remove all metallic objects, (such as rings or watches), from your person.
- Prior to handling the batteries, touch a grounded metal object to dissipate any static charge that may have developed on your body.
- Use tools with insulated handles, do not rest any tools on top of batteries.
- Use special caution when connecting or adjusting battery cabling. An improperly or unconnected battery cable can make contact with an unintended surface that can result in arcing, fire, or a possible explosion.



WARNING! FIRE HAZARD

- Batteries produce explosive gases. Keep all open flames and sparks away from batteries.
- Do not charge batteries in a sealed container. Each battery should have at least 1/2 inch (13 mm) of space between it and all surrounding surfaces to allow for convection cooling.
- All battery compartments must have adequate ventilation to prevent an accumulation of potentially dangerous gas. Never place batteries in a sealed enclosure. Ensure all enclosure vents and filters are clean and free of debris.



WARNING! GENERAL HAZARD

- Any gelled or liquid emissions from a valve-regulated lead-acid (VRLA) battery contains diluted sulfuric acid, which is harmful to the skin and eyes. Emissions are electrolytic and are electrically conductive and corrosive.
- If any battery emission contacts the skin, wash immediately and thoroughly with water. Follow your company's approved chemical exposure procedures.
- Neutralize any spilled battery emission with the special solution contained in an approved spill kit or with a solution of one pound bicarbonate of soda to one gallon of water. Report a chemical spill using your company's spill reporting structure and seek medical attention if necessary.

Battery Maintenance Guidelines



CAUTION!

- Inspect each battery during every maintenance check. Replace or repair batteries if any of the following is found:
 - **Signs of battery cracking, leaking or swelling.**
 - **Signs of battery cable damage.**
 - **Loose battery connection hardware.**
- Do not attempt to remove the vents (valves) from the AlphaCell broadband battery or add water. This is a safety hazard and voids the warranty.
- A battery showing signs of cracking, leaking, or swelling should be replaced immediately by authorized personnel.
- Always replace batteries with those of an identical type and rating. Match conductance, voltage and date codes. Never install untested batteries.
- Always follow battery manufacturer's storage instructions.
- Apply NO-OX grease on all exposed connections.

ATTENTION:

- Clean up any spilled electrolyte in accordance with all federal, state, and local regulations or codes.
- Spent or damaged batteries are environmentally unsafe. Always recycle used batteries. Refer to local codes for proper disposal of batteries.

Utility Power Connection Notes

 **NOTICE:**

Alpha enclosures are engineered to properly vent the power supply. The power supplies have been investigated by regulatory authorities for use in various Alpha enclosures. If you are using a non-Alpha enclosure, it is your responsibility to ensure your combination conforms to your local regulatory requirements and the power supply remains within its environmental specifications.

ATTENTION:

Connecting to the utility should be performed only by qualified service personnel and in compliance with local electrical codes. Connection to utility power must be approved by the local utility before installing the power supply.

Local regulatory authorities may require the use of an approved service entrance and/or service disconnect switch when the power supply is installed in an outdoor enclosure. Alpha enclosures have switch options. The installer may need to provide these if using a non-Alpha enclosure.

 **NOTICE:**

In order to accommodate the high-inrush currents normally associated with the start-up of ferroresonant transformers (400 Amp, no-trip, first-half cycle), either a “high-magnetic” or an HACR (Heating, Air Conditioning, Refrigeration) trip breaker must be used. Do not replace these breakers with a conventional service entrance breaker. Alpha recommends ONLY Square D breakers because of the increased reliability required in this powering application. High-magnetic Square D circuit breakers and a BBX option (UL Listed service entrance) are available from Alpha Technologies.

Description	Alpha Part Number	Square D Part Number
240V Installation - HACR (15A)	470-224-10	QO215
120V Installation - High-magnetic (20A)	470-017-10	QO120HM
BBX - External Service Disconnect	020-085-10	QO2 -4L70RB
BBX - External Service Disconnect	020-141-10	QO8-16L100RB

Circuit Breakers and Service Disconnects

ATTENTION:

In most cases, the following configurations qualify for service entrance use when wiring a duplex receptacle to a service disconnect. Other codes may also apply. Always contact your local utility to verify the wiring conforms to applicable codes.

XM3-HP Connections

Proper 120VAC 20A service requires the installation site be:

- Equipped with a 120VAC duplex receptacle which provides power to the power supply and peripheral equipment.
- Have a NEMA 5-20R receptacle protected by a single-pole, 20 Amp High Magnetic (HM) circuit breaker inside the service entrance.
- Checked to NEC/CEC Code or with your local regulatory authority to verify proper wire AWG (suggested wire gauge is 12AWG).
- Equipped with a grounding clamp on the enclosure to facilitate dedicated grounding.

 **NOTICE:**

When it is required to bond the box to a neutral plate, use the long green bonding screw provided (Alpha P/N 523-011-10, Square D P/N 40283-371-50).

Utility Power Connection Notes, continued

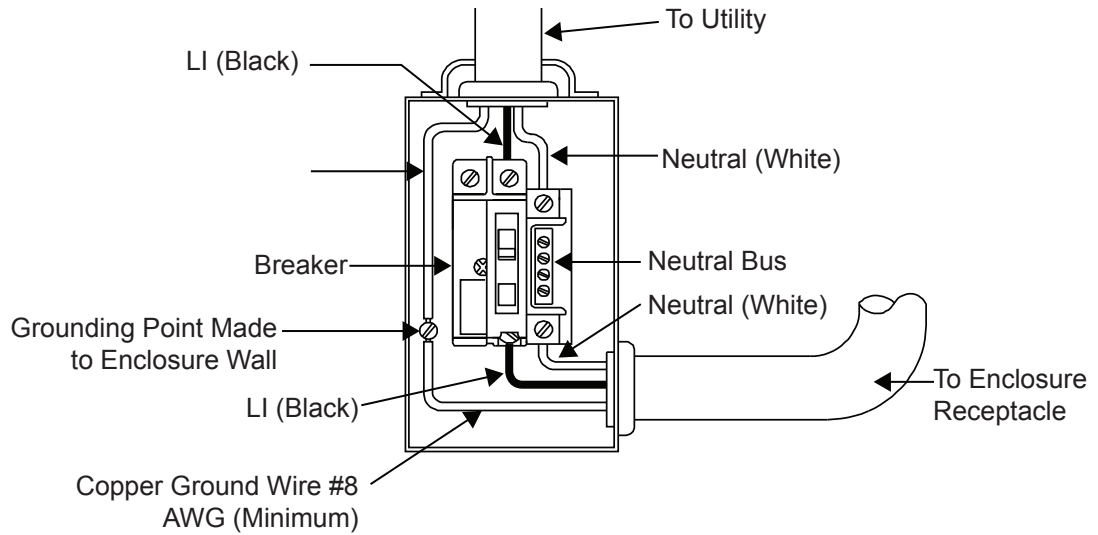

Typical 120VAC Service Entrance Wiring

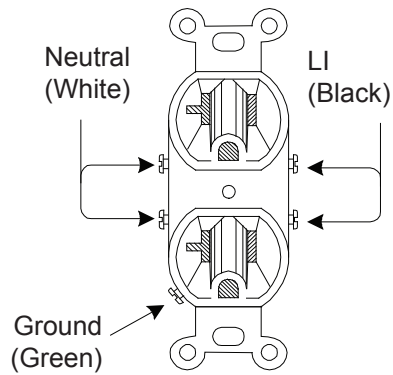

Typical 120 VAC 20A Receptacle Wiring, 5-20R (P/N 531-006-19)

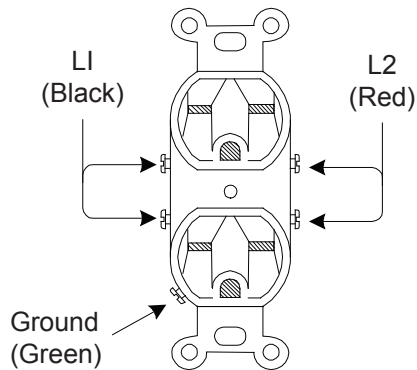

Typical 240 VAC 15A Receptacle Wiring,
6-15R (P/N 531-004-19)

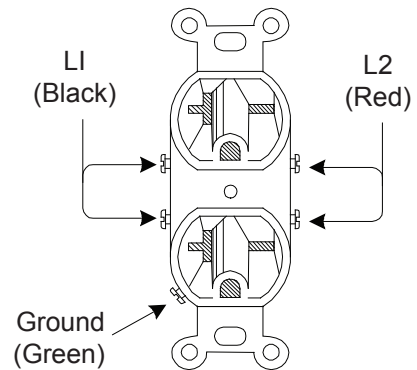

Typical 240 VAC 20A Receptacle Wiring,
6-20R (P/N 531-008-19)

Utility Power Connection Notes, continued

Proper 240VAC 15A service requires the installation site be:

- Equipped with a 240VAC duplex receptacle to provide power to the power supply and peripheral equipment.
- Have a NEMA 6-15R receptacle that is protected by a single, 2-pole, common trip 15A circuit breaker inside the service entrance.
- Checked to NEC/CEC Code or with your local regulatory authority to verify proper wire AWG (suggested wire gauge is 14AWG).
- Equipped with a grounding clamp on the enclosure to facilitate dedicated grounding.

✓ **NOTICE:**

When it is required to bond the box to a neutral plate, use the long green bonding screw provided (Alpha P/N 523-011-10, Square D P/N 40283-371-50).

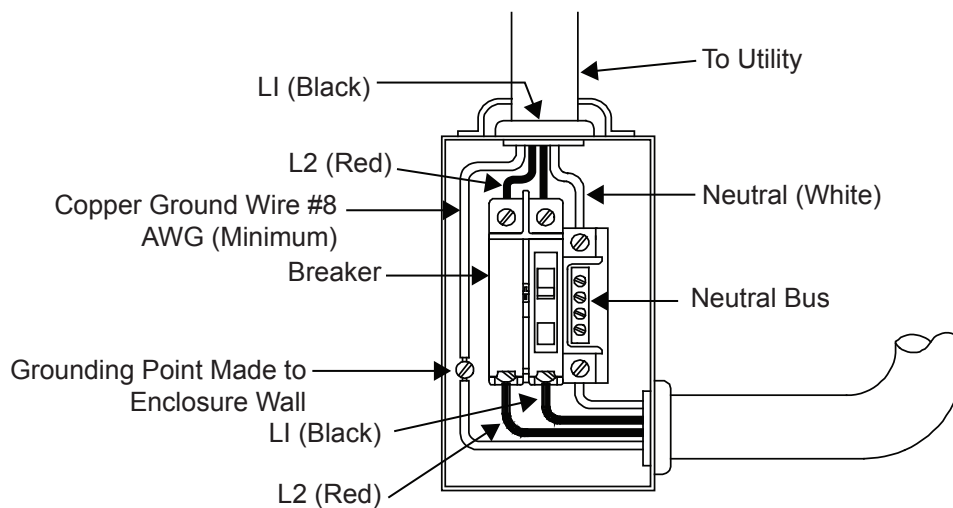

Typical 240VAC 60 Hz Service Entrance Wiring

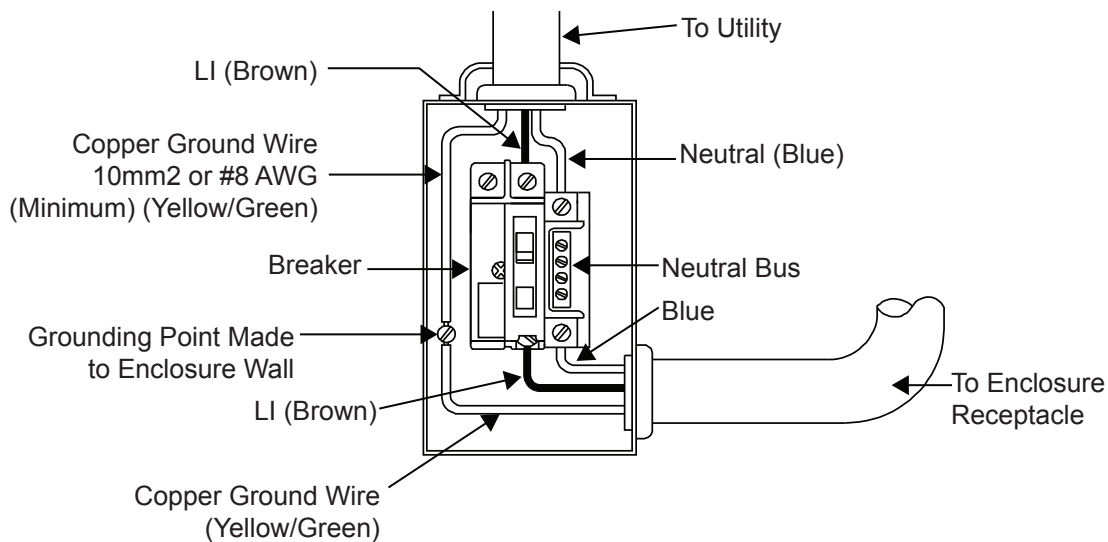

Typical 230VAC 50 Hz Service Entrance Wiring

Grounding & Earth Connection Notes

In order to provide a ready, reliable source of backup power, it is necessary to connect the power supply to an effective grounding and Earthing system. This not only provides for the safety of the service personnel responsible for its operation and maintenance, but also facilitates the proper operation and protection of the equipment within the network. Such a grounding system provides protection with respect to operator safety, system communication and equipment protection.

Lightning strikes, grid switching or other aberrations on the power line and/or communications cable have the potential to cause high-energy transients that can damage the powering or communications systems. The most viable method available to protect the system from damage is to divert these unwanted high-energy transients along a low-impedance path to earth. A low-impedance path to earth prevents these currents from reaching high voltage levels and posing a threat to equipment.

The key to the success of lightning protection is single-point grounding so the components of the grounding system appear as a single point of uniform impedance. Two places recommended by Alpha for single-point grounding are connections in the enclosure and connections to earth. Single-point grounding in the enclosure is achieved by bonding all electrical connections to the enclosure, including the connection to earth, as close together on the enclosure as possible. Single-point grounding for the connection to earth is achieved, for example by the proper bonding of the ground rods.

Safety Ground & Earth Connection

The safety ground and earth is a two-part system, comprised of the utility service and the Alpha system.

1. The utility service;

As a minimum requirement for the protection of Alpha equipment, the local utility service must provide a low-impedance path for fault current return. In addition, there must be a low impedance bonded path between the power supply ground pin and the enclosure.

2. The Alpha grounding system;

The Alpha grounding system consists of a low-impedance connection between the enclosure and an Earth Ground (located at least 6' away from the Utility Earth connection).

This impedance between the enclosure and Earth must be 25 Ohms or less at 60 Hertz as measured by AMPROBE Model DGC-1000 or equivalent. The measurement should be made on the wire or ground rod after it exits the enclosure.

Local soil conditions will determine the complexity of the grounding system required to meet the 25 Ohm (maximum) resistance specified above. For example, a single 8' ground rod may be sufficient to meet the requirement. In some cases, a more elaborate system may be required such as multiple ground rods connected by a #6 AWG solid copper cable buried 8-12" below the surface. Where this is not possible, contact a local grounding system expert for alternate methods that will meet the 25 Ohm (maximum) specification.

All ground rod connections must be made by means of a listed grounding clamp suitable for direct burial or exothermic welding.

Power Output Return

For proper operation, the Service Power Inserter (SPI) must be securely bonded to the enclosure.

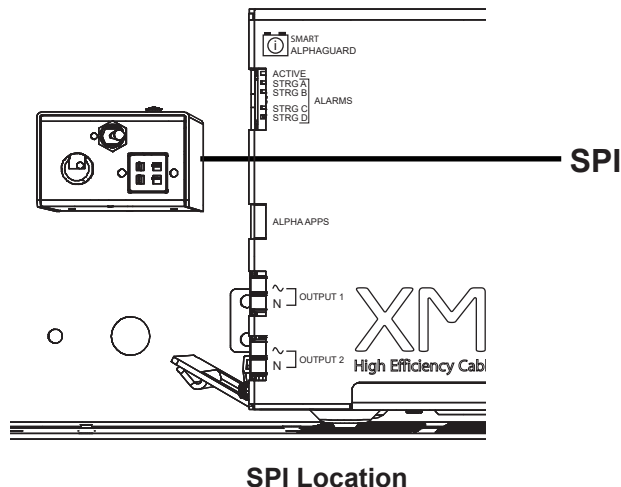

Communications Grounding

For systems using an embedded transponder, the grounding connection is typically made either through a separate chassis ground block bonded to the enclosure or by means of the internal mounting hardware which bonds the transponder through the CableUPS. Please refer to the appropriate communications product manual for installation procedures.

For communication cables, Alpha strongly recommends the use of a surge arresting device electrically bonded to the Alpha Enclosure.



WARNING! ELECTRICAL HAZARD

Low impedance grounding is **mandatory for personnel safety** and critical for the proper operation of the cable system.

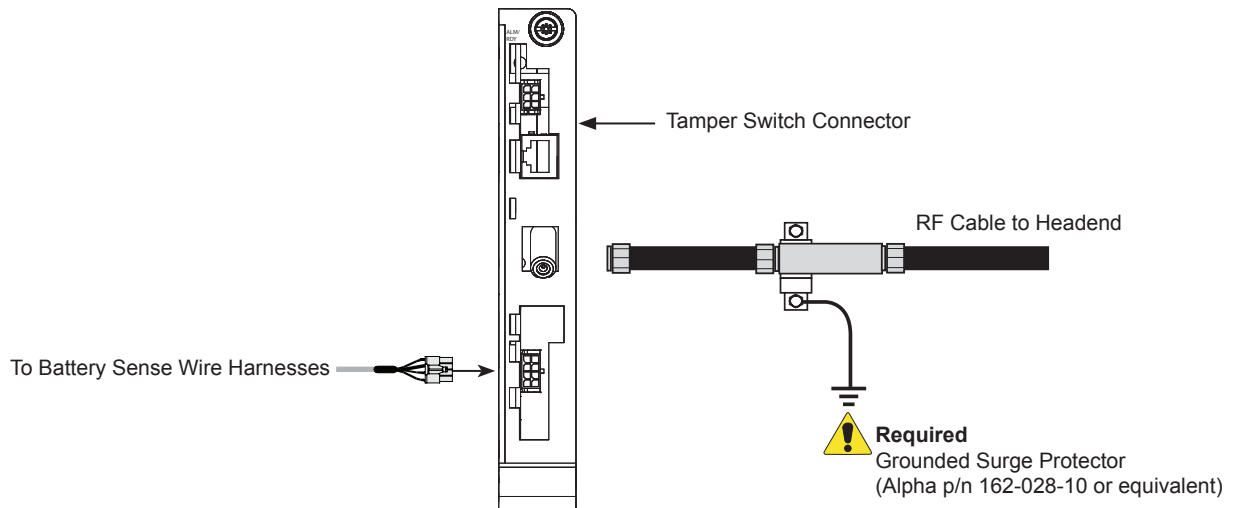

Communications Grounding

1.0 Introduction

1.1 Alpha XM3-HP Intelligent CableUPS®

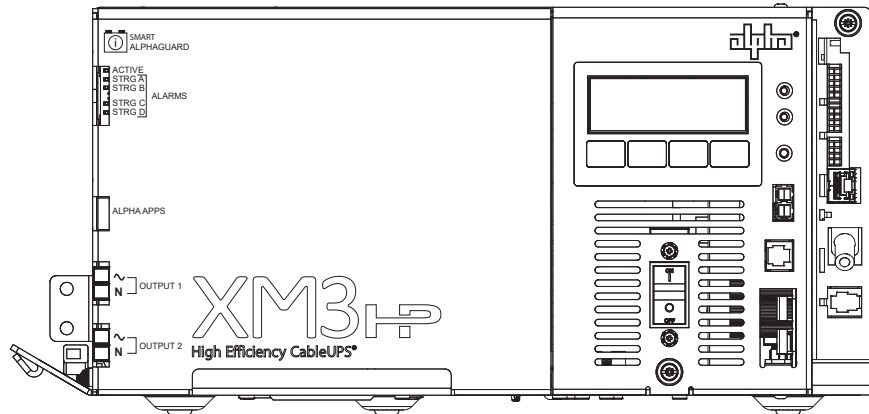

Fig. 1-1, Alpha XM3-HP Intelligent CableUPS

The Intelligent CableUPS® powers signal processing equipment in cable television and broadband LAN distribution systems. The transformer module provides a critical load with current-limited regulated AC power that is free of spikes, surges, sags and noise.

During AC line operation, AC power entering the power supply is converted into a quasi square wave and is regulated by a ferroresonant transformer at the required output voltage. The regulated voltage is connected to the load via the output connectors and some power is directed to the battery charger to maintain a float charge on the batteries.

When the incoming AC line voltage significantly deviates from normal, the Inverter Module automatically switches to standby operation and maintains power to the load. During the switch to standby operation, energy in the module's ferroresonant transformer continues to supply power to the load. In standby mode, the power supply powers the load until the battery voltage reaches a low-battery cutoff point.

When utility power returns, the transformer module waits a short time (approximately 10 to 20 seconds) for the utility voltage and frequency to stabilize and then initiates a smooth, in phase transfer back to AC line power. Once the transfer is complete, the battery charger recharges the batteries in preparation for the next event.

✓ NOTICE:

The duration of battery-backed standby operation depends upon the type and number of batteries and the load on the power supply.

The Alpha XM3-HP CableUPS contains the following:

- Smart Display
- Hot-swappable Inverter Module
- Built-in Self Test
- Wide input voltage range
- High efficiency transformer
- Communications menu with DOCSIS® parameters (only with optional DM3, DSM3 or IDH4 installed)
- Optional factory-installed AlphaDOC (PIM) allows the XM3-HP to provide programmable current limits for two output channels.
- Optional Smart AlphaGuard (SAG)
- Optional AlphaAPPs (APPS) card
- Via the Smart Display, the operator can view all of the power supply's operating parameters.
- Troubleshooting tips automatically display in the Alarm menu screen.
- Built-in metering circuits measure voltage and current, without the need for external test equipment.

✓ NOTICE:

During a no-load start-up, the power supply may reduce output voltage to 75-80% of rated output voltage until a load of greater than 1.5A is applied.

1.2 Theory of Operation

1.2.1 AC (Line) Operation

During AC Line operation, utility power is routed into the primary winding of the ferroresonant transformer through the contacts of the transfer isolation relay. Simultaneously, in the inverter, power is directed to the rectifier circuitry providing power for the control circuitry. The bidirectional inverter also serves as a battery charger during line operation. The ferroresonant transformer and an AC capacitor form the resonant tank circuit, which provides excellent noise and spike attenuation, output short-circuit current-limiting, and output voltage regulation. The ferroresonant transformer produces a quasi square wave output which resembles a rounded square wave.



NOTICE:

When measuring the output voltage of ferroresonant transformers, use only a true RMS AC voltmeter. Non-RMS reading meters are calibrated to respond to pure sine waves and do not provide an accurate reading when measuring *quasi* square wave output.

1.2.2 Standby Operation

When the incoming AC line voltage drops or rises significantly or a complete power outage occurs, the control logic's line monitor activates standby operation. During the transfer from AC line to standby operation, the battery powered inverter comes online as the isolation relay switches to prevent AC power from back-feeding to the utility. The following changes also occur within the power supply:

- The isolation relay opens to disconnect the AC line from the primary winding of the ferroresonant transformer.
- The control logic switches the inverter FETs on and off. This switching action converts the DC battery current into AC current in the inverter windings of the ferroresonant transformer, providing regulated power to the load.
- The control logic, which includes a microprocessor and other circuits to protect the inverter FETs from overcurrent damage, monitors the condition of the batteries and the inverter during standby operation. Since a prolonged AC line outage could severely discharge the batteries, resulting in permanent damage, the control logic disables the inverter when the batteries drop to a predetermined cutoff voltage.
- The XM3-HP offers two user-selectable EOD options based on either overall string voltage or individual battery voltage. See Table 1-1 for battery specific EOD settings. Operation is defined as follows:
 - Battery String Voltage Mode which shuts off the inverter when the 36V bus voltage reaches Low Battery Cutoff Voltage as seen at the inverter.
 - Individual Battery Voltage Mode which shuts off the inverter when any battery in any string (1-4) reaches Low Battery Cutoff Voltage.
 - All units will factory default to Battery String Voltage Mode.
 - Individual battery EOD will only be available (user-selectable) if individual battery voltages are being sensed and present at logic card via the Smart AlphaGuard, DM3/DSM3/IDH4 or other approved status monitor card with individual battery voltage sensing.
 - When set to Battery String Voltage Mode the "Low Battery Cutoff" (EOD) is not user adjustable from the default. See Table 1-1 for more information.
 - When set to individual Battery Voltage Mode the "Low Battery Cutoff" (EOD) will automatically set to default values based on battery type (see Table 1-1). A secondary option is then offered to the user for manually programming the "Low Battery Cutoff" (EOD), regardless of battery type, within the range 1.65 to 1.80 V/C.

1.0 Introduction, Continued

- When set to Individual Battery Voltage Mode, if individual battery voltage is lost, the unit automatically reverts back to Battery String Voltage Mode and "Low Battery Cutoff" (EOD) will revert back to default value based on battery type.

	HP Batteries	GXL Batteries	XTV Batteries	OTHER Batteries
	Fixed	Fixed	Fixed	Fixed
String Low Battery Cutoff (EOD)	30.6 VDC (1.70 V/C)	31.5 VDC (1.75 V/C)	31.5 VDC (1.75 V/C)	31.5 VDC (1.75 V/C)

Individual Low Battery Cutoff (EOD)	Default	Minimum	Maximum
HP Batteries	10.2 VDC (1.70 V/C)	9.9 VDC (1.65 V/C)	10.8 VDC (1.80 V/C)
GXL Batteries	10.5 VDC (1.75 V/C)		
XTV Batteries	10.5 VDC (1.75 V/C)		
OTHER Batteries	10.5 VDC (1.75 V/C)		

Table 1-1, Low Battery Cutoff (EOD)

- When acceptable AC line voltage returns, the power supply returns to AC line operation after a 10 to 20 second lag. This delay lets the AC line voltage and frequency stabilize before the control logic phase-locks the inverter's output to the utility input. The control logic then de-energizes the isolation relay, reconnects the AC line to the primary of the ferroresonant transformer and disables (turns off) the inverter. This results in a smooth, in-phase transfer back to utility power without interruption of service to the load. The battery charging circuit then activates to recharge the batteries in preparation for the next power outage.

1.2.3 Charger Modes of Operation

	AlphaCell Batteries			OTHER Batteries		
	HP	GXL	XTV	Default	Minimum	Maximum
Float V/C	2.25	2.27	2.25	2.27	2.10	2.35
Accept V/C	2.35	2.40	2.35	2.40	2.20	2.45
Automatic 30-Minute Refresh On/Off	ON	ON	OFF	OFF	OFF	OFF
Manual 24-Hour Refresh On/Off	OFF (Programmable)	OFF (Programmable)	OFF (Programmable)	OFF (Programmable)	OFF	ON
Refresh V/C	2.45	2.45	2.45	2.45	2.40	2.50
Rest On/Off	ON	OFF	ON	OFF (Programmable)	OFF	ON
Temperature Compensation	-4mV/°C/cell	-5mV/°C/cell	-3.3mV/°C/cell	-5mV/°C/cell (Programmable)	0 mV/ °C/cell	-5mV/ °C/cell

Table 1-2, Charger Modes of Operation

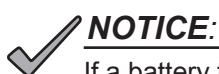

NOTICE:

If a battery type other than an AlphaCell is installed, it is the responsibility of the technician to review the proper charging specifications for the battery used.

1.0 Introduction, Continued

The Alpha XM3-HP uses a three-stage (OTHER battery type), four-stage (AlphaCell GXL and XTV), or five-stage (AlphaCell HP) temperature compensated battery charger as determined by the type of battery used in the system. During AC line operation, the inverter winding on the ferroresonant transformer feeds the charger circuit which provides the appropriate charge voltages to the batteries.

3-Stage Charger Modes (BULK/ACCEPT/FLOAT):

The 3-stage charger is applied when the battery type of OTHER is selected in the Smart Display menu.

BULK charge is a “Constant Current” charge. The maximum current is 10A. As the charge is returned to the batteries, their voltage increases to a specific threshold (2.40VDC per cell). The charger then switches to ACCEPT mode. The BULK charger mode generally returns the battery charge state to 80 percent of rated battery capacity.

ACCEPT charge is a “Constant Voltage” charge. This voltage, default 2.40VDC (programmable 2.20-2.45VDC) per cell, is temperature-compensated to ensure longer battery life and proper completion of the charge cycle. This cycle is complete when the charging current into the batteries becomes less than 0.5A or approximately six hours elapses from the time ACCEPT mode was entered, at which time the charger switches to the FLOAT mode of operation.

FLOAT charge is a temperature-compensated charge, default 2.27VDC (programmable 2.10-2.35VDC) per cell. During FLOAT mode, the batteries are fully charged and ready to provide backup power. The charger provides a small maintenance charge to overcome the batteries self-discharge characteristics and other minor DC loads within the power supply.

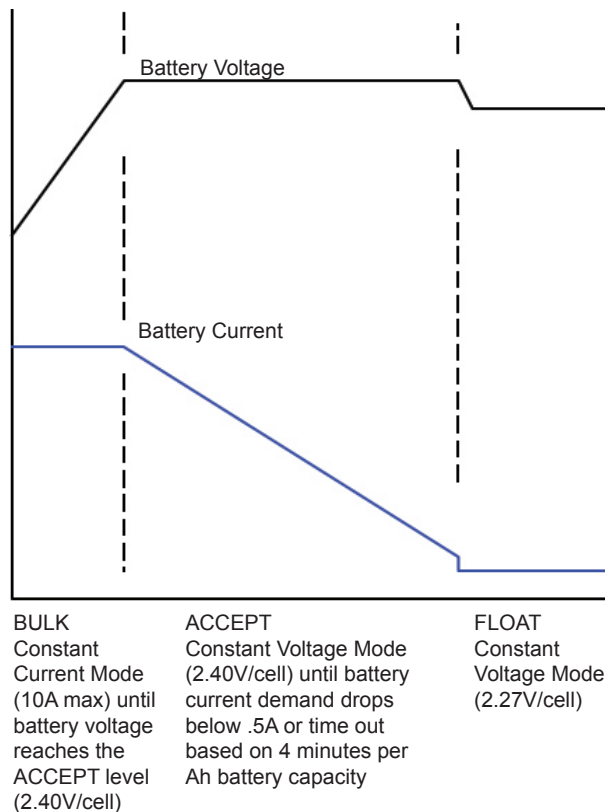

Fig. 1-2, 3-Stage Charger Modes

1.0 Introduction, Continued

4-Stage Battery Charger (BULK/ACCEPT/REFRESH/FLOAT):

This preset value is applied to AlphaCell GXL batteries when selected in the Smart Display Menu.

A 30-minute REFRESH charge is added, after BULK and ACCEPT states, before dropping down to FLOAT state, when the batteries are discharged more than 30% and it has been more than 30 days since the last REFRESH charge.

A manual REFRESH charge mode is recommended to be applied to all new batteries upon installation. This mode “boosts” the individual cell voltage of batteries that may have been in storage before they were placed on permanent FLOAT. Refresh can be initiated manually via menu selection or automatically when the battery date code is updated (See **Section 3.3.2, Battery Information and Configuration** for further instructions). The REFRESH charge is a one-time, 24-hour charge to raise individual cell voltage to 2.45VDC, and may bypass the BULK and ACCEPT states if the batteries are fully charged. The batteries are temperature-compensated at -0.005VDC per cell per degree C to ensure safe battery cell voltage and maximize battery life.

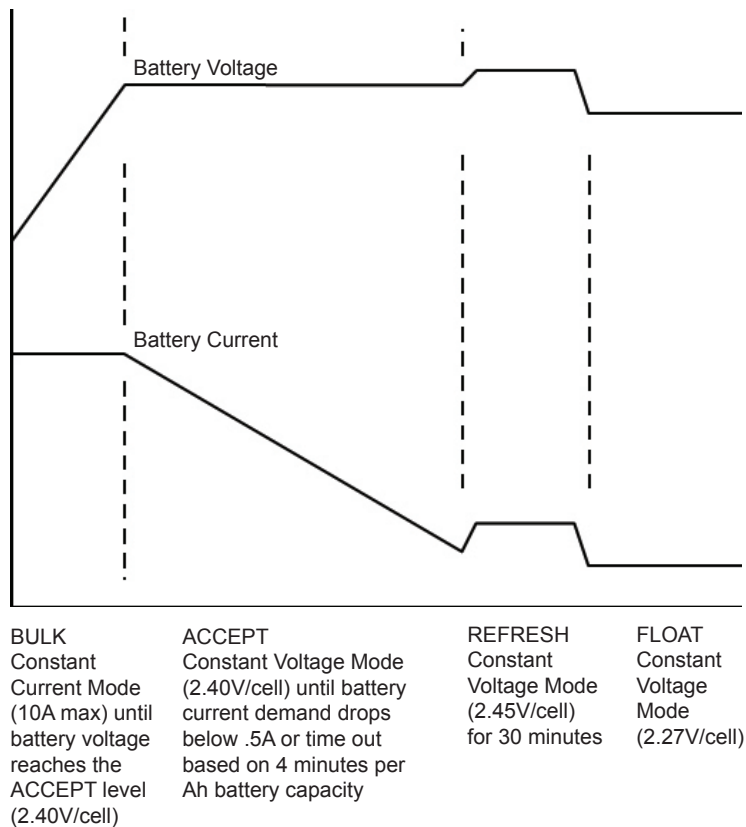

Fig. 1-3, 4-Stage Charger Modes

1.0 Introduction, Continued

4-Stage Battery Charger (BULK/ACCEPT/FLOAT/REST):

This preset value is applied to AlphaCell XTV batteries when selected in the Smart Display Menu.

A REST stage is added, after BULK, ACCEPT and FLOAT states.

A manual REFRESH charge mode is recommended to be applied to all new batteries upon installation. This mode “boosts” the individual cell voltage of batteries that may have been in storage before they were placed on permanent FLOAT. The REFRESH charge is a one-time, 24-hour charge to raise individual cell voltage to 2.45VDC, and may bypass the BULK and ACCEPT states if the batteries are fully charged. The batteries are temperature-compensated at -0.005VDC per cell per degree C to ensure safe battery cell voltage and maximize battery life.

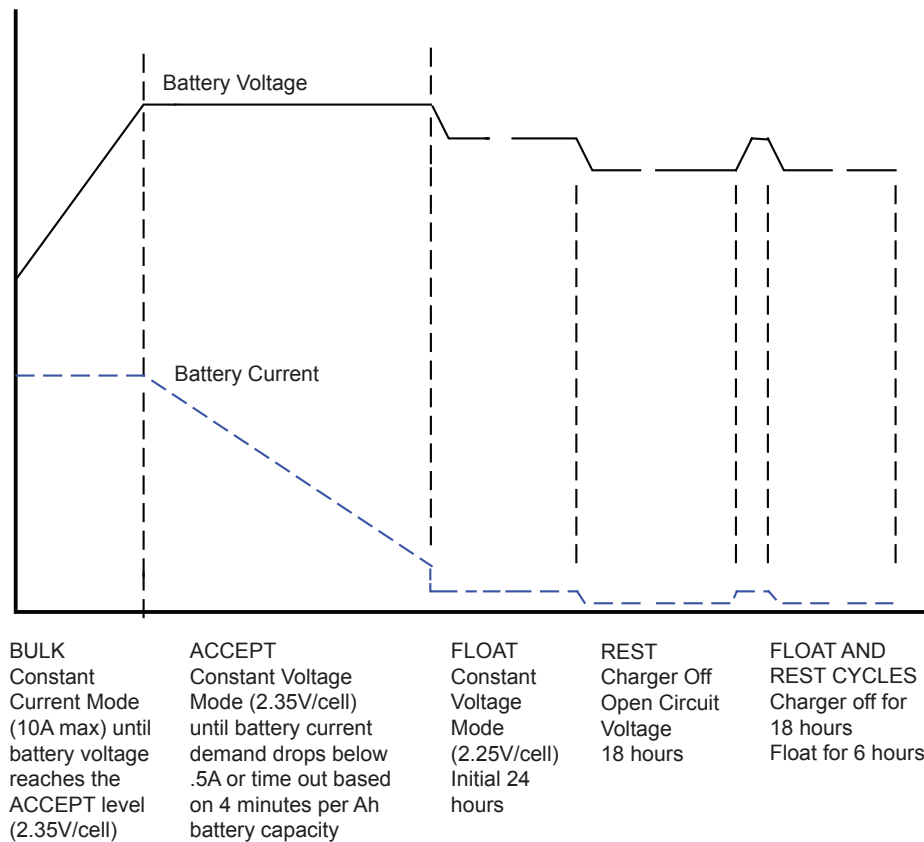

Fig. 1-4, 4-Stage Charger Modes for XTV Batteries

1.0 Introduction, Continued

5-Stage Battery Charger (BULK/ACCEPT/REFRESH/FLOAT/REST):

This preset value is applied to AlphaCell HP batteries when selected in the Smart Display Menu.

REST: Charger is turned off (if ENABLED) and leaves the batteries without external voltage applied on the battery. Removing charged voltage and allowing the battery to sit in an open circuit environment maximizes the battery life by eliminating the chance of overcharging individual cells inside the 12V battery.

If the Smart AlphaGuard (SAG) is installed and the battery harness is connected, the unit will not go into REST mode until the SAG indicates that any batteries are less than or equal to 0.3V out of balance, or until 4 days per string has elapsed, whichever comes first after the 6 hour float period.

After any discharge/recharge cycle, once the charger reaches FLOAT mode, it will wait 24 hours in FLOAT mode before going to REST mode. On a daily basis, without any discharge cycle, the batteries will be in FLOAT for 25% and REST (charger off) for 75% (6 hours float, 18 hours rest).

REST mode is terminated if voltage drops to less than 2.12VPC. Upon exiting REST mode due to a voltage below 2.12VDC, a BULK/ACCEPT cycle will be initiated.

The battery charger voltage is temperature-compensated at -0.004VDC per cell per degree C to ensure a safe battery cell voltage and to maximize battery life.

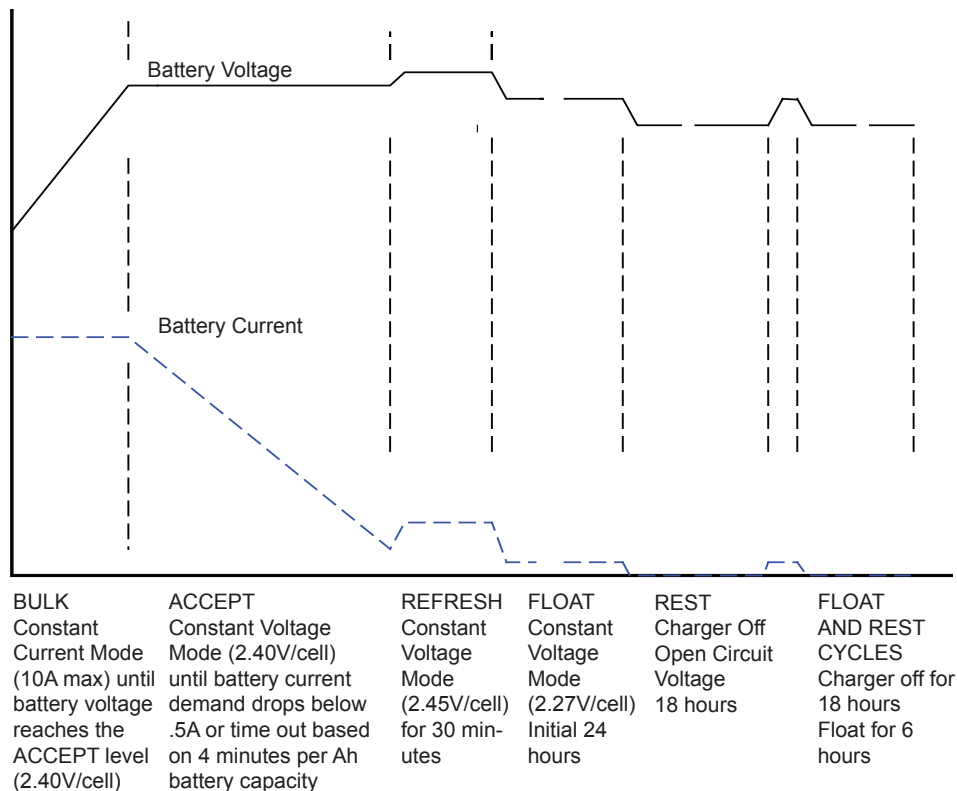

Fig. 1-5, 5-Stage Charger Modes

1.0 Introduction, Continued

1.2.4 Output Voltage Modes of Operation

The XM3-HP can be configured to Fine or Coarse Mode of operation for Output Voltage Regulation via the Power Configuration Menu (see **Section 3.3.1, Power Information and Configuration**).

Fine Mode:

In Fine Mode the power supply will maintain the tightest output voltage regulation possible, $+1/-2.5\%$ for 89V or $+1.5/-3.5\%$ for 63V. It will automatically adjust to and from Coarse Override Mode temporarily if:

- a) The unit switches to inverter more than 2 times in a 60-day period;
- b) the unit switches tap relays more than 60 times in a 60-day period.

The power supply will automatically adjust back to Fine Mode if there are less than 2 inverter transfers and less than 15 output tap switches in a 60-day period.

Coarse Mode:

In Coarse Mode the XM3-HP will maintain a wider output voltage regulation window, $+1/-5\%$ for 89V or $+1.5/-6\%$ for 63V. In this mode the power supply switches taps as few times as possible. It will never automatically adjust to Fine Mode once Coarse Mode is selected.

1.3 Alpha XM3-HP CableUPS® Layout

The Intelligent CableUPS is comprised of the following:

Transformer module, which acts as a stand-alone line conditioner. The transformer module contains a ferroresonant transformer, ferroresonant capacitor, line isolation relay, Power Distribution Board, EMC Filter board and the optional AlphaDOC (PIM) board, Smart AlphaGuard (SAG) and Alpha APPS card.

NOTICE:

The option cards require an Inverter Module installed in order to be functional.

Intelligent Inverter Module, which is required for standby operations and contains circuitry needed for the three-to-five-stage temperature-compensated battery charger, DC to AC inverter, AC line detectors and Smart Display.

Optional DOCSIS Communications Module (interfaces to Inverter Module) provides remote status monitoring and communications.

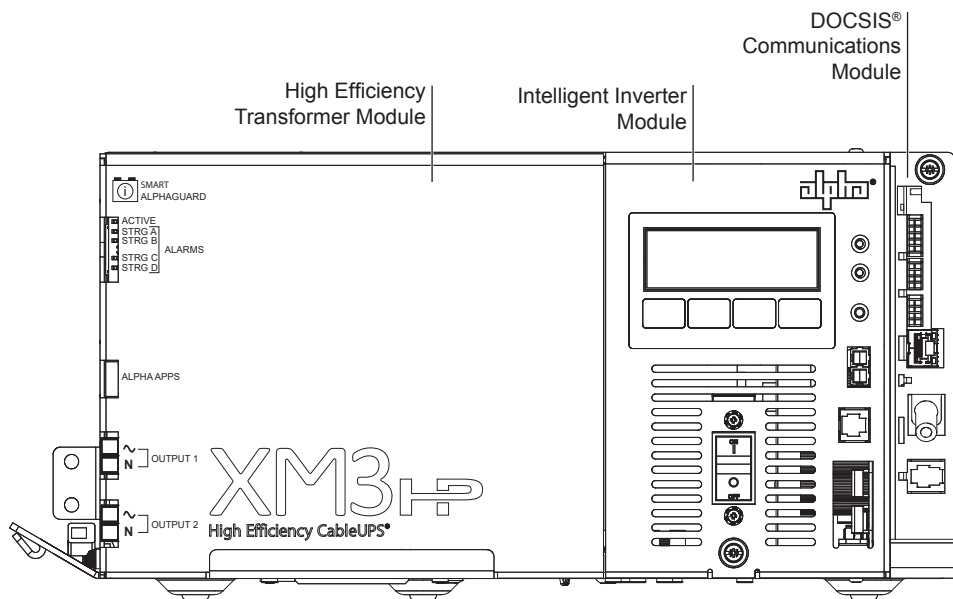

Fig. 1-6, Front Panel, XM3-HP Power Supply

1.3.1 Side Panel Connectors

- 1 AC Input Line Cord Connector
- 2 Optional Smart AlphaGuard Connector
- 3 Optional APPS Card
- 4 Output 1 Connector
- 5 Output 2 Connector

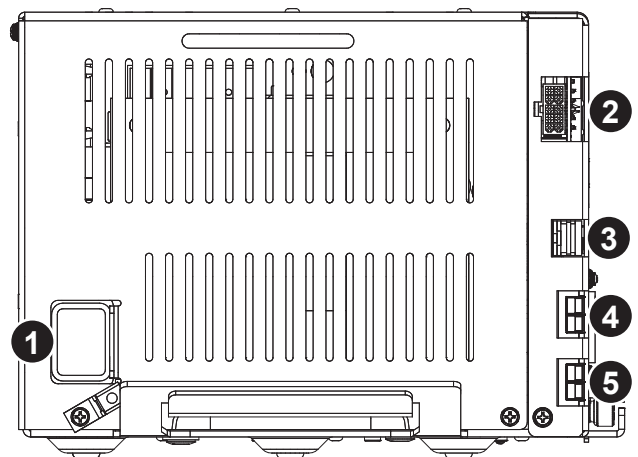

Fig. 1-7, Side Panel, XM3-HP Power Supply

1.0 Introduction, Continued

1.3.2 Front Panel Indicators

Circuit boards for the optional Smart AlphaGuard (SAG), Alpha APPS card and the two-output AlphaDOC are located behind the removable front panel.

- 1 Smart AlphaGuard (SAG): Enables the XM3 to gather battery voltage data for up four battery strings (A through D). Its Charge Management Technology applies excess charge current to batteries as needed to maintain balanced voltages throughout the string. See **Section 1.3.4, Smart AlphaGuard** for connection information and LED functionality.
- 2 Alpha APPS Card
- 3 Output 1 (White = Neutral, Black = Line): The AC output connector is clearly marked and color-coded for easy identification. The Service Power Inserter (SPI) connects directly into the Output 1 connector.
- 4 Output 2 (White = Neutral, Black = Line): When no AlphaDOC is installed, this output is wired in parallel to Output 1 and is often used for auxiliary loads. If the AlphaDOC is installed, Output 2 can be isolated from Output 1.

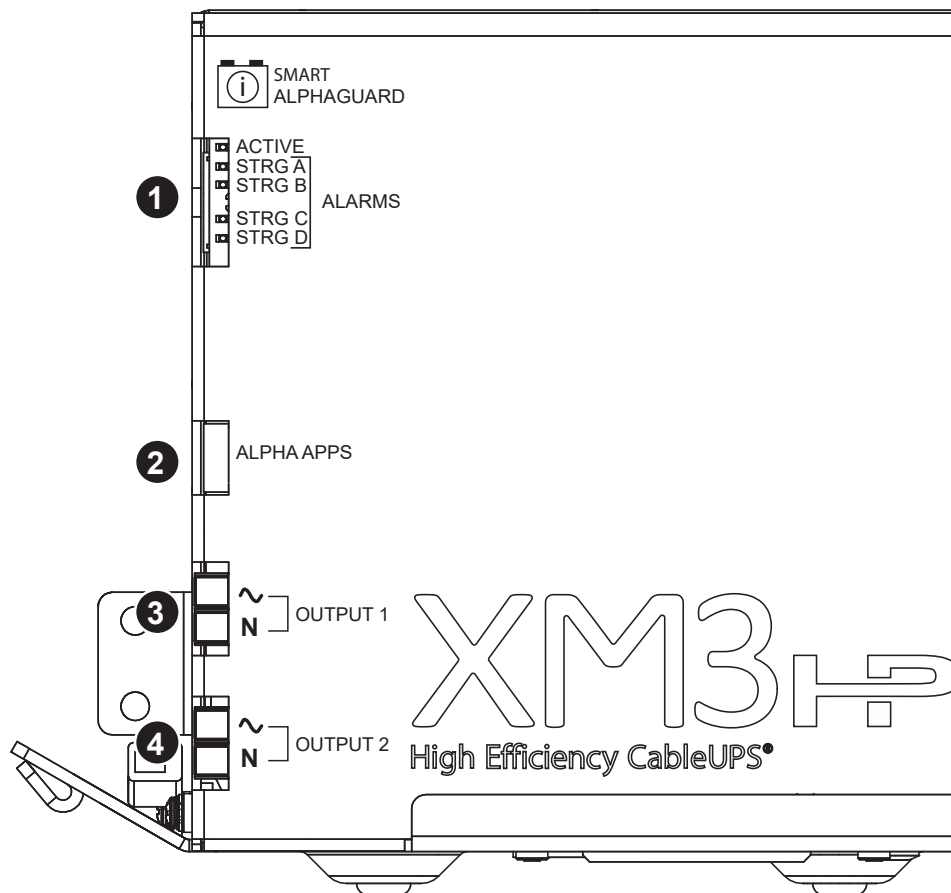

Fig. 1-8, Detail View, Front Panel Connections and Indicators

1.0 Introduction, Continued

1.3.3 AlphaDOC (Dual Output Controller)

The optional AlphaDOC adds a second isolated output to the power supply. It provides programmable current limits for two output channels and protects system components by shutting down the load during overcurrent and short circuit conditions. The AlphaDOC is similar in function to the Programmable Interface Module (PIM) that is available for the XM2 Series.

The AlphaDOC has a programmable overcurrent threshold (3A-25A) and overcurrent tolerance period that specifies the time (20-9900ms) an overcurrent condition is permitted before shutting down.

The programmable retry limit can be programmed to select how many times (0-40) after a programmable delay (5-301 seconds) the AlphaDOC will attempt to reconnect an output once it has been shut down. When the limit is reached, the XM3 power supply automatically retries once every 30 minutes until the fault clears.

Adding the AlphaDOC to the power supply provides these advantages:

A second isolated output: The main purpose of the AlphaDOC is to limit the impact of a fault condition in one output channel. If a fault condition occurs in a power supply (without the optional AlphaDOC installed) the entire customer network can be affected. The AlphaDOC option affords protection to one output should a fault condition exist on the other. This gives you flexibility to isolate Output 1 from Output 2.

A current for critical loads: With the AlphaDOC option, you can designate one output as the primary connection and the other output as the secondary connection. Commonly, critical loads are connected to Output 1 as the primary feeder. Using the overcurrent limit settings, you can ensure the primary output always provides the necessary power. For example, on a 15 Amp power supply, if a customer needs 10 Amps available on Output 1, the overcurrent limit for Output 2 is set at 5 Amps, so regardless of Output 2, 10 Amps will remain available for the primary Output 1.

Additional current protection: The standard power supply current limit protection is provided by the fold-back characteristics of the transformer (150% of rated output). The 150% current limit may exceed the ratings of active devices in the cable network and cause failures. You can lower the maximum current provided at each output by lowering the overcurrent limit of each respective output. Therefore, to minimize failures due to excess current supply, set the overcurrent limit to a value below the maximum current the active components can tolerate.

NOTICE:

The table below depicts a condition in which no DOC is installed, or no individual output is above its trip setting.

Power Supply Load		Duration
918 and 918D	All Other Models	Permitted Duration of Load
>125%	>150%	30 seconds
113% to 125%	125% to 150%	10 minutes
108% to 113%	115% to 125%	30 minutes
<108%	<115%	Several months

Table 1-3, Duration of Load

For example, on a 18A power supply, where both outputs are programmed to 10A maximum and both outputs are supplying 10A, neither output is “in violation” but the total system at 18A is operating at 111% of its rated output. In this example, after 30 minutes, the power supply will begin a “load shedding” algorithm. The first action is to disconnect Output 2. If this does not correct the system overload, the next action is to disconnect Output 1.

1.0 Introduction, Continued

Installing the AlphaDOC

NOTICE:

Only qualified personnel should install the AlphaDOC. To install the AlphaDOC you must completely shut down the power supply. To maintain output to the load, consider using either the APP9015S or APP9022S Service power supply during installation.

WARNING! ELECTRICAL HAZARD

To avoid exposing the technician to potentially lethal voltages, before you proceed you must remove all power from the power supply; unplug the power supply from the AC power source, remove all front panel connections and disconnect the battery connector.

Tools Required:

3mm slotted screwdriver
#2 Phillips-head screwdriver

To install the AlphaDOC

1. Completely shut down the power supply; verify all power is removed. Ensure utility power is off and battery power is safely secured (or not installed) in the enclosure assembly. All connections and cables must be removed from the power supply. To maintain output to the load, consider using the APP9015S or APP9022S Service power supply when installing the AlphaDOC.
2. To remove the transformer module's front panel, remove the three front panel screws (one from the bottom left, two from the top).
3. Remove the output voltage wires from the terminal block, see Fig. 1-9.
4. Remove the ribbon cable.
5. Lift the front panel up and away from the chassis.
6. Remove the 6-32 KEPS nut securing the single-output wire harness and output connector bracket.
7. Replace with the AlphaDOC board and dual output wire harness assembly.
8. Attach the nomex to the back of the PCB using the two 3/8" circuit board supports.
9. Install the output connector bracket using the 6-32 KEPS nut that was removed in Step 6 on the PEM stud that is farthest from the connectors.
10. Install the PCB using two 6-32 screws, routing the wires under the PCB and nomex as shown.
11. Connect the dual output voltage wires (Fig. 1-10), to the output voltage terminal block as shown, see Fig. 1-9. Torque terminal block screws to 7in-lbs (0.79N-m).
12. Replace the front panel.
13. Replace connections and return the unit to service.

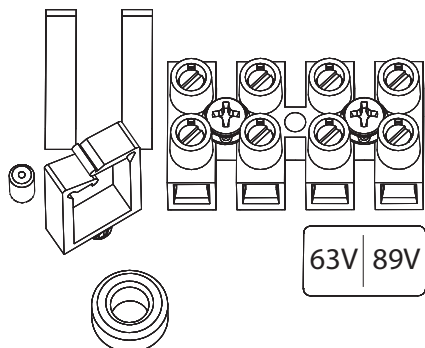

Fig. 1-9, Output Voltage Terminal Block

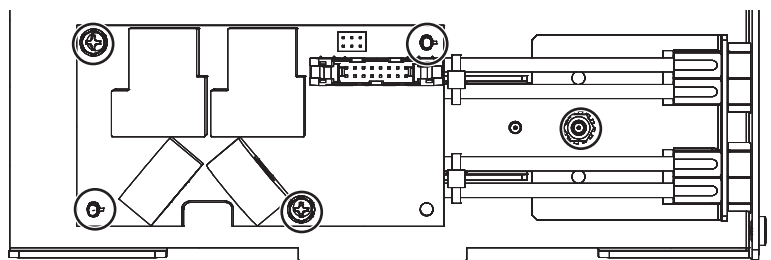

Fig. 1-10, AlphaDOC Standoff and Screw Locations

1.0 Introduction, Continued



NOTICE:

For XM3-910E-HP and XM3-615CE-HP models, a 5-position terminal block is included, see Fig. 1-11.

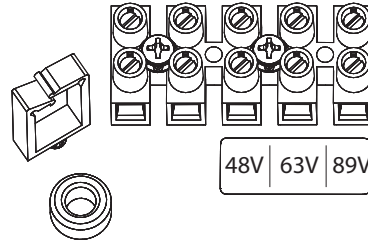

Fig. 1-11, 5-Position Output Voltage Terminal Block

Programming the AlphaDOC

Programmable parameters (with AlphaDOC installed) are:

Channel 1 Overcurrent Limit: The RMS current level that causes the Output 1 protection relay to trip after a specified delay (overcurrent tolerance period).

Channel 2 Overcurrent Limit: The RMS current level that causes the Output 2 protection relay to trip after a specified delay (overcurrent tolerance period).

Retry Delay: The time between each attempt to restart an output in the event of an overcurrent event.

Retry Limit: The number of times the power supply attempts to restart an output connection. Once the RETRY LIMIT is exceeded, standard models attempt to restart the output connection every 30 minutes. Set this parameter to “zero” to disable the “automatic retry” function.

Overcurrent Tolerance Period (20-9900ms): In the event of an overcurrent episode, the amount of time an output overcurrent condition is permitted on either output connection. Once this time expires, the output protection relay disables its output feeder.

Output 1 Reset/Output 2 Reset: This manually resets corresponding tripped output. These are not displayed if the corresponding output is not tripped.



NOTICE:

Programming any of the above parameters will reset the “trip/retry” counters.

Read Only AlphaDOC Menu Items:

AlphaDOC Option: Automatically senses and indicates whether the AlphaDOC is installed.

AlphaDOC FW: Firmware version installed in the AlphaDOC.

DOC #####: Serial number of the AlphaDOC.



NOTICE:

If the optional AlphaDOC is not installed, the values shown under the “AlphaDOC OPTION” line of the Smart Display are hidden.

1.0 Introduction, Continued

1.3.4 Smart AlphaGuard

The Smart AlphaGuard (SAG) is an optional device that maximizes battery life.

The SAG enables the XM3-HP system to gather individual battery voltages and balance the batteries. A description of the SAG's operation and features follows.

Theory of Operation

The Smart AlphaGuard (SAG) communicates directly with the XM3. The SAG sends battery data, unit states and alarms to the XM3 and the XM3 sends control messages back to the SAG.

The SAG is a battery balancer with multiple string capability and integrated intelligent functions. It minimizes differences in individual battery voltages during the charging of the batteries (all modes except REST) by transferring charge from a battery with a higher voltage to the batteries with lower voltages within a string. The SAG's balancer circuit switches between strings enabling a single SAG to service up to four strings of batteries.

To accomplish this the SAG periodically measures all the battery voltages. These measurements are sent to the system master XM3. Voltage measurements are used to determine the level of balance of the batteries and determine if there is one or more batteries that need to be balanced. The level of balance will determine which string the SAG will focus on. The SAG selects the string with the highest delta mean ($V_{bat} - V_{mean}$) to balance first.

Units configured with XM3 firmware V1.13.0 and higher, will have the Smart AlphaGuard (SAG) battery balancer disabled at initial power up. Once the battery charger reaches FLOAT charging mode (the charging time may vary due to battery state and condition), the power supply will perform a mandatory automatic two-minute self-test to verify the health of the battery strings. Upon successful completion of the test, the SAG battery balancer will be enabled. If the self-test fails, refer to the Smart Display to view any active alarms.

If the unit displays a "Self-Test Fail" alarm, the alarm is latched and cycling the XM3-HP Inverter Module will not clear the alarm. It will be necessary to clear the fault condition and re-run the Self-Test.

The SAG option does not support the AlphaCell XTV 18v4 battery, battery balancing will be disabled.

1.0 Introduction, Continued

Connections

The connection from the embedded SAG to the battery strings are made with one of the orderable wire kits. Kits for one, two, three, or four strings are available. Kits are also available that mate to the external AlphaGuard wire kit. The SAG wire kit consists of a string 36V positive and a string negative that are common for all strings. For each string (A, B, C and D), there are two additional wires that must be connected.

Wire kits

New install with embedded SAG

- 1 string Battery harness p/n 875-848-20
- 2 string Battery harness p/n 875-848-21
- 3 string Battery harness p/n 875-848-22
- 4 string Battery harness p/n 875-848-23

Upgrade with external AlphaGuard wire kits in place

- 1 string Battery harness p/n 875-910-20
- 2 string Battery harness p/n 875-910-21
- 3 string Battery harness p/n 875-910-22
- 4 string Battery harness p/n 875-910-23

Adaptor Cable

SAG to Status Monitor p/n 876-003-20
(please contact Alpha Technologies Inc. for full details).

Single battery string

A single string system must use String A on the wire harness.

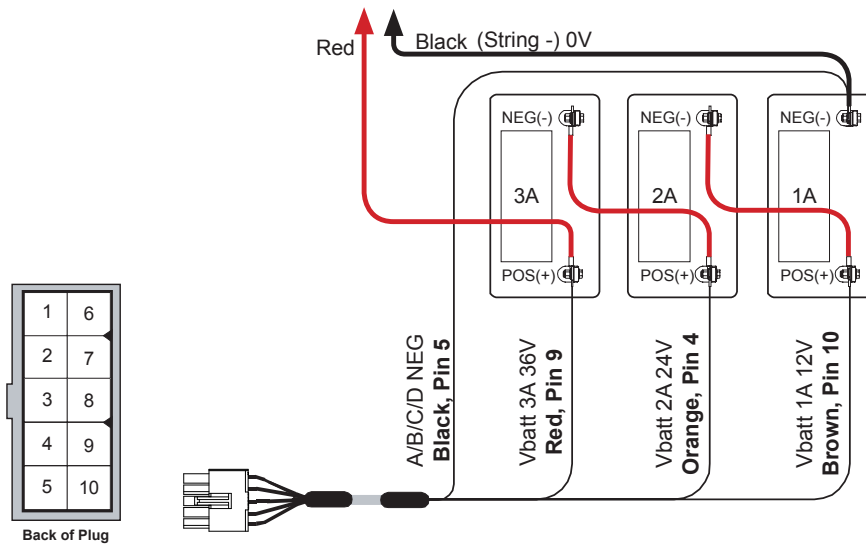

Fig. 1-12, Single Battery String Wiring Diagram (w/ embedded SAG Harness depicted)

1.0 Introduction, Continued

Dual battery string

A dual string system must use String A as the first string and String B as the second.

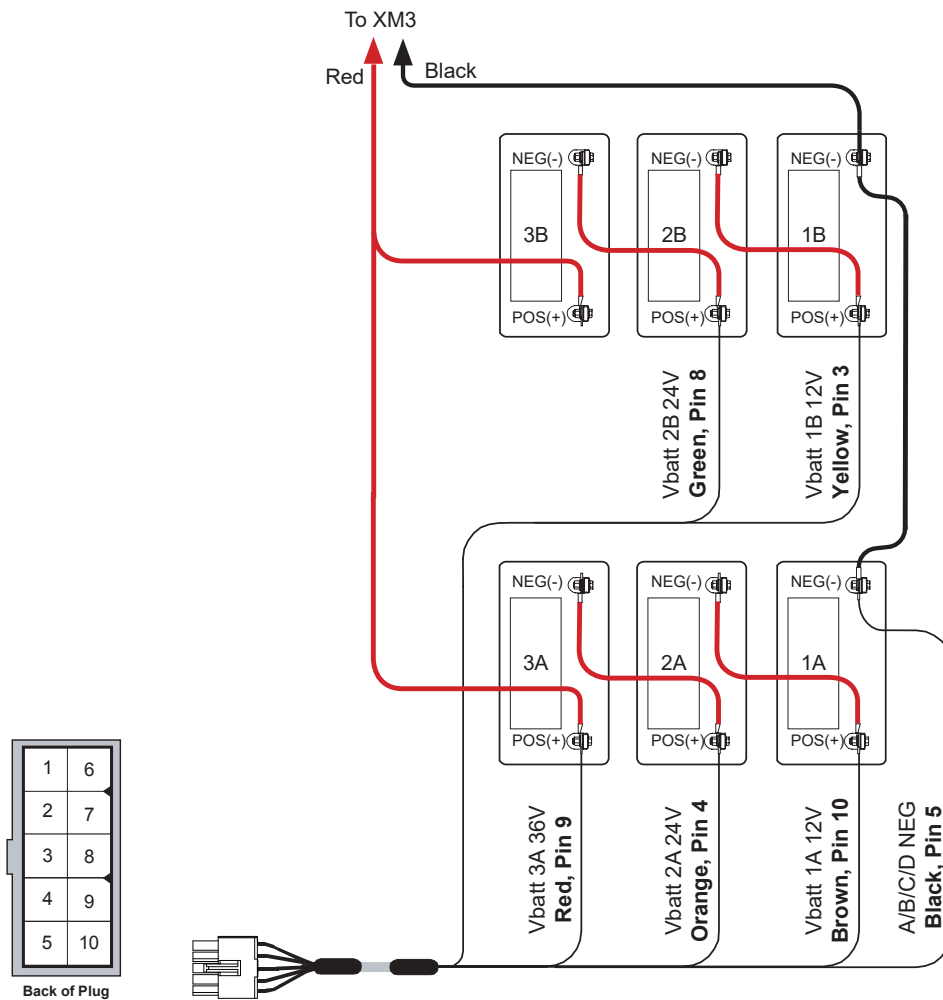

Fig. 1-13, Dual Battery String Wiring Diagram (w/ embedded SAG Harness depicted)

1.0 Introduction, Continued

Multiple battery strings

A system with multiple strings must use String A as the first string, B as the second, C as the third and D as the fourth.

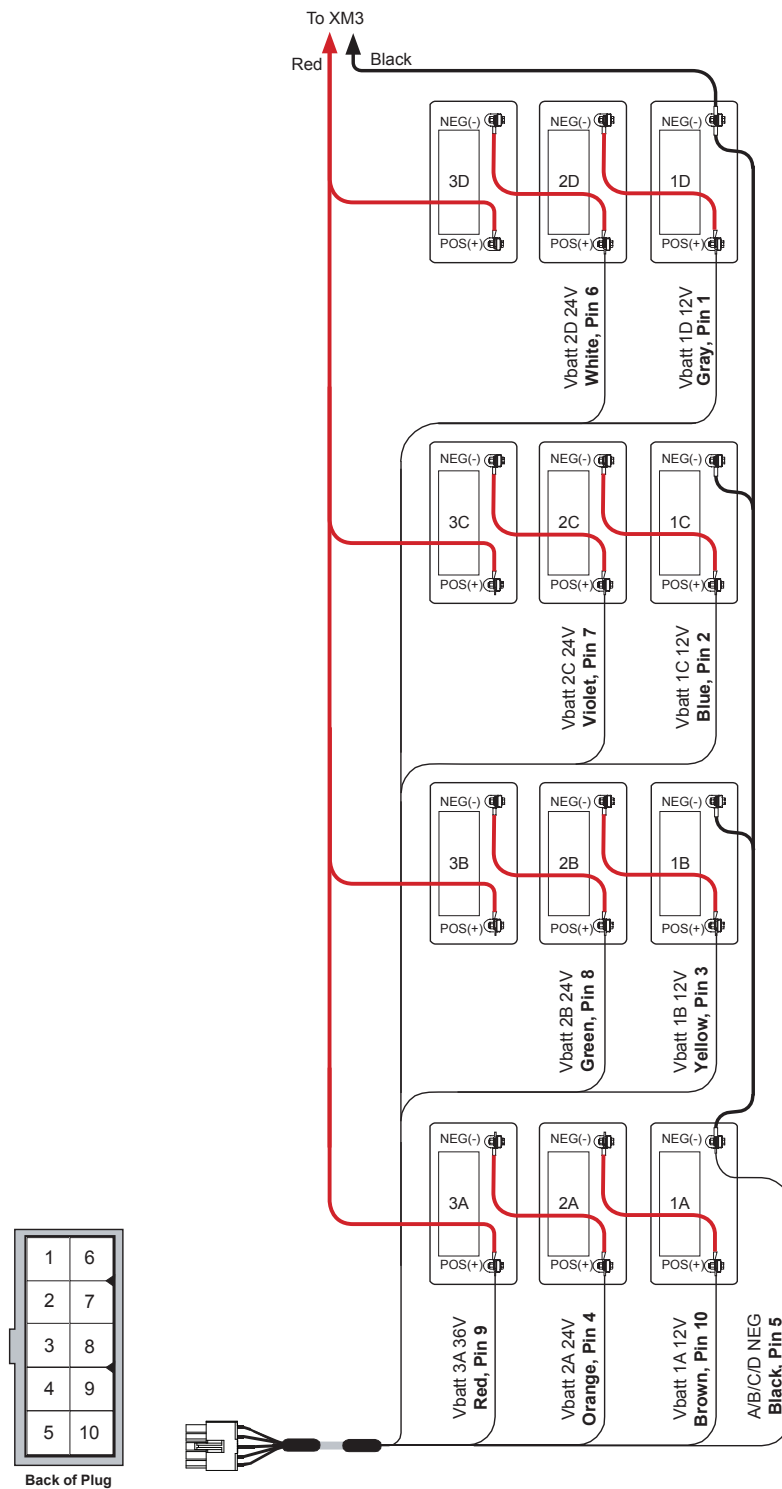

Fig. 1-14, Multiple Battery String Wiring Diagram (w/ embedded SAG Harness depicted)

1.0 Introduction, Continued

Alarms

The alarms are available through the LEDs and through the status monitoring card.

Definitions – SAG Alarms via Class Information Base (CIB)

Miswired – PS Minor

The SAG will verify a string is correctly wired before it will add it to the list of battery strings to balance. If it detects the wires are reversed or only one battery is connected, the alarm will activate. This alarm may also activate if a battery is outside the valid voltage range of 9.9V to 15.7V.

High delta mean – PS Minor

The SAG compares all measured voltages to a calculated mean voltage. This is the ideal voltage of the battery based on the total string voltage divided by the total number of batteries in the string. The alarm activates immediately if a battery in the string gets more than 500mV from the calculated mean voltage.

Check battery – PS Minor

The SAG keeps track of the balancing duration of all valid strings. If a string has a battery that will not balance to within 150mV of the calculated ideal battery mean with three weeks of balancing, then the alarm will be set. The suspect battery will be flagged in the status monitor information. The whole string should be checked as two suspect batteries can cause an alarm on a good battery.

Stuck relay – PS Minor

Relays isolate the battery strings. The SAG provides a safety measure by verifying that the relays have opened before it turns on a new string. The SAG will activate the alarm and discontinue balancing until the alarm has cleared if the relays do not open properly.

No Harness – PS Minor

The SAG will verify that there is a harness connected before evaluating any other alarms.

Not Calibrated – PS Minor

The SAG checks the calibration data stored in memory to ensure the voltage readings are accurate. If the data is not present, the alarm is activated.

SAG Fuse Protection – PS Minor

The SAG option has been temporarily disabled due to a heavily degraded battery string. Check the condition of the batteries. Supported in XM3 inverter firmware version 1.14.0 and higher.

SAG Compatibility – PS Minor

The SAG option has been disabled. The SAG battery balancer does not support the connected battery models (such as the XTV 18V4 battery) or the SAG card voltage and system voltage do not match (such as a 24V SAG installed in a 36V system). AlphaCell XTV 18V4 batteries are supported in XM3 inverter firmware version 1.14.0 and higher.

1.0 Introduction, Continued

LEDs

The LEDs provide visual indications of the current state of the SAG and any alarms that are present.

LED ALARM STATES			
LED name	Color	State	Function
Active	Green	Off	No power to SAG
		Solid	Unit is on and communicating with power supply or in Rest mode
		Flash (90% on / 10% off)	Unit is on and not communicating with power supply
		Flash (50% on / 50% off)	Actively balancing
		Flash (10% on / 90% off)	Powersave mode/SAG disabled
STRG A STRG B STRG C STRG D (ALARMS)	Red	Off	Normal operation No string wires connected
		Flash (50% on / 50% off)	High delta mean Check battery alarm
		Flash (10% on / 90% off)	Stuck relay alarm
		Solid	String A missing String miswired
ALL STRG			Battery outside valid range No harness connected or all strings are miswired

Table 1-4, Smart AlphaGuard LED Alarm States

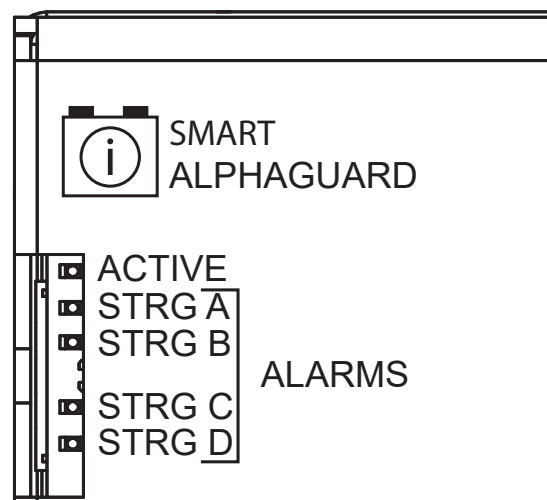

Fig. 1-15, SAG Front Panel

1.0 Introduction, Continued

Troubleshooting

High delta mean alarm during charging

A high delta mean alarm during charging is usually seen when one battery has either higher or lower capacity than the other two batteries. This may be seen on initial install of unbalanced batteries. Verify that the alarm clears within 7 days. Otherwise, investigate the batteries.

High delta mean during discharging

A high delta mean alarm during discharging is usually seen when one battery has either higher or lower capacity than the other two batteries. The SAG cannot compensate for reduced capacity batteries in discharge mode to maintain balance. Investigate the batteries.

Miswired string alarm during discharging/charging

A miswired string alarm occurs when a battery voltage is not within the specified valid battery range of 9.9V to 15.7V, but the other batteries are in valid ranges. During discharge, a battery with a much lower capacity will have a voltage that is much lower than the others in the string. This can cause the low capacity battery voltage to fall outside the limits of a valid battery, and the SAG may identify the string as miswired. Investigate the batteries.

Maintenance required and stuck relay alarm at the same time

This is normal alarm operation. A stuck relay alarm will trigger an alarm in the SAG and the XM3 will trigger a maintenance required alarm. Replace the unit if the alarm does not clear itself.

PowerSave / SAG Disabled Mode

When the "turn off" logic command is received the SAG initiates a power save mode. In this mode the software disables the balancer including all relays and it turns off all the LEDs with the exception of the active LED, which flashes with a 10% on, 90% off preset interval. It only detects voltages on a query from the power supply.

When 18V4 XTV batteries are installed, the SAG compatibility alarm will display on the XM3's LED and the SAG will initiate PowerSave/SAG Disabled Mode.



NOTICE:

If retrofitting a 36V system to 18V, it is recommended to have the SAG disconnected both externally to the batteries and internally to the XM3 when 18V4 XTV batteries are installed.

Preventive maintenance required and high delta mean alarm at the same time

This is normal alarm operation. A high delta mean alarm will trigger an alarm in the SAG and the XM3 will trigger a preventive maintenance required alarm. Investigate the battery condition if the alarm persists.

1.0 Introduction, Continued

1.3.5 Inverter Module Overview

The removable Inverter Module provides uninterrupted power to the ferroresonant transformer (via the batteries) during utility failures. During normal operation, the inverter charges the batteries using a three-, four- or five-stage (Bulk, Accept, Refresh, Rest and Float) charging protocol determined by the charger setting and battery type.

- 1 Smart Display: All operational functions, system testing, programmable items and alarms are available via the Smart Display panel on the front of the power supply.
- 2 Softkeys: Provide access to the various menus and submenus within the Alpha XM3-HP.
- 3 Output LED: Indicates output state of the Alpha XM3-HP.
- 4 Alarm LED: Indicates Alarm condition.
- 5 Self Test button: Initiates Self Test.
- 6 Local/Remote Indicator Connector: Indicates alarm condition to exterior lamp.
- 7 The Precision Temperature Sensor (PTS): Plugs directly into the Temperature Probe (RJ-11C type) Connector.
- 8 Battery Circuit Breaker: Controls battery DC power to the inverter.
- 9 Battery Cable Input Connector: The battery cable connector plugs directly into the Inverter Module's battery input connector. The connector is polarized and fits in one direction only.

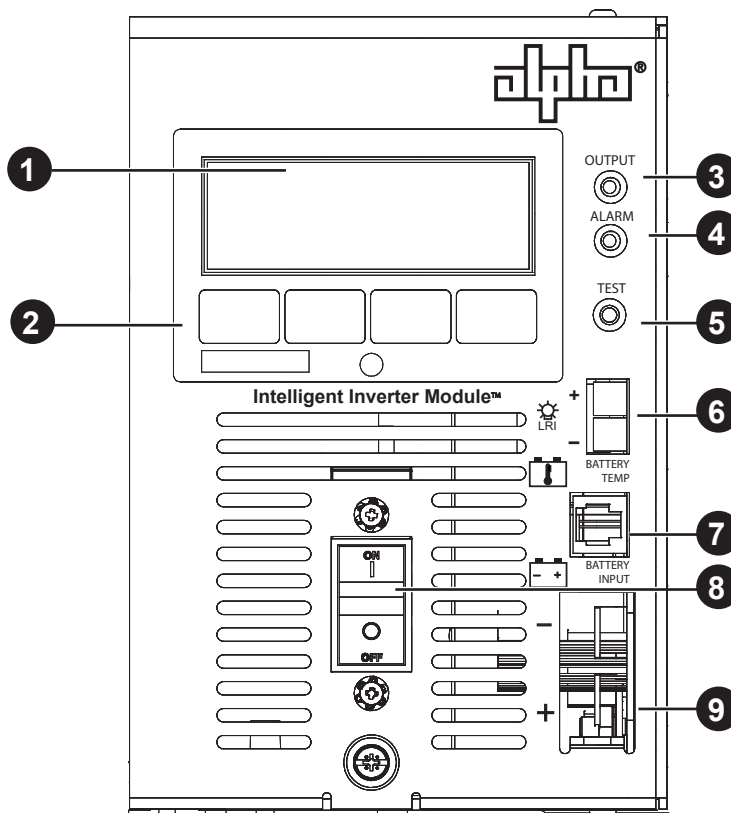

Fig. 1-16, Inverter Module Connections

1.0 Introduction, Continued

1.3.6 Optional DOCSIS Status Monitoring Transponders

The power supply supports several Alpha communication modules which may be ordered factory-installed or as a user-installed field upgrade (for full installation instructions refer to the communication module technical manual). The AlphaNet DSM3, IDH4, and DM3.0 Series Embedded DOCSIS Status Monitoring Transponders allow monitoring of Alpha power supplies through existing cable network infrastructure. Advanced networking services provide quick reporting and access to critical powering information.

The communications modules utilize Simple Network Management Protocol (SNMP) and standard Management Information Bases (MIBs) to provide network status monitoring and diagnostics. A Web interface enables authorized personnel direct access to advanced diagnostics using a common Web browser. This manual addresses all models and is based on the DSM3x, which has the complete feature set. Table 1-5 compares the differences between the transponder models.

Status Monitoring Features									
Transponder Features	AlphaNet DSM Series			AlphaNet IDH4 Series		AlphaNet DM3.0 Series			
	DPM	DSM3	DSM3x	IDH4L	IDH4x	DM3	DM3X	DM3E	DM3EX
DOCSIS 3.0 Compatible						x	x	x	x
DOCSIS 2.0, ANSI/SCTE HMS Compatible	x	x	x	x	x	x	x	x	x
SNMP, Web and Ethernet Craft Access	x	x	x	x	x	x	x	x	x
Single Image Firmware	x	x	x	x	x	x	x	x	x
Supports XM3-HP	x	x	x	x	x	x	x	x	x
Single Processor Design 1-IP, 2-IP	x	x	x	x	x	x	x	x	x
Harness Installation and RF Level Indicators	x	x	x	x	x	x	x	x	x
Max. Number of Battery Strings Monitored	4, Requires SAG-4 option	2	4	4, Requires SAG-4 option	4	2	4	2	4
External Equipment Monitoring and Control	x	x	x	x	x	x	x	x	x
Multiple PS and Generator (AlphaBus)	x	x	x	x	x		x		x
Supports IPv6 Addressing	x	x	x	x	x	x	x	x	x
Constellation and Microreflection Diagrams	x	x	x	x	x	x	x	x	x

Table 1-5, Comparative Features, AlphaNet Series Communication Modules

1.0 Introduction, Continued

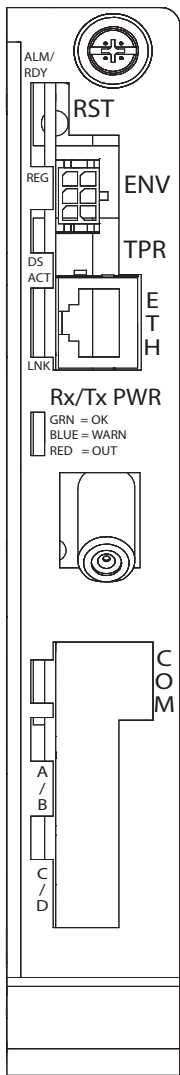

AlphaNet DPM or IDH4L

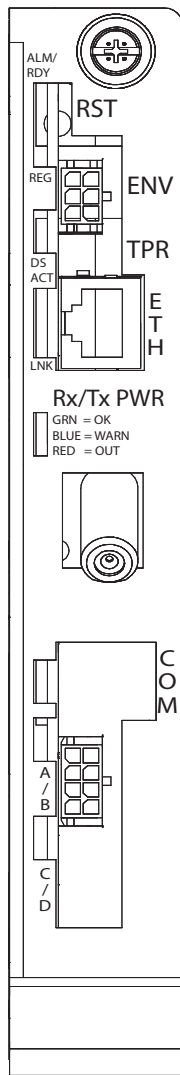

AlphaNet DSM3

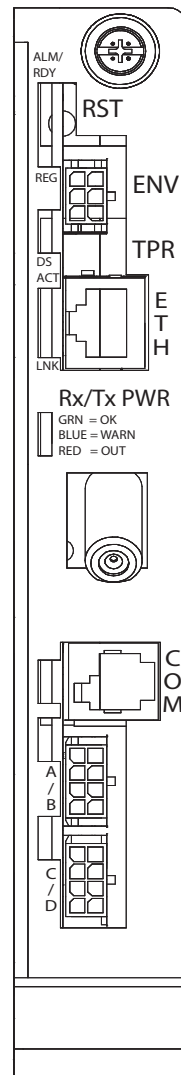

AlphaNet DSM3x or IDH4x

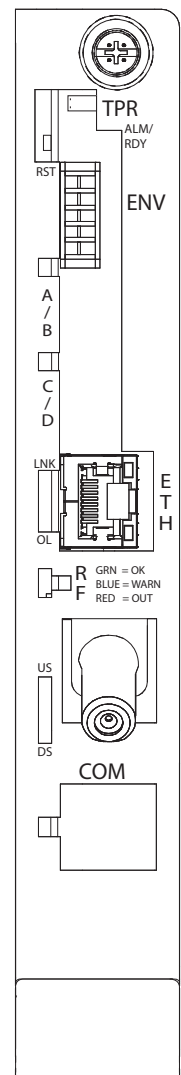

AlphaNet DM3

Fig. 1-17, AlphaNet Series Transponders

2.0 Installation

2.1 Installation Procedure

The Alpha XM3-HP CableUPS can be shelf-mounted within a variety of Alpha enclosures and secured with an internal tamper-resistant security screw kit. The installer must read and follow all safety instructions starting on page 9 and the preliminary inspection below prior to installation of the power supply.



CAUTION!

Read the Safety Precautions, Utility Power Connection Notes and Grounding Connection Notes (pages 9-15) before installing the power supply.

2.1.1 Pre-installation Inspection

1. Remove the power supply from the shipping container. Confirm the power supply, including the Precision Temperature Sensor and all other ordered options, are included.
2. During shipping, components might shift. Carefully inspect the power supply and other contents for possible shipping-related failures, such as loosened or damaged connectors. If any items are damaged or missing, contact Alpha Technologies or the shipping company immediately. Most shipping companies have a short claim period.
3. Do not attempt to install a power supply without first passing a complete pre-installation inspection.



NOTICE:

Use the original shipping container if the power supply needs to be returned for service. If the original container is not available, make sure the unit is well packed with at least three inches of shock-absorbing material to prevent shipping damage. Use single shipment packaging (Alpha p/n 966-639-10 or 966-640-10) to return ship a damaged power supply. If necessary, palletize shipment to protect power supply.



CAUTION!

Do not use popcorn-type material. Alpha Technologies is not responsible for damage caused by improper packaging of returned units.

2.1.2 Internal Security Screw Kit Installation

The XM3-HP Power Supply security screw kit provides the hardware for securing the power supply to its enclosure. The security key for the included security screw is *NOT* in the installation kit and must be purchased separately from Alpha. The customer may supply their own tamper resistant/security fastener if desired.



WARNING! ELECTRICAL HAZARD

- Only qualified service personnel should perform this procedure.
- Use **EXTREME CAUTION** when drilling into the enclosure. Clear all equipment, wiring, and batteries from the area into which you are drilling.
- Lead-acid batteries contain dangerous voltages, currents and corrosive material.



NOTICE:

- **This security enhancement is available on the XM3-HP with a manufacturing code of 2013 and newer.**
- Enclosure and power supply unit may differ slightly from the figures. Use as reference only.

Required Materials:

- Security Screw Kit, p/n 746-316-20
- Alpha-01 Security Key, p/n 647-188-10
- 3/8" Hand Drill
- 13/32" (#Y) Drill Bit
- Center Punch
- 3/8" Socket and Torque Wrench

2.0 Installation, Continued

Kit Includes:

- A. 3/4" x 1/4" Aluminum Spacer, p/n 640-174-10
- B. 1-1/2" SS Flat Washer, p/n 633-015-12
- C. 5/16-18 X 1" SS Security Screw, p/n 647-189-12

(* – Customer may supply their own tamper resistant/ security fastener. If so, do not use kit supplied screw.

Not Included (w/ Internal Security Screw Kit):

- D. Alpha 01 Security Screw Key, p/n 647-188-10

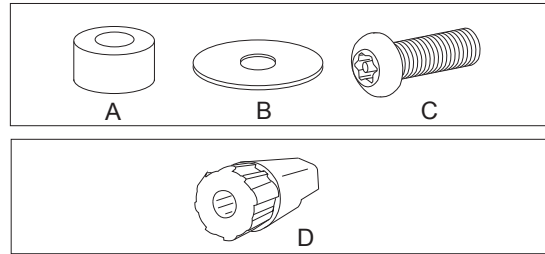

Fig. 2-1, Required Materials

Installation Procedure:

1. Locate the security screw mounting location on the XM3-HP power supply (see Fig. 2-2).
2. Mark the location of the XM3-HP security screw hole on the enclosure shelf.
3. Using the 13/32" drill bit, drill the hole for the security screw. Remove all metal shavings from the enclosures.
4. Position the 1/4" aluminum spacer over the hole (use the center punch to locate the spacer directly over the hole).
5. Position the XM3-HP power supply with the security hole over the drilled hole and spacer (use the center punch to hold the spacer in place while situating the power supply) (see Fig. 2-3).
6. Install the 5/16-18 X 1" SS Security Screw and 1-1/2" SS Flat Washer from the underside of the shelf. If installing the supplied 5/16-18 X 1" SS Security Screw, torque to 26 ft-lbs (35.2 Nm). If installing a different security screw, follow the manufacturer's recommendations for torque.

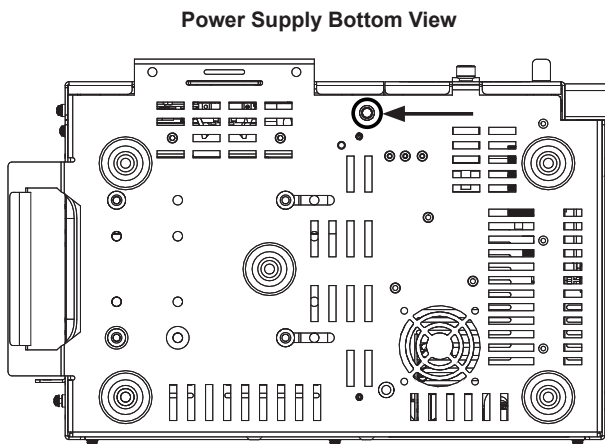

Fig. 2-2, Security Screw Mounting Location

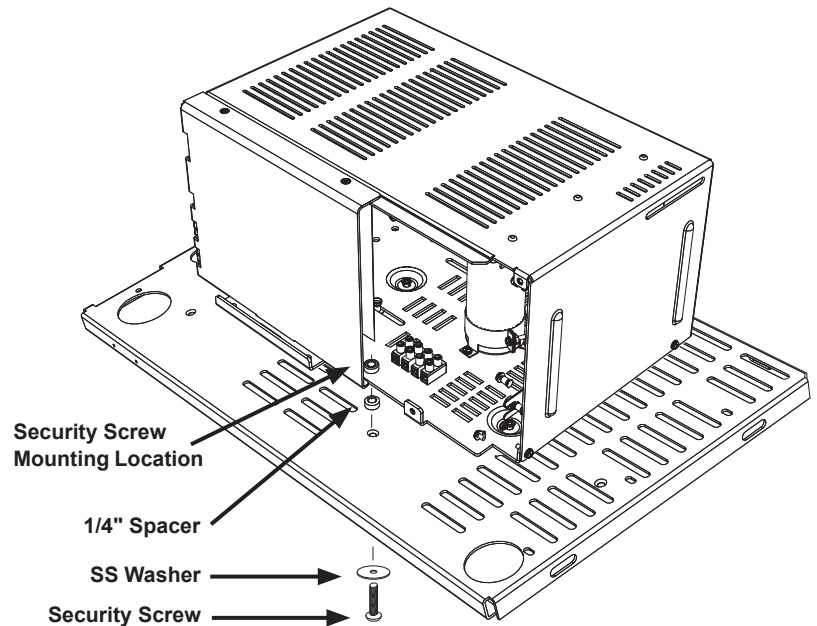

Fig. 2-3, Power Supply/Enclosure Shelf Security Screw Stack Up

2.0 Installation, Continued

2.2 XM3-HP Start-Up Procedure

2.2.1 Parts and Connections

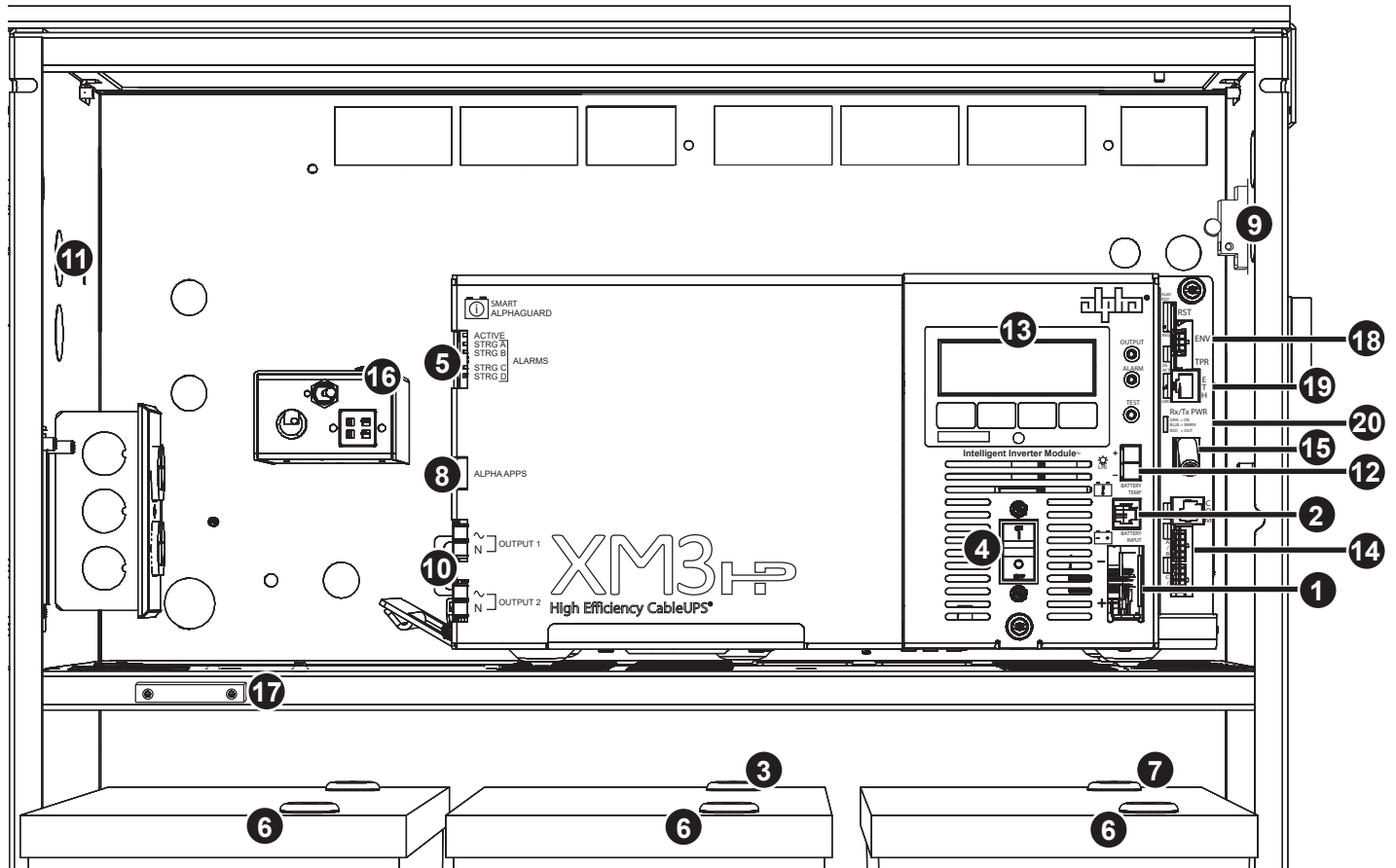

Fig. 2-4, Installation of XM3-HP

- | | |
|---|---|
| 1 Battery Connector to Inverter | 11 Local Remote Indicator (LRI) Mounting Location |
| 2 Precision Temperature Sensor (PTS) | 12 LRI Interface to Inverter |
| 3 Negative Terminal to Center Battery and PTS | 13 Smart Display |
| 4 Battery Breaker | 14 Transponder Battery Sense Harness Connector |
| 5 Smart AlphaGuard Harness | 15 RF Connector to Transponder |
| 6 Positive Battery Terminals to SAG (3, Red) | 16 Service Power Inserter (SPI) |
| 7 Negative Battery Terminal (1, Black) | 17 Alarm Intrusion Tamper Switch |
| 8 APPS Card | 18 Transponder Tamper Switch Connector |
| 9 Grounded Surge Protector | 19 Ethernet (Web Page Interface) |
| 10 AlphaDOC Dual Output Connectors | 20 Tri-color LED Tx/Rx Power Levels |

WARNING! ELECTRICAL HAZARD

Verify battery voltage, cable color, connection and polarity are correct before proceeding.

2.0 Installation, Continued

2.2.2 Battery Installation Options and Wiring Diagram

Convection airflow battery cooling relies on proper spacing of batteries installed in the enclosure. Consistent spacing is achieved by the use of Alpha's Battery Spacer clips. These easy-to-install clips snap over the tops of AlphaCell batteries allowing for optimal airflow. For domestic applications, use one battery clip per 36V battery string for optimal spacing. For international applications, use two clips per 36V battery string (See Fig. 2-5).

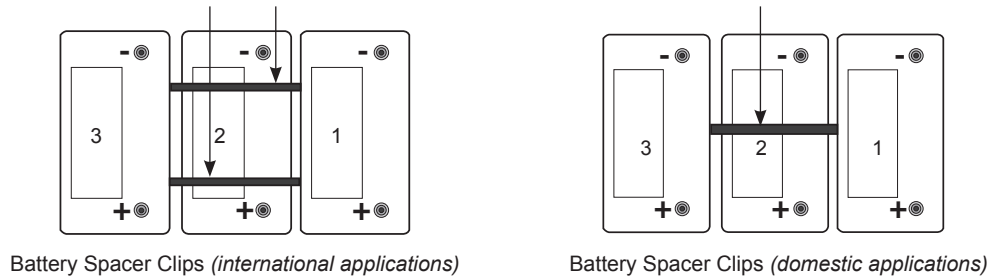

Fig. 2-5, Placement of Battery Spacer Clips (for domestic and international 36V battery strings)

Load batteries into cabinet with the positive terminals (+) facing forward. Battery strings are lettered A through D; batteries are numbered 1 through 3, from right to left.

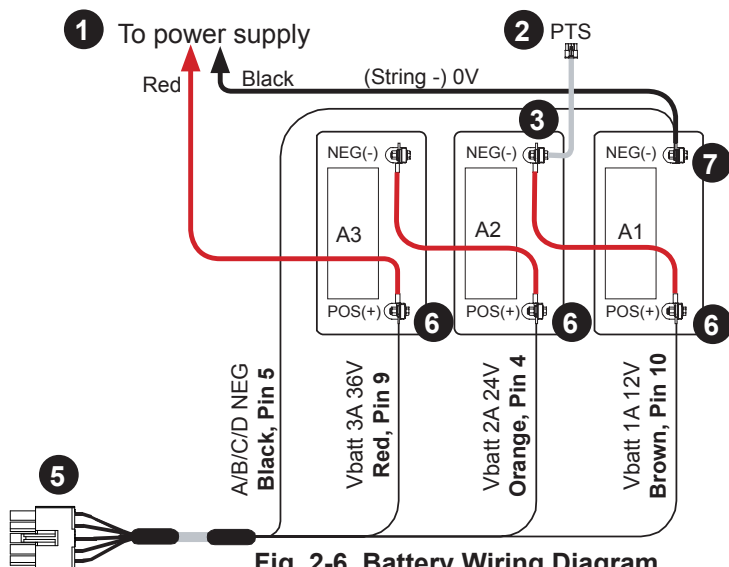

Fig. 2-6, Battery Wiring Diagram (w/ embedded SAG option depicted)



Fig. 2-7, Precision Temperature Sensor (PTS), p/n 746-331-20

AlphaGuard (external) — use Battery Harness, p/n 875-090-32

Upgrade existing external AlphaGuard to Smart AlphaGuard — use Retrofit Cable, p/n:
 875-910-20 for one string
 875-910-21 for two strings
 875-910-22 for three strings
 875-910-23 for four strings

Smart AlphaGuard (Embedded) — use Battery Harness, p/n:
 875-848-20 for one string
 875-848-21 for two strings
 875-848-22 for three strings
 875-848-23 for four strings

Adapt Smart AlphaGuard harness to legacy DM3X/DSM3/DSM3x connector — use Adaptor Cable, p/n 876-003-20

DSM3 / IDH4 (1 battery string) — use Battery Sense Harness, p/n 874-842-21 (Not required if SAG is installed with its sense harness).
 DSM3 / IDH4x (2 battery strings) — use Battery Sense Harness, p/n 874-842-28 (Not required if SAG is installed with its sense harness).
 DSM3x / IDH4x (3 battery strings) — use Battery Sense Harnesses, p/n 874-842-21 and 874-842-28 (Not required if SAG is installed with its sense harness).
 DSM3x / IDH4x (4 battery strings) — use Battery Sense Harness, p/n 874-842-20 and 874-842-28 (Not required if SAG is installed with its sense harness).

2.0 Installation, Continued

18V4 Battery Wiring

The AlphaCell XTV 18V4 battery is a lead acid battery that facilitates an oxygen recombination cycle and each battery is comprised of nine 2V cells internally connected in series to provide 18 volts.

The battery system is a group of individual batteries connected in a series string to provide a higher voltage system. In Fig. 2-8, two batteries are connected in series to provide string with a nominal voltage of 36V @ 55Ah.

✓ **NOTICE:**

Each AlphaCell XTV 18V4 is shipped with a jumper cable to be used when connecting multiple batteries.

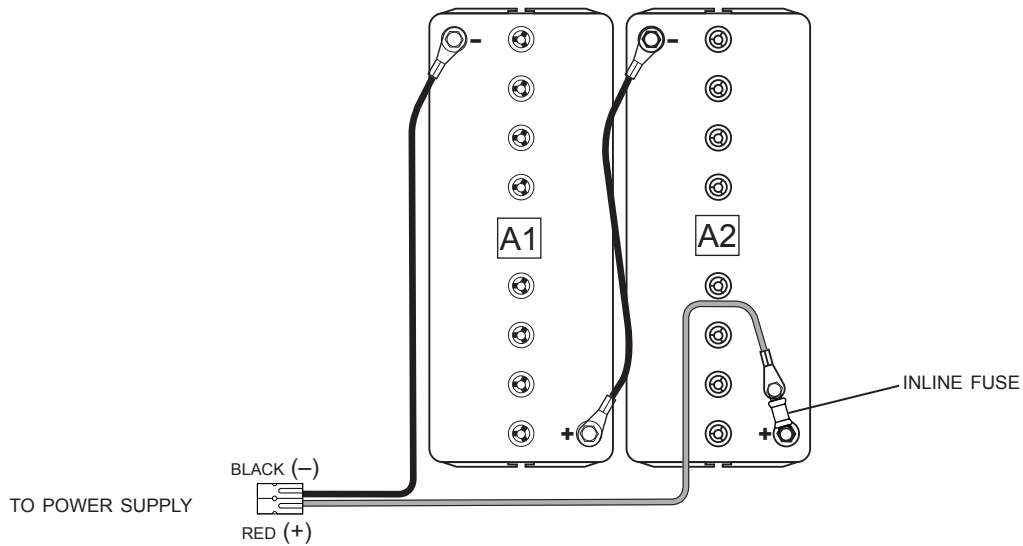

Fig. 2-8, AlphaCell 18v4 Two Battery Configuration (36V, 55Ah)

2.0 Installation, Continued

Battery strings connected in series create a system whose voltage equals the sum of the batteries, while the capacity (in Ah) remains that of a single battery. In Fig. 2-9, batteries A1 and B1 (connected in parallel) are in series with batteries A2 and B2 (connected in parallel) to provide a nominal 36V at 110Ah capacity.



WARNING! ELECTRICAL HAZARD

Install an inline fuse on the terminals indicated below (*Fuse upgrade kit Alpha p/n 744-863-20-002*). In the event a replacement fuse is needed, contact Alpha Technologies to order Alpha p/n 460-191-10.

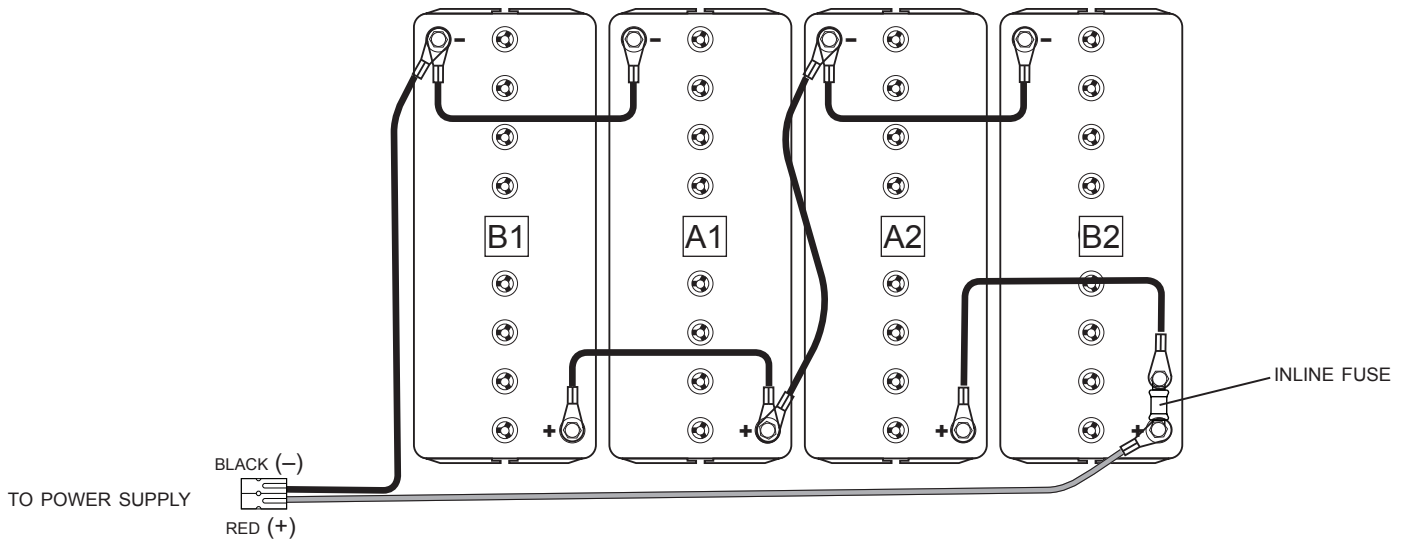

Fig. 2-9, AlphaCell 18v4 Four Battery Configuration (36V, 110Ah Capacity)

2.0 Installation, Continued

AlphaCell 18v4 8-battery (dual tray) wiring and battery sense wiring.

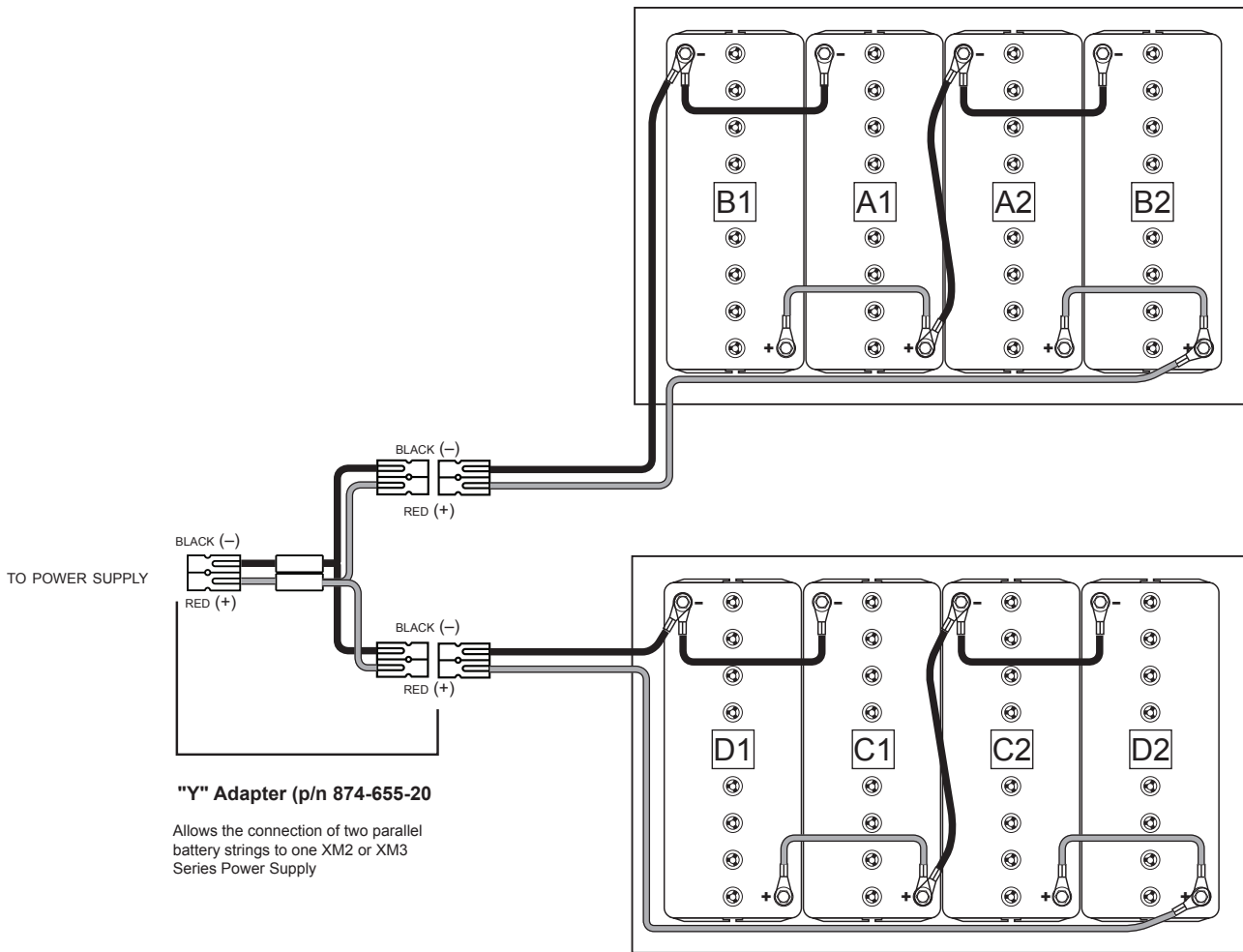

Fig. 2-10, Wiring diagram, 8-battery Parallel Configuration



NOTICE:

Each AlphaCell XTV 18V4 is shipped with a jumper cable to be used in dual string configurations.

2.0 Installation, Continued

AlphaCell 18v4 Battery sense wiring as part of a new installation.

NOTICE:

The AlphaCell XTV 18V4 does not support the Smart AlphaGuard (SAG) battery charge management function. The SAG functionality will be disabled in XM3 Power supplies configured with Platform 14 firmware code. To avoid possible alarms, the SAG should be disconnected and the sense harness replaced with a standard DSM harness connected to the Battery A/B, C/D connector on the DM3X. If the SAG is still installed, selecting the 18V battery will result in a SAG Compatibility alarm.

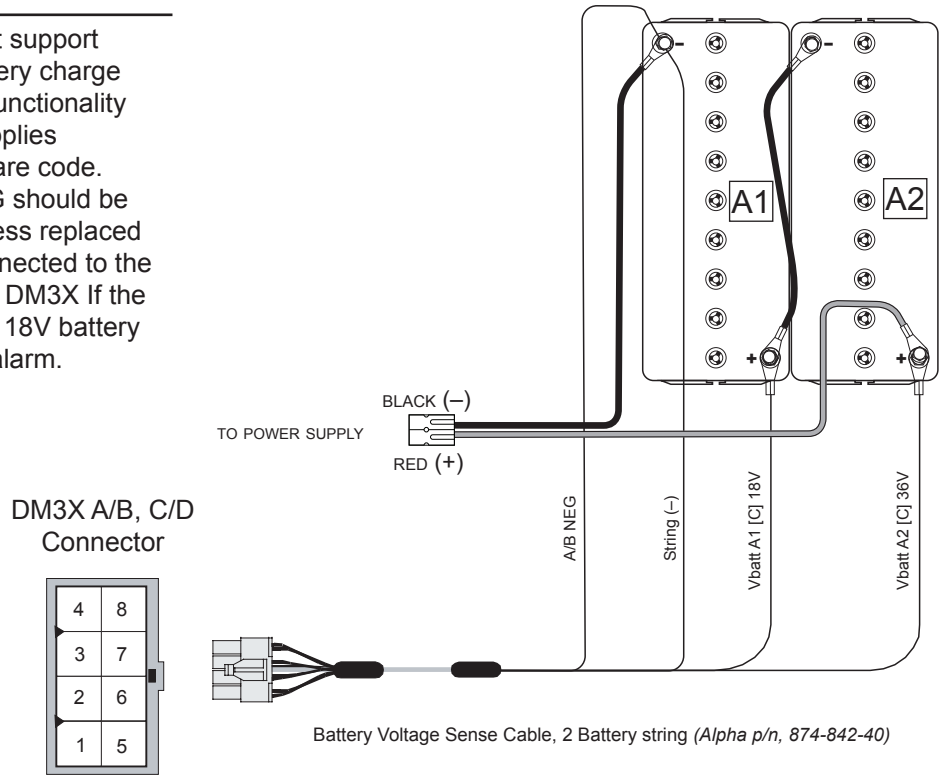

Fig. 2-11, Battery Sense Wiring, 36V, 2 Battery Configuration

NOTICE:

Each AlphaCell XTV 18V4 is shipped with a jumper cable to be used in dual string configurations.

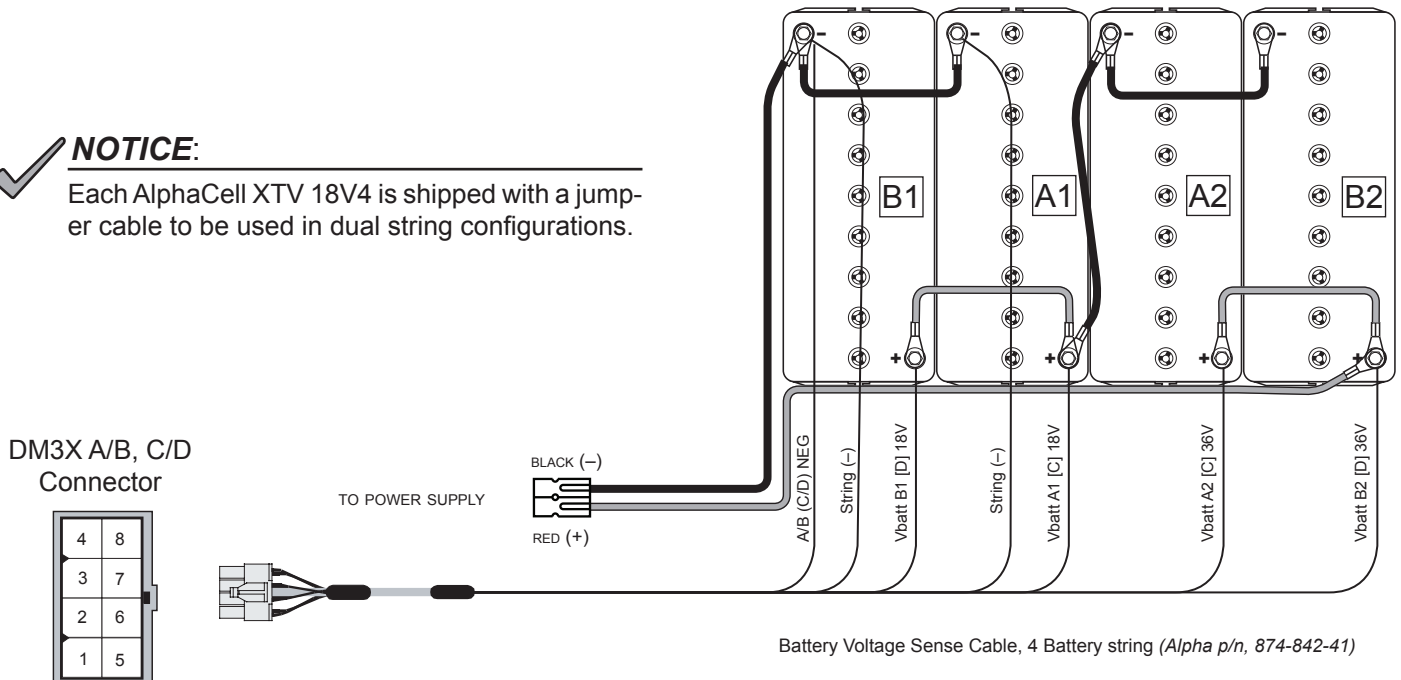

Fig. 2-12, Battery Sense Wiring, 36V, 4 Battery Configuration

2.0 Installation, Continued

AlphaCell 18v4 Battery sense wiring as part of a retrofit installation.

✓ **NOTICE:**

The AlphaCell XTV 18V4 does not support the Smart AlphaGuard (SAG) battery charge management function. The SAG functionality will be disabled in XM3 Power supplies configured with Platform 14 firmware code. To avoid possible alarms, the SAG should be disconnected and the sense harness replaced with a standard DSM harness connected to the Battery A/B, C/D connector on the DM3X. If the SAG is still installed, selecting the 18V battery will result in a SAG Compatibility alarm.

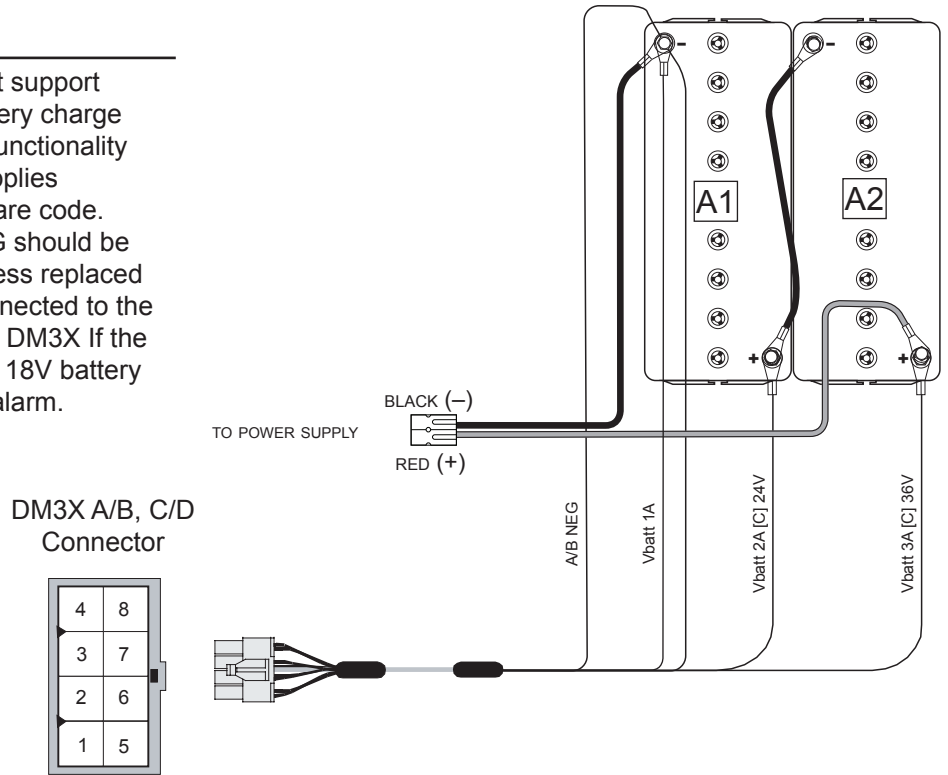

Fig. 2-13, Battery Sense Wiring, 36V, 2 Battery Configuration

✓ **NOTICE:**

Each AlphaCell XTV 18V4 is shipped with a jumper cable to be used in dual string configurations.

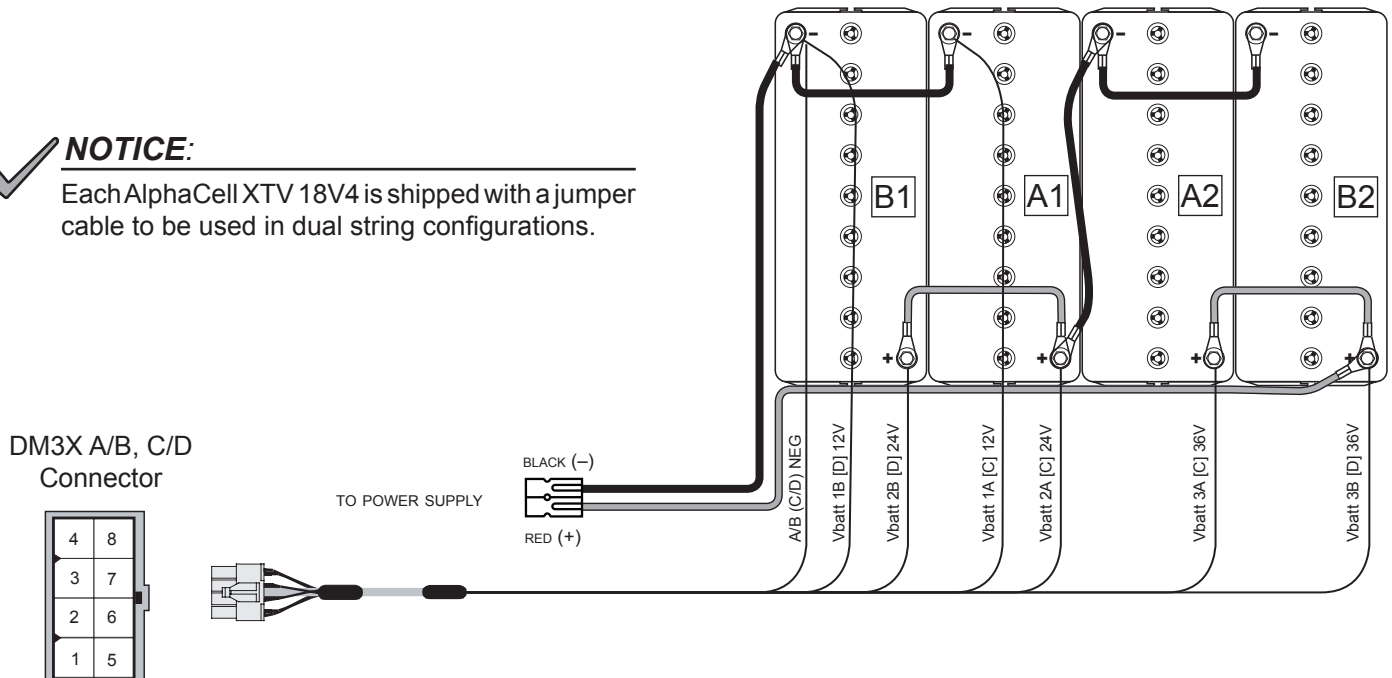

Fig. 2-14, Battery Sense Wiring, 36V, 4 Battery Configuration

2.0 Installation, Continued

Threaded Insert Terminals



CAUTION!

Threaded insert terminals require the use of 3/4" (19mm) bolts with the exception of 18V4 batteries which require the use of M6 x 12mm bolts. The use of 1" (25.4mm) bolts will seriously damage the battery. The only exception is the terminal with the large spacer for the in-line fuse link. Apply NO-OX grease on all exposed connections.

Torque all nuts and bolts to 110in-lbs (12.43N-m).

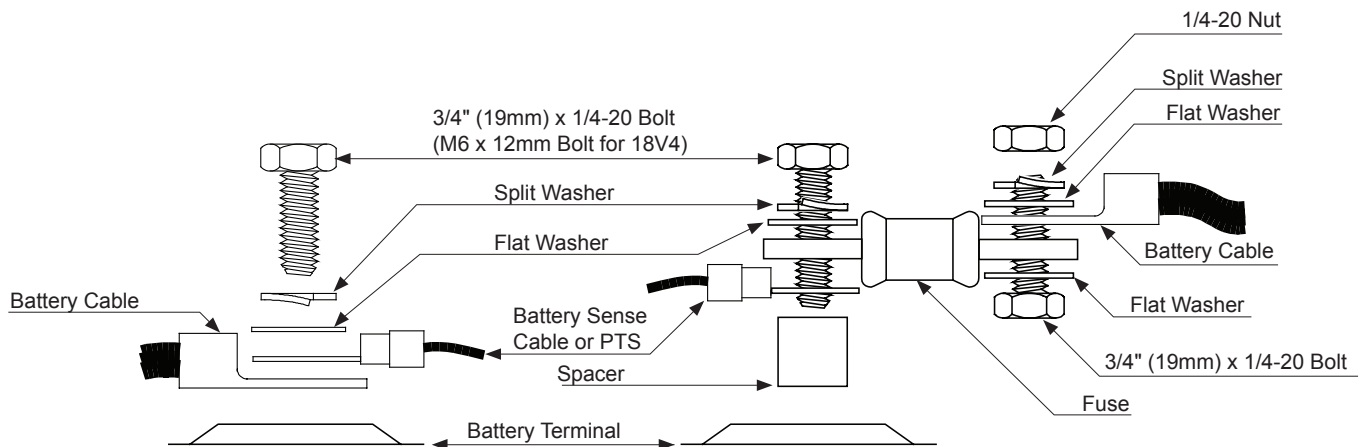

Fig. 2-15, Battery Terminal Bolt Stack-up

Fig. 2-16, Fuse Bolt Stack-up

2.2.3 120/240V Configuration Procedure



NOTICE:

This procedure is for the XM3-918D-HP only.

Procedure:

1. Remove the Inverter Module to access the Transformer Harness (see Fig. 2-17).
2. Connect the appropriate connector to the Transformer Harness. For the 120V configuration, connect the end with two wires. For the 240V configuration, connect the end with only one wire (see Fig. 2-18).
3. Connect the correct power cord to the power supply (see Fig. 2-19)

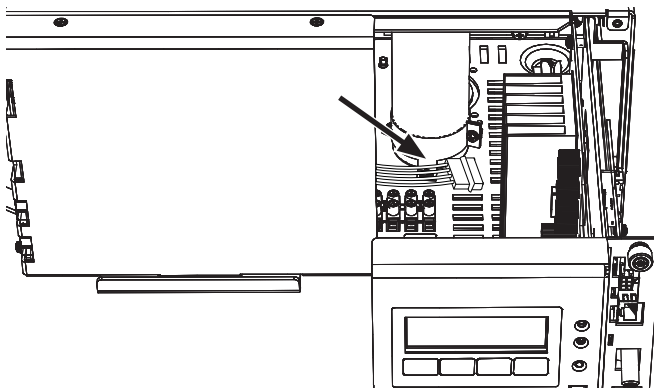

Fig. 2-17, Transformer Harness

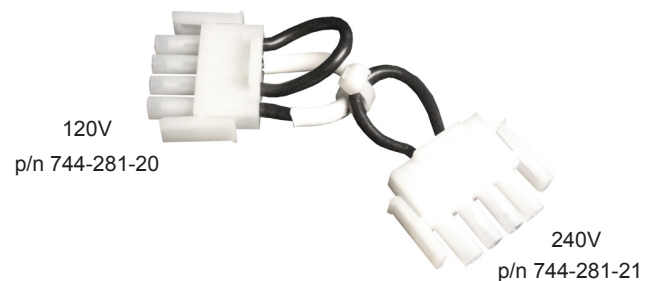

Fig. 2-18, 120/240V Connector

2.0 Installation, Continued

- Upon start up, the Input Voltage Setting screen will appear. Select correct voltage to proceed (see **Section 3.3, Smart Display Menus**). The Input Voltage Setting screen displays for five minutes before reverting to the previous settings.



CAUTION!

- If 240V is connected to the power supply input when the transformer has the 120V plug installed, the input circuit breaker will trip.
- If the 120V setting is selected when the input is 240V, the Input Failure alarm will activate and the power supply will transfer to inverter if batteries are connected.
- If the incorrect voltage setting is selected, change the settings by either cycling the power again or accessing the Input Voltage Setting in the Power Configuration menu.



NOTICE:

An XM3 running firmware version 1.14.0 or later will display the Input Voltage and Current in the upper left of the screen.

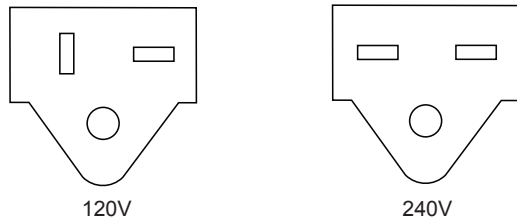

Fig. 2-19, Line Cord Plugs

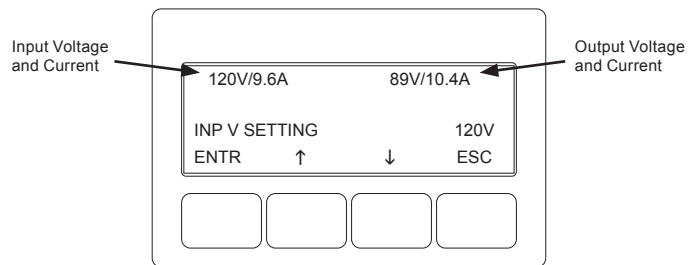

Fig. 2-20, Input Voltage Setting Screen

2.2.4 63/89VAC Output Voltage Reconfiguration Procedure



WARNING! ELECTRICAL HAZARD

Remove all sources of power to unit before performing the following procedure.

Tools Required:

Small flat-blade screwdriver

Procedure:

- To access Output Voltage Terminal, remove the Inverter Module (see Fig. 2-21).
- Loosen the terminal screw and move the Output Voltage Wire to the desired output voltage position on the Output Voltage Terminal (see Fig. 2-22).
- Torque the terminal screw to 7in-lbs (0.79N-m) to secure the Output Voltage Wire.
- Replace the Inverter Module.

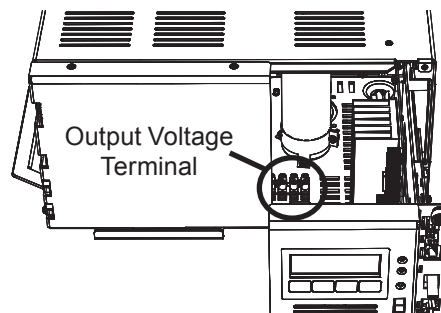

Fig. 2-21, Voltage Terminal Location behind Inverter Module

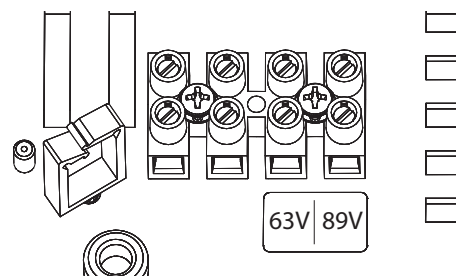

Fig. 2-22, Voltage Wire Position

2.2.5 Optional Smart AlphaGuard and Alpha APPS Installation



WARNING! ELECTRICAL HAZARD

Remove all sources of power to unit before performing the following procedure.

Tools required:

#2 Phillips screwdriver

Procedure:

1. Remove the three fasteners securing the front panel (see Fig. 2-23).

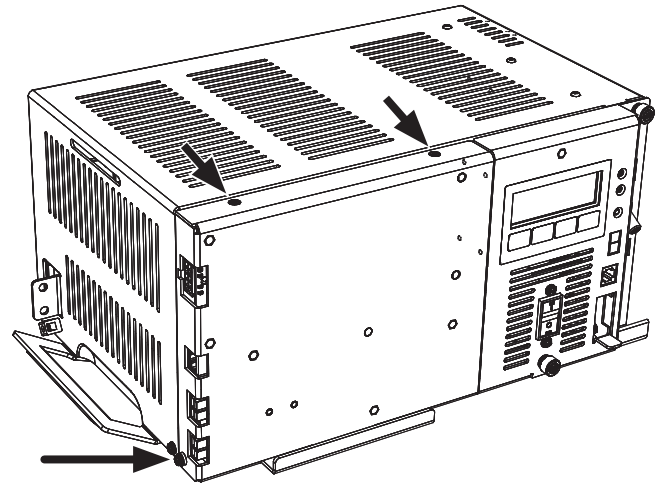

Fig. 2-23, Front Panel Fastener Locations

2. With the front panel open, install the APPS card by pressing it firmly onto the standoff (A) and fastening the 6-32 screw (B) (see Fig. 2-24).
3. Connect the ribbon cable (C) and ensure the locking clips are closed.

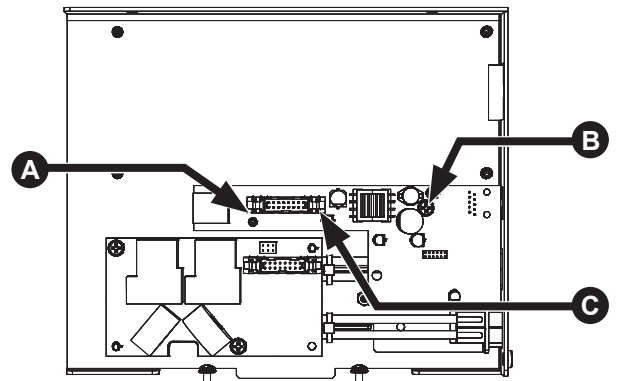

Fig. 2-24, APPS Card Standoff, Screw and Ribbon Cable Locations

4. Install the SAG card by pressing it firmly onto the two standoffs (D) and fastening the two 6-32 screws (E) (see Fig. 2-25).
5. Connect the ribbon cable (F) and ensure the locking clips are closed.
6. Reinstall the front panel and secure with the fasteners removed in Step 1.

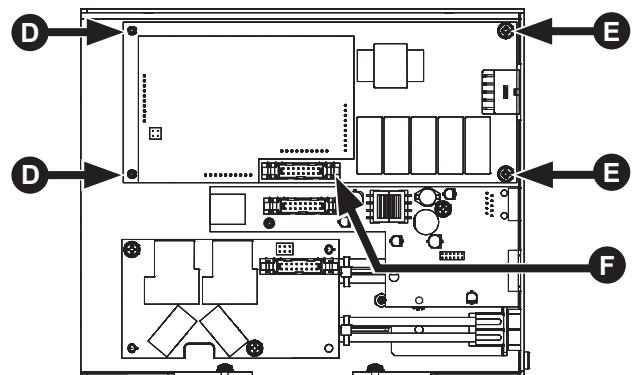

Fig. 2-25, SAG Card Standoffs, Screws and Ribbon Cable Locations

2.0 Installation, Continued

Procedure:

7. Connect the SPI (16) to the AlphaDOC Dual Output Connector (10) (see Fig. 2-26).
8. Connect the SAG Harness to the SAG Connection (5) (see Fig. 2-26).

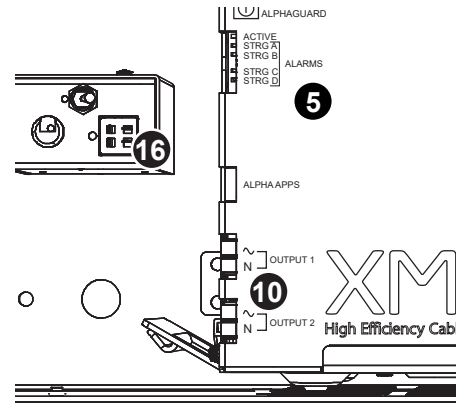
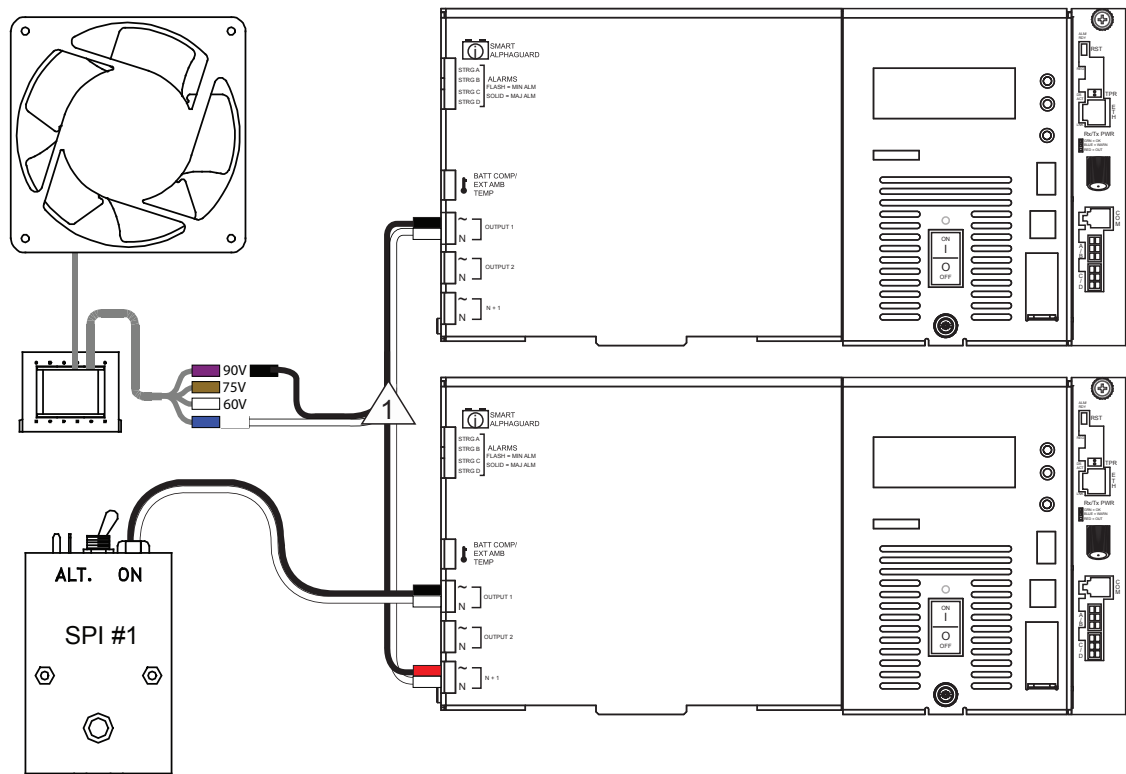

Fig. 2-26, SPI, AlphaDOC and SAG Harness Connections

2.2.6 Optional N+1 Configurations

Because the N+1 option provides a second output, the Intelligent CableUPS can function as an N+1 redundant supply system. The N+1 option also provides programmable current limits for two output channels, which protects system components by shutting down the load during overcurrent and short circuit conditions. Adding a DOC with N+1 to a secondary power supply enables both power supplies to be connected in a “dual redundancy” configuration to protect two critical loads.



1 Wire Kit (Alpha P/N: 875-994-20)

Fig. 2-27, N+1 Configuration

2.0 Installation, Continued

The N+1 ports are used in redundant system configurations where multiple power supplies are housed in a single enclosure. In the event of a power supply failure, a redundant power supply (with an optional DOC with N+1 board installed) is automatically switched into service with approximately a 8ms delay. This feature is part of the DOC with N+1 option.

This provision also protects system components by shutting down the load during overcurrent and short circuit conditions. Adding a DOC with N+1 in the secondary power supply enables both power supplies to be connected in a “dual redundant” configuration so the system can protect two critical loads (see Fig. 2-28).

NOTICE:

The N+1 unit and the primary unit cannot be loaded over 50% of rated capacity when configured as shown below.

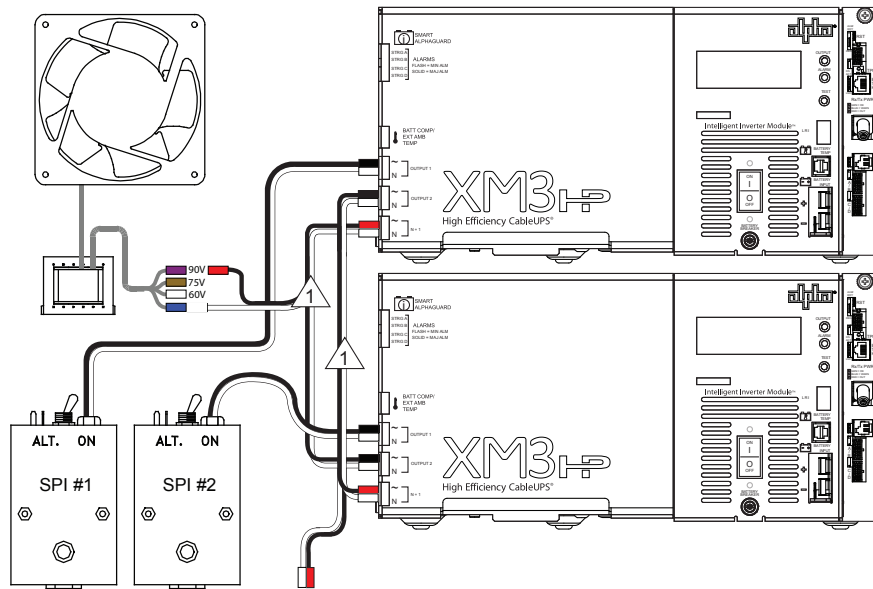

1 Wire Kit (Alpha P/N: 875-994-20)

Fig. 2-28, Dual Redundancy N+1 Configuration

When the power supply is in N+1 operation, the active alarm menu screen will display (see Figure 2-29). Additionally, the Output Voltage and Output Current display in the upper right hand corner of the Smart Display will show 0 Volts and a value for the Output Current Amperage (e.g. 0V/10.8A). This Output Current Amperage is the sum of output terminals. By pressing the softkey below the PWR menu the Active Alarms menu will display (see Figure 2-30).

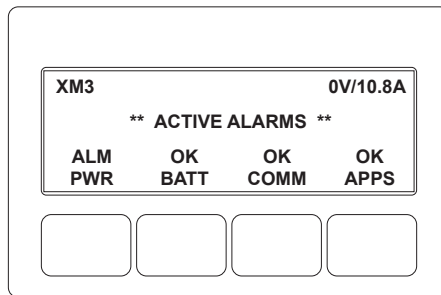

Fig. 2-29, Active Alarm Screen

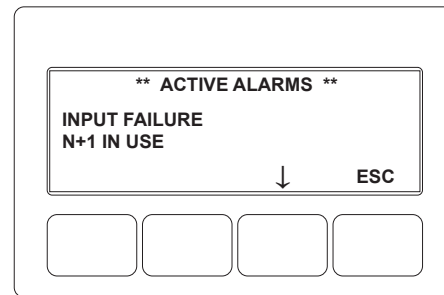

Fig. 2-30, N+1 In Use Alarm Screen

NOTICE:

When N+1 is in use, the displayed Output Current will not agree with the Output Current CIB on the remote status monitoring web-page, which will show 0 Volts for Output Voltage and 0 Amps for the Output Current. However, the Output Current displayed on the Smart Display will be correct for the output terminals.

2.0 Installation, Continued

2.2.7 Communications DOCSIS Status Monitoring

DOCSIS Status Monitor Front Panel Connections

1. Connect Battery Sense Wire Harness to the A/B, C/D connection points (14) on the transponder. The connection (14) is not required for individual battery monitoring if the Smart AlphaGuard option is deployed. For XM3 units with the Smart AlphaGuard option, connect the Battery Harness (5) to the AlphaGuard connection located on the left side of the XM3 power supply, see Fig. 2-4.
2. Connect Tamper Switch Wire Harness to the TPR Connector (18).
3. Connect the RF drop (15) and make front panel connections as shown below for the DSM3 or IDH4. The DOCSIS specification for downstream power level is +/-15 dBmV. However, for optimal performance, set the level as close to 0 dBmV as possible.

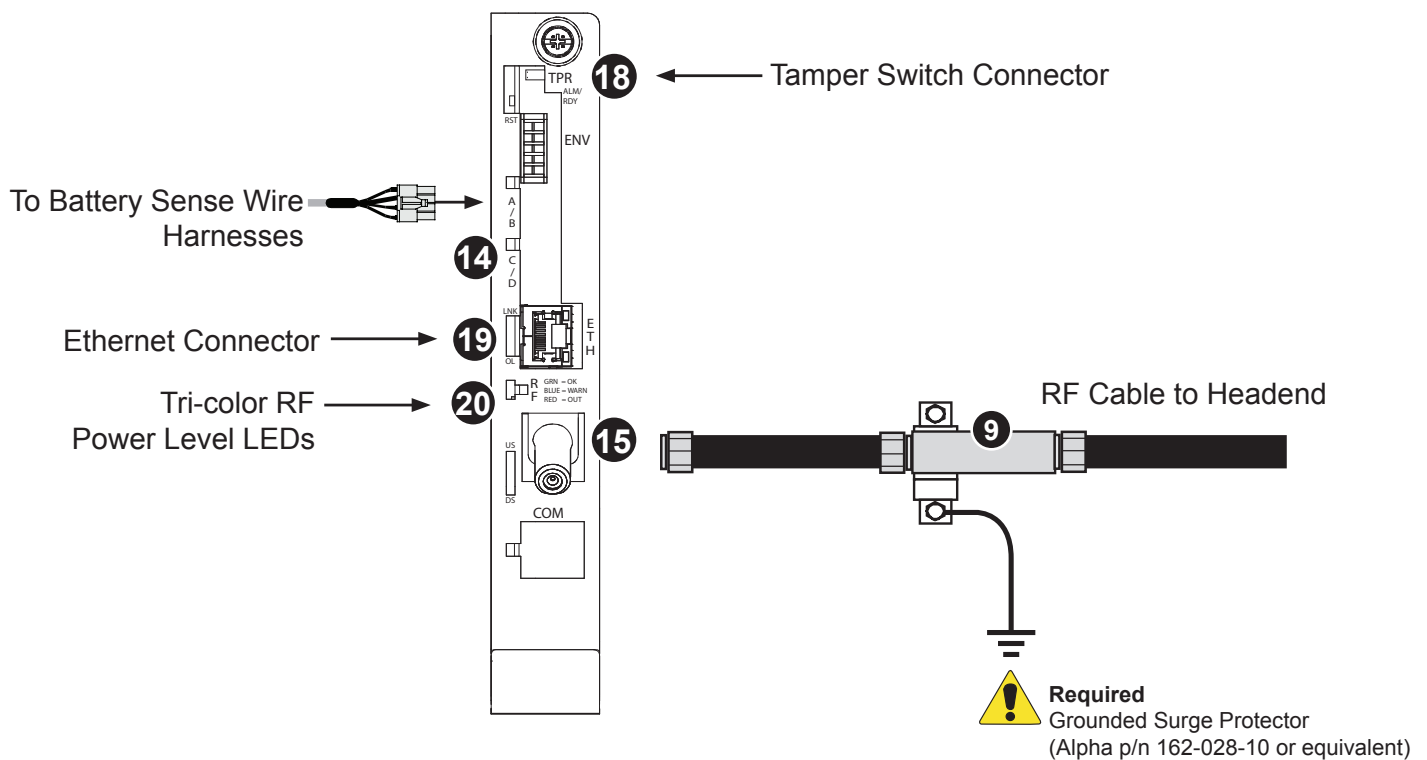

Fig. 2-31, DOCSIS Status Monitor Front Panel Connections

2.0 Installation, Continued

LED Status Verification

Verify the DSM3/IDH4 LEDs behavior is as follows:

		LEDs and Indications (20)				
Step	Communications State	ALM/RDY	Downstream (DS)	Registration (REG)	Rx/Tx Power	Communications (COM)
1	Transponder Initializing/Searching for Downstream DOCSIS channel	Flashing (Green)	Flashing	OFF	OFF	Flashing
2	DOCSIS Channel locked - Completing upstream and network registration	Flashing (Green)	ON	Flashing	ON (Green)	Flashing
3	Online - Registration Complete	Flashing (Green)	ON	ON	ON (Green)	Flashing
4	DSM3 Series fully functional	Flashing (Green)	ON	ON	ON (Green)	Bursts when Communicating

Refer to Step 4 in the above table for normal LED behavior when the DSM3 / IDH4 is fully functional.

- Blue Rx/Tx Power LED indicates Rx/Tx Power at a warning level. Make the necessary RF level adjustments.
- Red Rx/Tx Power LED indicates Rx/Tx Power at an alert level. Make the necessary RF level adjustments.

LED Color	Rx Range (dBmV)	Tx Range (dBmV)
Green	+10 to -10	0 to +50
Blue	+15 to +10 and -10 to -15	+50 to +55
Red	>+15 and <-15	>+55

Table 2-1, DSM3 / IDH4 LEDs Behavior

Verify the DM3 LEDs behavior is as follows:

LEDs and Indications								
Step	Communications State	ALM/RDY	Downstream (DS)	Upstream (US)	Rx / Tx Power	ONLINE (OL)	Communications (COM)	Link (LNK)
1	Transponder Initializing / Searching for Downstream DOCSIS channel	Flashing (Green)	Flashing	OFF	OFF	OFF	OFF	OFF
2	Downstream channel acquired, service group determination and ranging initialization	Flashing (Green)	ON	Flashing	OFF	OFF	OFF	OFF
3	Online - registration complete	Flashing (Green)	ON	ON	ON (Green)	ON	OFF and ON	OFF
4	DM3.0 Series Transponder fully functional	Flashing (Green)	ON	ON	ON (Green)	ON	Bursts when communicating to multiple power supplies	OFF
5	Laptop Connected (Local)	Flashing (Green)	ON	ON	ON (Green)	Bursts when CPE device communicating	Bursts	ON

Table 2-2, DM3.0 LEDs Behavior

Refer to Step 4 in the above table for normal LED behavior when the DM3 is fully functional.

- Blue Rx/Tx Power LED indicates Rx/Tx Power at a warning level. Make the necessary RF level adjustments.
- Red Rx/Tx Power LED indicates Rx/Tx Power at an alert level. Make the necessary RF level adjustments.

2.0 Installation, Continued

2.2.8 Power Module Configuration and Installation Procedure



NOTICE:

Before applying power, verify power supply rating is matched to AC input utility. Verify a low-resistance ground is installed in accordance with your local electrical regulatory authority.



CAUTION!

Batteries are an important part of the power supply. Properly install and test all batteries, battery connections and battery cables before you connect them to the power supply.

1. Route the Local/Remote Indicator cable down through the opening in the left side of the shelf and back up through the opening in the right side of the shelf and connect.



NOTICE:

For existing LRI installations, use LRI adapter kit, p/n 875-952-20.

2. After wiring battery cable kit, battery sense cables and PTS as shown in **Section 2.2.2, Battery Installation Options and Wiring Diagram**, verify DC breaker is OFF, then connect battery cable to Inverter Module.
3. Connect the Smart AlphaGuard wire harness to Smart AlphaGuard port.
4. Connect Precision Temperature Sensor to Inverter Module.
5. Connect transponder, RF Input cable, and the tamper switch (if installed). Refer to **DOCSIS Status Monitor Front Panel Connections** for communication module connections.
6. For new installations, skip to step 10.
7. For upgrading existing sites, install Service power supply (see Service power supply documents) and remove existing power supply.
8. Thoroughly inspect output connectors for abnormal heating or damaged housing; replace if necessary.
9. Verify SPI (16) switch is in "ALT" position.
10. Connect the SPI (network load) to the Output 1 connector.
11. Connect the second isolated load / auxiliary load (i.e., fan) to the Output 2 connector.
12. Turn on AC breaker (located on enclosure) and verify correct (per unit's nameplate voltage) utility voltage at outlet; if correct, plug in line cord to the utility outlet. For XM3-918D-HP models, the utility voltage may not match the nameplate voltage when switching between 120V and 240V.
13. Turn battery breaker ON. For XM3-918D-HP models, select the Input Voltage Setting by pressing ENTR.
14. Toggle SPI switch to ON.
15. Verify no alarms are present after power up initiation (it may take up to 60 seconds for alarms to clear; APPs alarms may take longer). Alarms may be verified on the LCD display or Alarm LED.

2.0 Installation, Continued

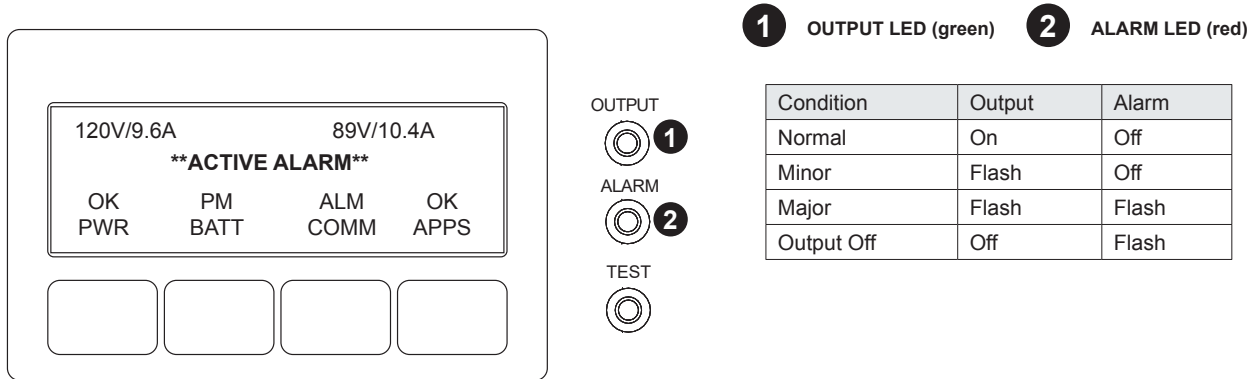

Fig. 2-32, Active Alarm Table

16. If alarms do not clear after 60 seconds, press the menu key with ALM indicated above it to see the ACTIVE ALARM list for the selected key.
17. Press UP or DOWN to select the alarm of interest.
18. Press ENTR to select the alarm and display diagnostic information. Press ESC to return to the alarm list.
19. Enter Battery Type (or parameters) and number of battery strings. Battery type entries can be made on the LCD.
20. Enter the battery DATE code and the MHOs (conductance) readings. Battery date and MHOs entries can be made on the LCD (see Figs. 2-33 and 2-34).

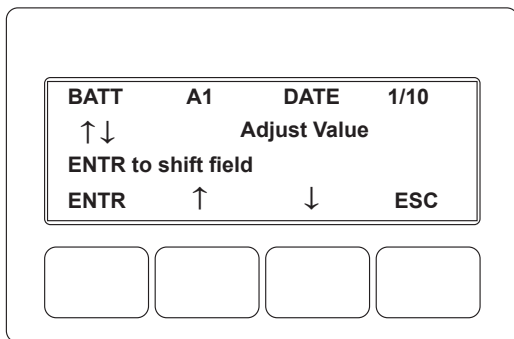

Fig. 2-33, Enter Battery Date Code

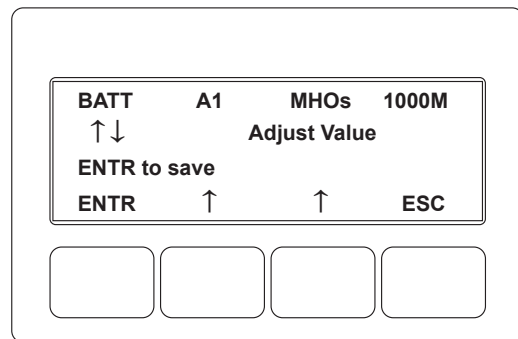

Fig. 2-34, Enter Battery MHOs Reading

✓ NOTICE:

Battery MHOs and Date Code can only be set after DOCSIS transponder has registered with CMTS. Please wait 3 minutes after power up to enter Battery MHOs measurements.

2.0 Installation, Continued

21. Once the unit is running on line voltage, perform a Self Test by pressing and holding the test button for 1-2 seconds with a pen (or similar object). Wait for Self Test completion before proceeding (see **Section 3.1.1, Self Test Operation**).

NOTICE:

If the unit is operating from batteries, the Self Test will not initiate. Check input breaker and input line cord.

22. Perform standby test by shutting off utility breaker and verifying unit goes into standby and supports the load.
23. Re-apply AC power and verify unit goes to Line Mode.

NOTICE:

Two output connectors will be present on the side of the front panel whether or not the optional AlphaDOC is installed. If an AlphaDOC is not installed, the output voltage (Output 1) will be present on both connectors as the connectors are wired in parallel by means of an internal split ("Y") wiring harness. If an optional AlphaDOC is installed, the split wiring harness is replaced with individual wiring for Output 1 and Output 2 (**Secondary loads to be connected to Output 2**).

NOTICE:

The default language is set to English. Unless the XM3 is ordered preset to another language, the language can be changed through the PWR CNFG (Power Configuration) menu. Pressing the PWR (Power) softkey while in the OPERATION NORMAL screen opens the Power Info Menu display (the first letter of the top line will blink indicating it is the active line; shown in orange). Pressing ENTR from this screen opens the PWR CNFG Menu. Scroll down to the SELECT LANGUAGE menu to set to the desired language, see Figure 2-35.

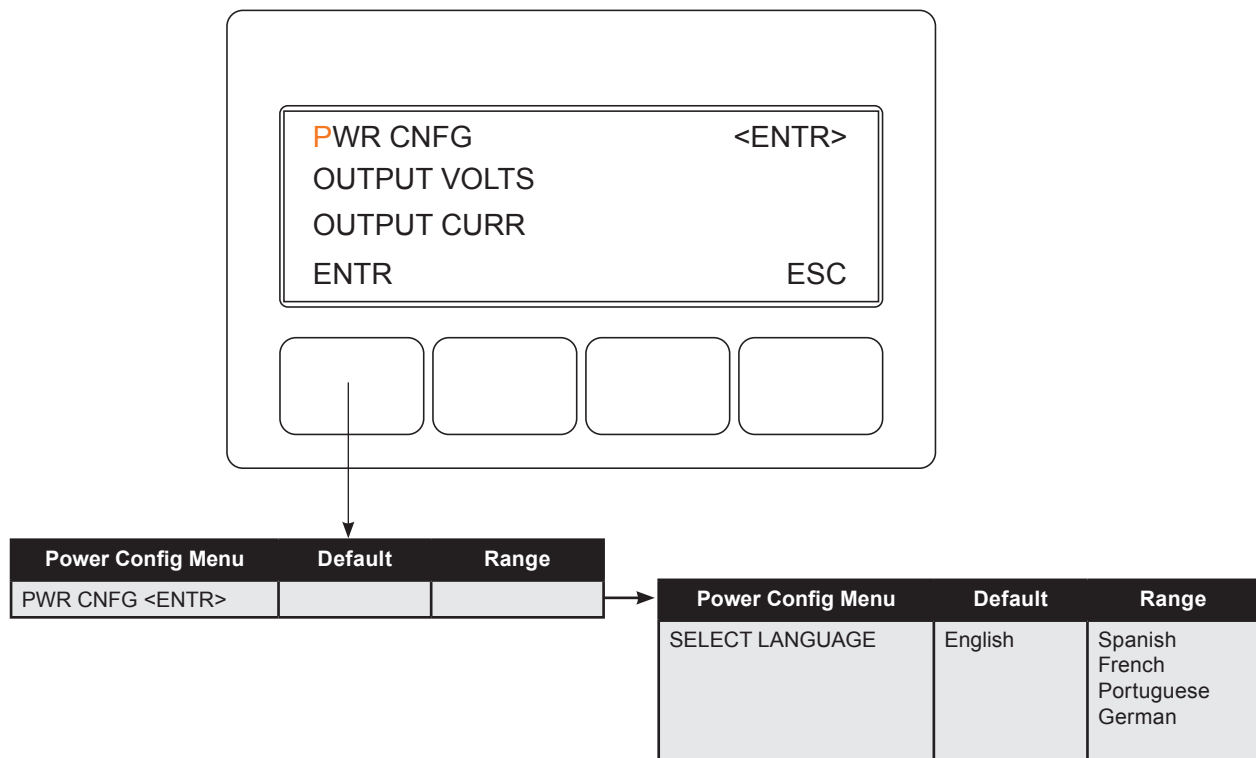

Fig. 2-35, Select Language in PWR CNFG Menu

2.0 Installation, Continued

2.2.9 Local Verification of DOCSIS Transponder

To confirm successful hardware installation before leaving the installation site, verify network connectivity and correct hardware interconnection.

The DS and REG LEDs on the front of the DSM3/IDH4 Series should be ON solid green. This indicates successful registration with the headend. In addition, the RF LED should also be ON solid green indicating proper RF power levels and the ALM/RDY LED should be blinking green for normal operation.

With the DSM3/IDH4 Series used in conjunction with the XM3-HP power supply, network connectivity can be verified via the COMM menu on the XM3 Smart Display. Figure 2-36 provides a list of parameters available on the XM3 Smart Display populated with sample values.

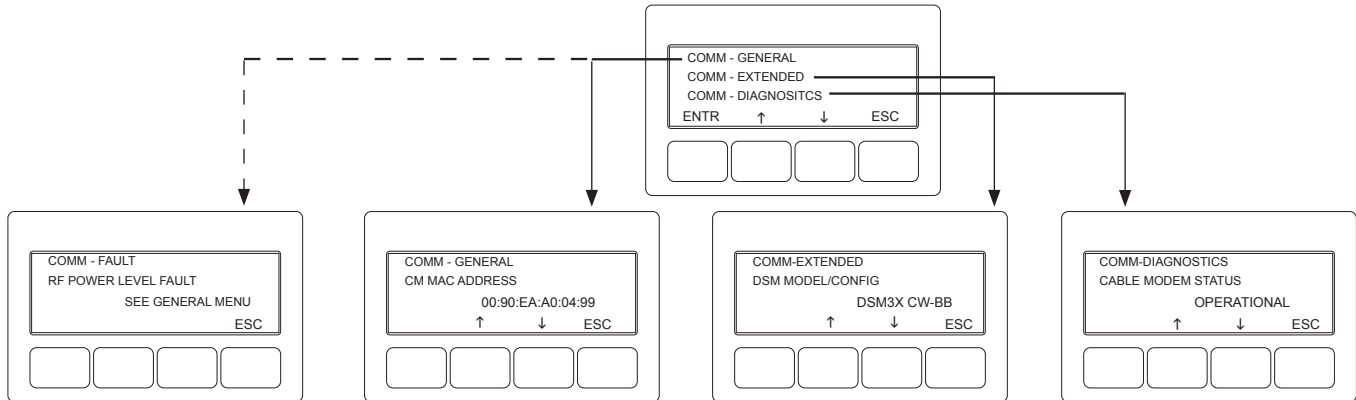

NOTE: COMM-FAULT Menu appears only if there is no RF connection or RF interruption occurs.

COMM GENERAL	
CM MAC ADDRESS	00:90:EA:A0:04:99
CM IP ADDRESS	192.196.203.101
CM IPV6 ADR PREFIX*	2001:123:456:789
CM IPV6 ADR POSTFIX*	111:222:333:3434
CPE MAC ADDRESS**	00:90:EA:A0:04:9A
CPE IP ADDRESS**	192.168.200.100
CM RECEIVE POWER	-12.9dBmV
CM TRANSMIT POWER	34.5dBmV
DOWNSTREAM SNR	33.8dB

* Menu item available if DSM3 is provisioned in IPv6 mode
 ** Menu item available if DSM3 is provisioned in Dual-IP mode

COMM - EXTENDED	
DSM MODEL/CONFIG	DSM3X CW-8B
DSM FIRMWARE VERSION	4.4.9.0_03.02_NA
SYSTEM NAME	ABC123 CABLE
SYSTEM CONTACT	JOHN DOE
SYSTEM LOCATION	123 BAKERVIEW
COMMON LOGICAL ID	12345-3767 ALPHAWAY
DOCSIS CONFIG FILE	ALPHA_DSM3.CM
DSM SERIAL NUMBER	A00499
SYSTEM DEVICES 3-7*	IPU-1 SAG-1 DOC-1
SYSTEM DEVICES 6-7*	XM3-1 APP-1 BTQ-1
SYSTEM DEVICES 7-7*	UTL-1
CABLEWARE SERVER IP	192.168.200.151

* Menu item will populate for only Cableware configured units

COMM - DIAGNOSTICS	
CABLE MODEM STATUS	OPERATIONAL
SYSTEM UPTIME	3 DAYS 05H:16M:59S
DOWNSTREAM FREQUENCY	300.000 MHZ
DOWN MODULATION TYPE	256 QAM
UPSTREAM FREQUENCY	15.000 MHZ
T3 TIMEOUTS	80360
T4 TIMEOUTS	51
CODEWORD ERROR RATIO	8.20%
MICROREFLECTIONS	-5 DBC
CM RESETS	10
CM LOST SYNCS	5
LAST SNMP QUERY	Date/Time

NOTE: System Device menu items are internal Alpha diagnostic codes. The System Devices menu items will populate based on the option cards (SAG, APP, DOC) installed and the number of external devices added to a power system such as multiple XM3s and/or AlphaGen.

Fig. 2-36, COMM Menu Options

2.0 Installation, Continued

2.2.10 Web Interface

Overview

The DSM3/IDH4 Series power supply transponder provides an embedded Web server interface to allow operations personnel the ability to connect locally or remotely via TCP/IP over Ethernet with a laptop/computer to verify the status of common data points and to configure various operating parameters.

Local Web Server Access

The DSM3/IDH4 Series transponder's Ethernet port (comparable to the **Craft** port on some transponder models) will typically be used as a local connection point allowing the user to connect directly to the DSM3/IDH4 Series Web server interface to verify/configure common communication parameters and view power supply status and battery values. The Ethernet port on the DSM3/IDH4 Series is a fully functional standard Ethernet port, capable of providing all the functionality of any standard Ethernet connection.

To access the DSM3/IDH4 Series transponder Web server locally utilizing a Web browser, use the following procedure:

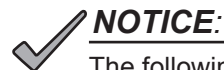

NOTICE:

The following Web Browser settings should be 'enabled' for proper rendering/download of the web pages:

- Java Script
- Cookies
- Activex Controls
- Downloads
- Active Scripting
- Show Pictures

These settings are typically enabled in the Web Browser by default.

1. Connect a standard Ethernet cable (CAT5) between the DSM3/IDH4 Series transponder Ethernet port (ETH) and a laptop or computer's network interface port.
2. Launch a Web browser.
3. Enter the transponder's default IP address (192.168.100.1) into the Web browser's address field.
4. The transponder's Web server home page will appear (Fig. 2-37). **Note: For the DSM3/IDH4 Series, this may take up to 45 seconds when the transponder is initially powered up with no RF connection.**
5. Click the **Language** menu to select a desired language for the text information on the Web page. The language choices are English (default), Spanish, Portuguese, French & German.

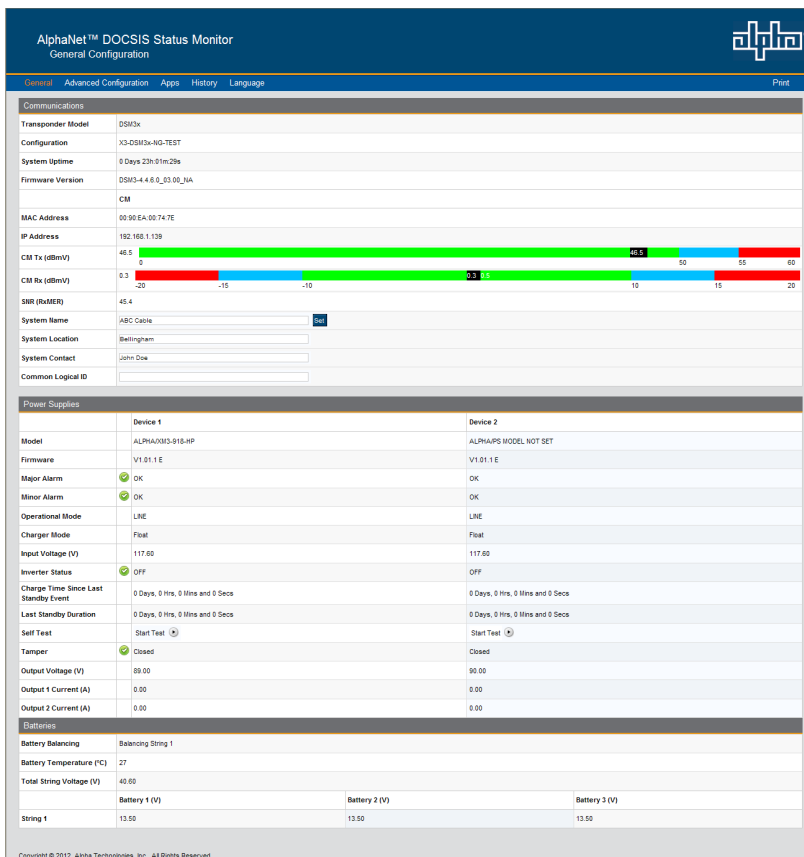

Fig. 2-37, DM3/DSM3/IDH4 Series Web Page
(data values shown for illustration purposes only)

2.0 Installation, Continued

✓ **NOTICE:**

If you are unable to view the home page of the DSM3/IDH4 Series using IP address 192.168.100.1, the network configuration on the computer that is being used to connect to the DSM3/IDH4 Series transponder may require a temporary static IP address to be configured.

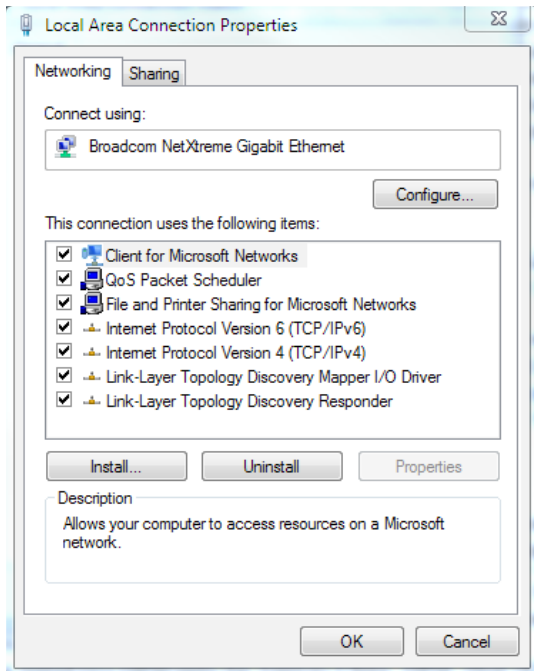

Fig. 2-38, Local Area Connection Properties Screen, Windows 7

Use the following procedure to configure a static IP address on a laptop or computer with the Windows 7 operating system:

1. Click the **Start** button (lower left button on most Windows® computers).
2. When the window pops up, click **Control Panel** (usually about half the way down the second column).
3. Click **Network and Sharing Center**.
4. Click **Local Area Connection**.
5. Click the **Properties** button.
6. You will see a dialog box much like Fig. 2-38; click **Internet Protocol (TCP/IPv4)** and then click the **Properties** button.

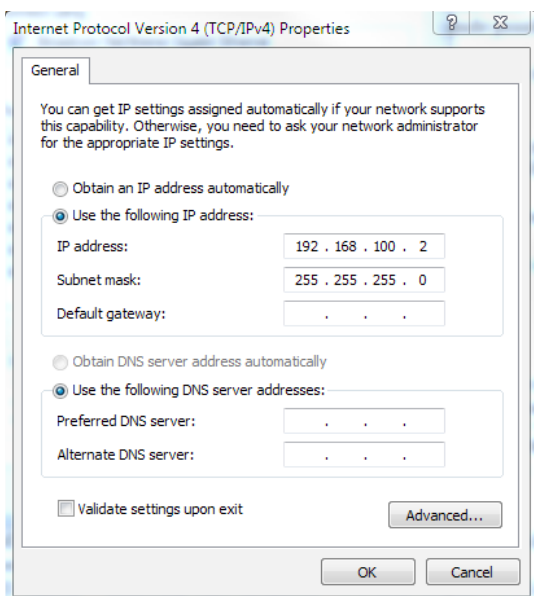

Fig. 2-39, Internet Protocol (TCP/IP) Properties Screen, Windows 7

7. The Internet Protocol (TCP/IP) Properties dialog box will open (Fig. 2-39). Select "Use the following IP address". Enter the values as shown (i.e. IP address 192.168.100.2 and Subnet mask 255.255.255.0). Record the existing IP address and Subnet mask in order to later return the computer to its original state.
8. Click the **OK** button and try to connect to the DSM3 Series transponder once again using 192.168.100.1 in the Web browser.
9. To restore network settings, repeat Steps 1 through 6.

2.0 Installation, Continued

Use the following procedure to configure a static IP address on a laptop or computer with the Windows® 8 or Windows® 10 operating system:

1. Right click the **Start** button (lower left button on most Windows® computers).
2. When the window pops up, click **Control Panel** (usually about half the way down the second column).
3. Click **Network and Sharing Center**.
4. Click **Ethernet**.
5. Click the **Properties** button.
6. You will see a dialog box much like Fig. 2-40; click **Internet Protocol (TCP/IPv4)** and then click the **Properties** button.

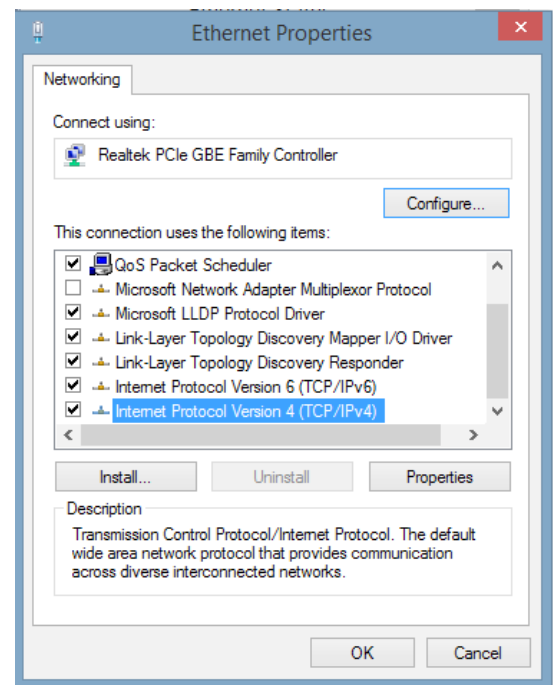

Fig. 2-40, Local Area Connection Properties Screen, Windows 10

7. The Internet Protocol (TCP/IP) Properties dialog box will open (Fig. 2-41). Select “Use the following IP address”. Enter the values as shown (i.e. IP address 192.168.100.2 and Subnet mask 255.255.255.0). Record the existing IP address and Subnet mask in order to later return the computer to its original state.
8. Click the **OK** button and try to connect to the EDH4 transponder once again using 192.168.100.1 in the Web browser.
9. To restore network settings, repeat Steps 1 through 6.

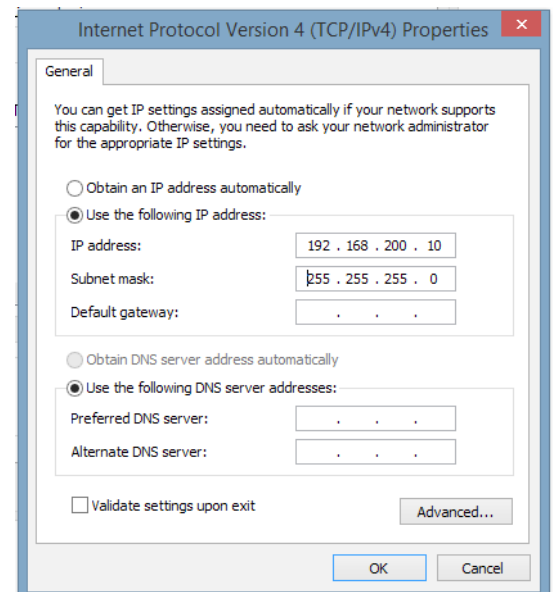

Fig. 2-41, Internet Protocol (TCP/IP) Properties Screen, Windows 10

2.0 Installation, Continued

2.2.11 Remote Web Server Access

To remotely access the DSM3/IDH4 Series transponder Web server utilizing a Web browser, use the following procedure:

NOTICE:

For Web server (HTTP) access, port 80 must not be blocked.

1. Connect the laptop or computer's network interface port to the company's Ethernet network.
2. Open a Web browser.
3. Enter the DSM3/IDH4 Series' DHCP designated IP address (e.g., 192.168.1.124) into the Web browser's address field. Use square brackets when entering IPV6 IP addresses (e.g. [FC00:168:40::124]) into the Web browser's address field.
4. The DSM3 Series transponder's Web server home page will appear (Fig. 2-42).
5. The Web page language will default to the language set on the XM3-HP. To change the language, click on the **Language** menu to select a desired language for the text information on the Web page. English, Spanish, Portuguese, French and German are the options.

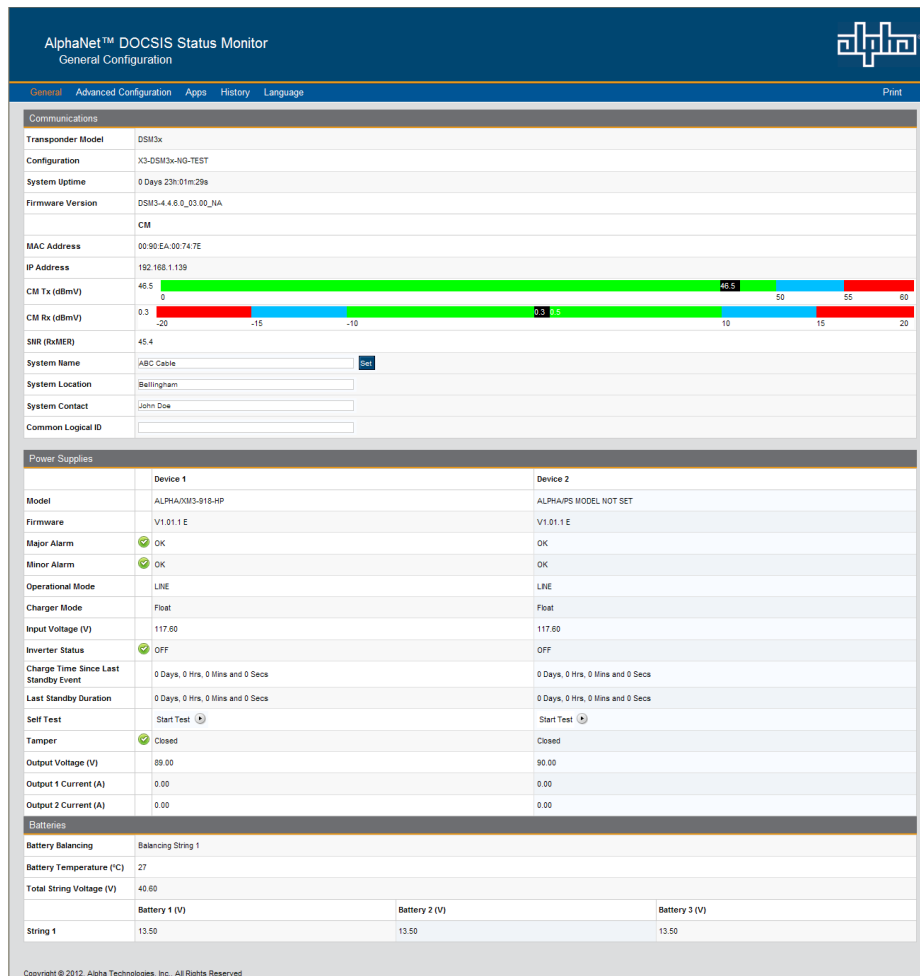

Fig. 2-42, Web Server Home Page
(data values shown for illustration purposes only)

2.0 Installation, Continued

2.2.12 Navigating the Web Page

Once the Web page has been successfully accessed, the operator is able to select a link on the header bar and the page specific to the topic will open enabling real-time data to be observed. See Fig. 2-43 for DSM3/IDH4 Series navigation bar items.

The screenshot shows the AlphaNet™ DOCSIS Status Monitor interface. The header bar includes the title "AlphaNet™ DOCSIS Status Monitor" and "General Configuration" on the left, and the AlphaNet logo on the right. Below the header is a navigation bar with links for "General", "Advanced Configuration", "Tools", "Apps", "History", "Language", and "Print".

Callouts provide the following information:

- Commonly used parameters for quick diagnostics of power supply, Communications, Batteries and Generator.**
- Communications:** Comprehensive communications diagnostic parameters.
- Power Supply:** Comprehensive power supply configuration and configurable parameters.
- Generator:** Comprehensive Generator configuration and diagnostic parameters.
- IO - Environment:** Status and configuration of Tamper polarity and external I/O devices.
- HMS Alarms:** Status of SCTE-HMS active alarms, alarm history and alarm threshold settings.
- Constellation:** Provides a constellation view of the DOCSIS channel for troubleshooting impairments.
- Microreflections:** Provides details about impairments on the network and the approximate distance(s) of those impairment(s). Requires the Adaptive equalization feature to be enabled on the CMTS.
- The Web page content will be displayed in the selected language.**
- System Logs (requires AlphaApp card):** Log overview page provides snapshot of first 5 entries from each of the system logs.
- Power Supply Events (requires AlphaApp card):** Records daily power supply system events.
- Power Supply Configuration (requires AlphaApp card):** Records power supply system configuration events, many of which are set during the initial installation.
- Battery Events (requires AlphaApp card):** Records battery conductance measurements and manufacturing dates.
- Cable Modem Log:** Web page representation of the DOCSIS modem event log.
- (Requires AlphaApp card)**
- Overview:** Provides AlphaApp card version and status, plus Utility power health information.
- Battery Management:** Configure technician ID, battery conductance measurements, battery model and battery manufacturing dates for runtime and battery life calculations.
- Sends the contents of the selected Web page to the computer's default printer.**

Fig. 2-43, DSM3/IDH4 Series Navigation Bar Items

2.0 Installation, Continued

2.2.13 Web Interface Security Levels

Within the DSM3/IDH4 Series transponder are two levels of function-specific security. General operations are set at Level 1 and configuration-related functions are set at Level 2. Default User Name and Security Passwords are shown in Table 2-3.

DSM3 Series Web Page Security		
OID	Function	Value
1.3.6.1.4.1.4413.2.2.2.1.1.3.3.0	Level 1 User Name	Alpha
1.3.6.1.4.1.4413.2.2.2.1.1.3.4.0	Level 1 Security Password	AlphaGet
1.3.6.1.4.1.4413.2.2.2.1.1.3.1.0	Level 2 User Name	Alpha
1.3.6.1.4.1.4413.2.2.2.1.1.3.2.0	Level 2 Security Password	AlphaSet

Web Page	Function	Security Level
General	System Name, System Contact, System Location, Common Logical ID	1
	Power Supply Self Test	1
	Generator Self Test	1
Advanced Communications	Reset Transponder	1
	Provisioning Mode - Single IP or Dual IP	2
	Configure Static IP Address	2
	Configure Proprietary Trap Addresses	2
Advanced Power Supply	Power Supply Self Test	1
	Configure/Save	2
	Reset Output 1/2	2
Advanced Generator	Generator Self Test	1
	Reset Latched Alarms	1
Modem Log [Event Log]	Reset Log	1
Advanced I/O	Tamper Switch Polarity	1
	Enclosure Heater/Cooler Installed	1
HMS Alarms	Export Alarm Cloning File	2
Apps Overview	Configure/Save	2
Battery Management	Configure/Save	2

Table 2-3, DSM3/IDH4 Series Transponder Security Levels

2.0 Installation, Continued

2.2.14 Verifying Communication Parameters

Click the **General** menu of the web page to display common communication settings and values. The System Name, System Location, System Contact and Common Logical ID may be entered via the General Web page, see Figure 2-44. Click the Set button to update the change once the values have been entered. Refer to **Section 2.2.13 Web Interface Security Levels** for User Name and Security Password. Click the **Advanced Communication** menu to view additional communication parameters, see Figure 2-45.

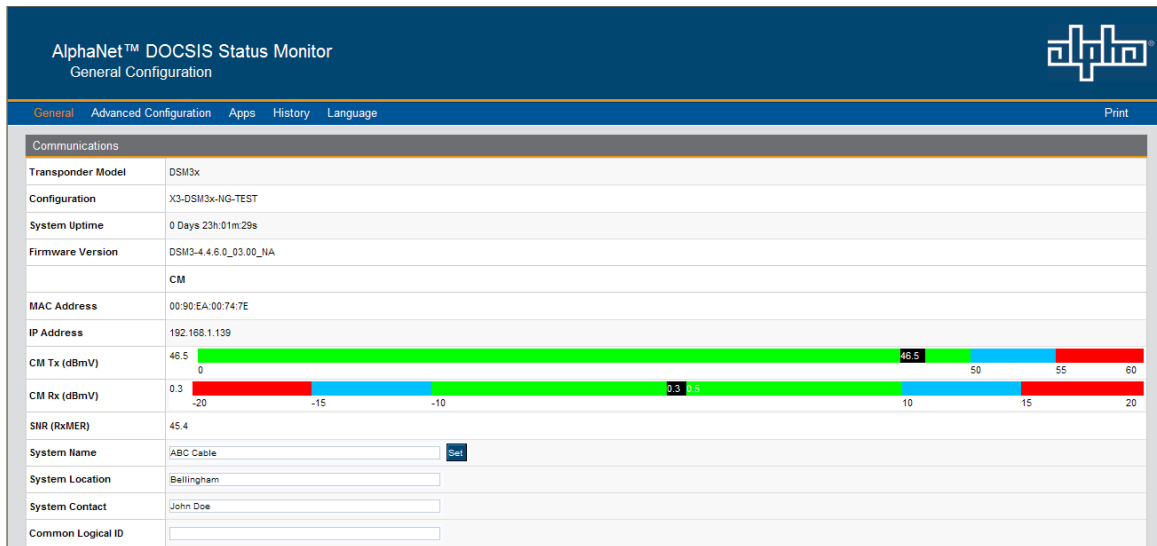

Fig. 2-44, Communication Parameters
(data values shown for illustration purposes only)

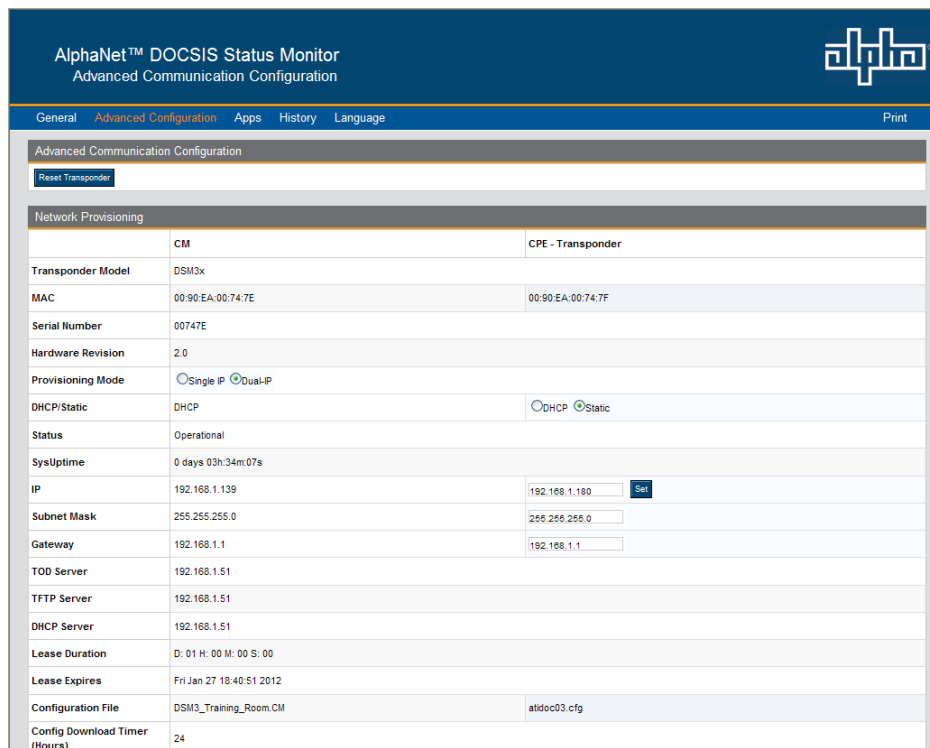

Fig. 2-45, Advanced Communication Parameters
(data values shown for illustration purposes only)

2.0 Installation, Continued

2.2.15 Verifying Power Supply and Battery Parameters

Click the **General** menu to access power supply and individual battery voltage values. Important parameters such as current alarm status, inverter status and tamper status can be quickly verified on this page. Additional power supply parameters can be viewed and configured on the power supply page located in the **Advanced Configuration** menu, see Figure 2-39.

Power Supplies	
Device 1	
Model	ALPHA0013-915-HP
Firmware	V1.04.0 H
Major Alarm	OK
Minor Alarm	OK
Operational Mode	LINE
Charger Mode	Float
Input Voltage (V)	118.00
Inverter Status	OFF
Charge Time Since Last Standby Event	0 Days, 0 Hrs, 0 Mins and 0 Secs
Last Standby Duration	0 Days, 0 Hrs, 0 Mins and 0 Secs
Self Test	Start Test
Tamper	Closed
Output Voltage (V)	90.00
Output 1 Current (A)	0.00
Output 2 Current (A)	0.00

Batteries			
Battery String Runtime Remaining	Calculating		
Battery Balancing	Idle		
Battery Temperature (°C)	31		
Total String Voltage (V)	40.00		
	Battery 1 (V)	Battery 2 (V)	Battery 3 (V)
String A	13.20	13.20	13.20

Copyright © 2012, Alpha Technologies, Inc., All Rights Reserved

Fig. 2-46, Power Supply and Battery Parameters
(data values shown for illustration purposes only)

2.2.16 Remote Self Tests via the Web Page

Remote Self Tests on power supplies may be started and stopped via the DSM3/IDH4 Series Web page. This requires a Level 1 login. Refer to **Section 2.2.12.1, Web Interface Security Levels** for User Name and Security Password.

To launch a remote Self Test, click on the **Start Test** button, see Figure 2-47.

To stop a remote Self Test before the predefined test duration, click on the **Stop Test** button.

Power Supplies	
Device 1	
Model	ALPHA0013-915-HP
Firmware	V1.04.0 H
Major Alarm	OK
Minor Alarm	OK
Operational Mode	LINE
Charger Mode	Float
Input Voltage (V)	118.00
Inverter Status	OFF
Charge Time Since Last Standby Event	0 Days, 0 Hrs, 0 Mins and 0 Secs
Last Standby Duration	0 Days, 0 Hrs, 0 Mins and 0 Secs
Self Test	Start Test
Tamper	Closed
Output Voltage (V)	90.00
Output 1 Current (A)	0.00
Output 2 Current (A)	0.00

Batteries			
Battery String Runtime Remaining	Calculating		
Battery Balancing	Idle		
Battery Temperature (°C)	31		
Total String Voltage (V)	40.00		
	Battery 1 (V)	Battery 2 (V)	Battery 3 (V)
String A	13.20	13.20	13.20

Fig. 2-47, Location of "Start" Button for Self Test
(data values shown for illustration purposes only)

3.0 Operation

3.1 Start-Up and Test

3.1.1 Self Test Operation

1. The power supply should be operating correctly with no alarms present. Use the Smart Display to verify Normal and Communication Information. Verify Test Duration setting in the Power Config menu screen.
2. Press the Self Test button on the Inverter Module to start Self Test. The test will run for a preset time (5-180 minutes, set in the Power Config Menu). Self Test can also be entered by setting Self Test to ON in the Power Config Menu. Additionally, the Self Test can be configured to perform a deep-discharge of 10%, 20%, 30%, 40% and 50% of battery capacity. When the deep discharge is complete, it will revert back to the Timed Test.
3. While in Self Test mode, use the Smart Display or a true RMS voltmeter to verify output. Output voltages should appear within the ranges listed in Table 3-1. To cancel a Self Test in progress, press the Self Test button a second time or change Self Test to OFF in the Power Config Menu.

 **NOTICE:**

Possible measurement points for output voltage are an unused output connector or the SPI coax seizure screw.

Voltage Regulation (% Range)		
Voltage Setting	Fine (-2.5%/+1%)	Coarse (-5%/+1%)
89VAC	86.77VAC / 89.89VAC	84.6VAC / 89.89VAC
63VAC	61.43VAC / 63.63VAC	59.85VAC / 63.63VAC
48VAC	46.8VAC / 48.48VAC	45.6VAC / 48.48VAC

Table 3-1, AC Output

 **NOTICE:**

A Self-Test Fail alarm will be activated and appear on the Smart Display and Transponder web page if the XM3 detects one or more defective battery strings or problem with the Inverter Module. Replace batteries or module as required. For firmware 1.13.0 and higher, this is a latched alarm and power cycling the Inverter Module will not clear the alarm. This alarm can only be cleared by successfully running in self-test for a minimum of one minute.

3.0 Operation, Continued

3.2 Using the Smart Display

All operational functions, system testing, menus and alarms are available via the illuminated Smart Display. Display functions are accessible by following the indicated prompts above the four softkeys. Descriptions of the menu functions are as follows:

Menu	Function (from Operation Normal Screen)
PWR (Power)	Pressing the softkey below PWR once opens the Power Information and Configuration Menu. From this menu, the operator can view the current power supply configuration or access the PWR CONFIG menu to adjust parameters.
BATT (Battery)	Pressing the softkey below BATT once opens the Battery Information and Configuration Menu. From this menu, the operator can view the current battery information or type and adjust battery parameters as necessary.
COMM (Communications)	Pressing the softkey below COMM once opens the Communication Information and Configuration Menu. From this menu, the operator can access additional menus (General/Extended/Diagnostics) to view and/or modify COMM parameters.
APPS (Applications)	Pressing the softkey below APPS once opens the Application Information and Configuration Menu. From this menu, the operator can view or modify parameters for the installed APP card.

Table 3-2, Main Menu Functions

Display Text & Backlighting: During inactivity, both the text and backlighting will be turned off. Press any softkey once to activate the text and backlighting on the display. When the Alarm LED has been activated, press any softkey to activate the display for alarm details.

Moving up and down the menu: Press the up or down arrow softkey to access menu items in the active screen (see Fig. 3-2). Each press of the softkeys steps up or down through the sub-menu items. Press the softkey beneath ENTR to access the next menu option. Press the softkey beneath ESC to return to the previous screen.

Model Name: For firmware version 1.14.0 and higher, the Model name has been replaced with the Input Voltage/Current on the home screen. To access the Model, press the two left buttons.

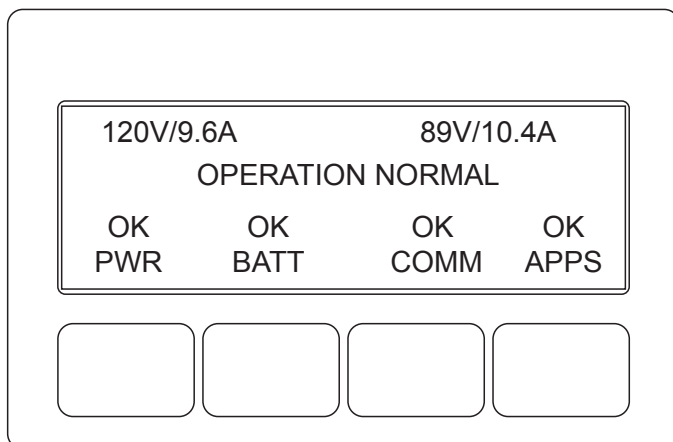

Fig. 3-1, Operation Normal Display Screen

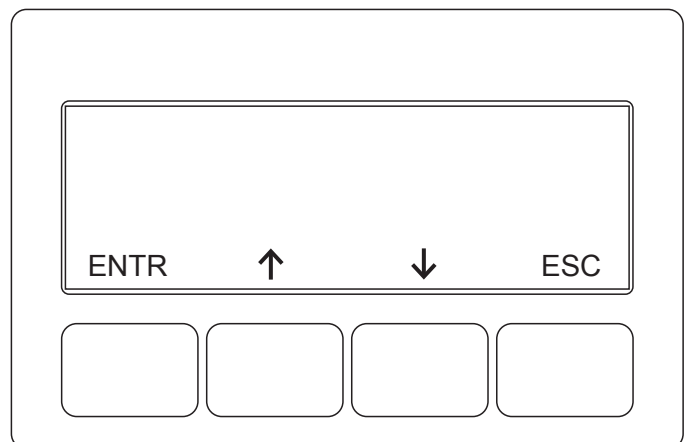

Fig. 3-2, Navigating Through Menu Screens

3.0 Operation, Continued

3.3 Smart Display Menus

While in the OPERATION NORMAL display, the following menu prompts are displayed when the respective softkey is pressed.

NOTICE:

For the XM3-918D-HP, the Input Voltage Settings screen will appear. Correct voltage must be set in order to exit this screen (see Fig. 3-3).

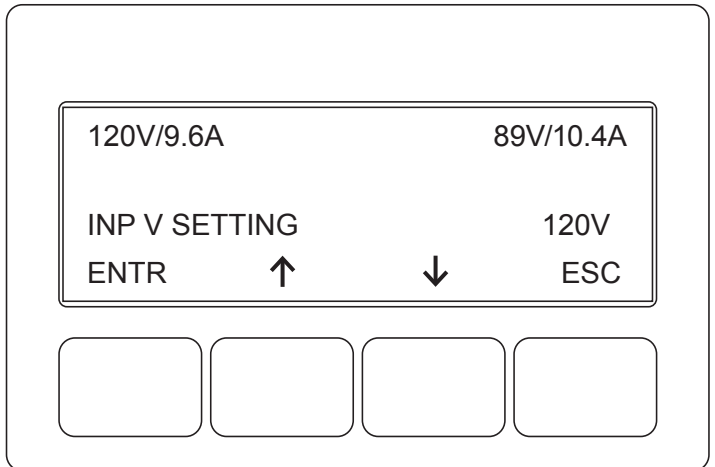
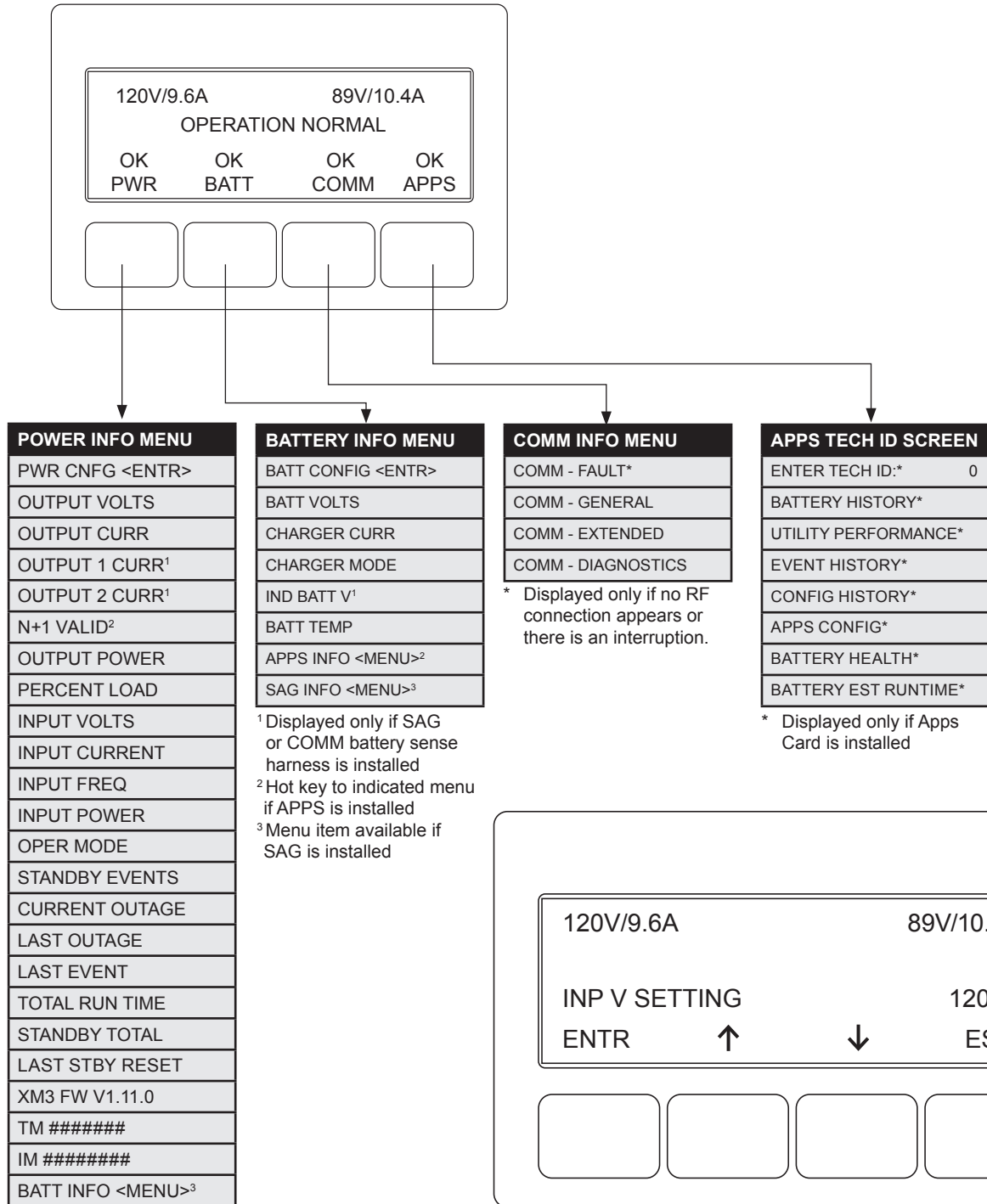
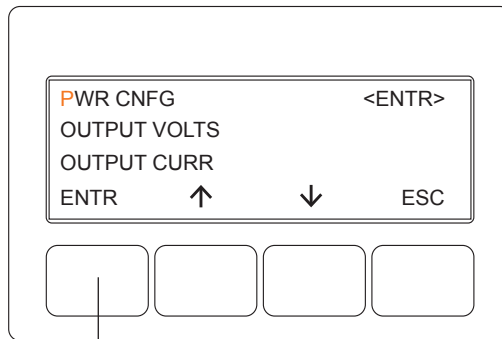

Fig. 3-3, Input Voltage Settings Screen

3.0 Operation, Continued

3.3.1 Power Information and Configuration

Pressing the PWR (Power) softkey while in the OPERATION NORMAL screen opens the Power Info Menu display (the first letter of the top line will blink indicating it is the active line; shown in orange). Pressing ENTR from this screen opens the PWR CNFG Menu. Cycling through each menu item and following the prompts on the lower line will enable the user to configure the parameters shown in the menu.



POWER INFO MENU		
PWR CNFG <ENTR>		
OUTPUT VOLTS	48,63 or 89 VAC	0–101 VAC
OUTPUT CURR	10.5A	0–40 A
OUTPUT 1 CURR ¹	6.8A	
OUTPUT 2 CURR ¹	8.0A	
N+1 VALID ²		YES/NO
OUTPUT POWER	2000W	
PERCENT LOAD	80%	0–255%
INPUT VOLTS	120V	0–325 VAC
INPUT CURRENT	(4.5A)	0–25 A
INPUT FREQ	60HZ	42HZ–67.5HZ
INPUT POWER	2000W	
OPER MODE		LINE/STANDBY
STANDBY EVENTS		0–65535 EVENTS
CURRENT OUTAGE		0–65535 MIN
LAST OUTAGE		0–65535 MIN
LAST EVENT	(DD:HH:MM)	
TOTAL RUN TIME		0–65535 DAYS
STANDBY TOTAL		0–65535 MIN
LAST STBY RESET		0–65535 DAYS
XM3 FW V1.11.0	Vx,xx,x	
TM #####		
IM #####		
BATT INFO	<ENTR>	

Power Config Menu	Default	Range
SELF TEST	OFF	ON / OFF
TEST INTERVAL	30 DAYS	0–365 DAYS
TEST DURATION	10 MIN	5–180 MINUTES
TEST COUNTDOWN	30 DAYS	0–365 DAYS
TEST INHIBIT		+7 Days=Test Inhibit; 0=OFF
DISCHARGE LVL	TIMED	TIMED, 10–50%
FREQ RANGE	3.0HZ	1–6HZ
ALPHADOC OPTION	AUTO	NO / YES
ALPHADOC FW	VX.XX.X	
DOC #####		
OUTPUT 1 RESET	ON	NO ¹
OUTPUT 2 RESET	ON	NO ¹
CURR LIMIT 1	110% RATING	3.0–25.0A ²
CURR LIMIT 2	110% RATING	3.0–25.0A ²
RETRY DELAY	60S	5–301S ²
RETRY LIMIT	20	0–40 ²
OVER CURR TOL	3000MS	20–9900MS ²
OUTPUT VOLT REG ³		FINE/COARSE
RMODE	DISABLE	ENABLE/DISABLE
PS PRIORITY		NORMAL
INPUT LIMIT		
INP V SETTING ⁴		120V/240V
SET DEFAULTS	NO	NO / YES
RESET STANDBY	NO	NO / YES
DEVICE ADDRESS	1	0–5
SELECT LANGUAGE	English	Spanish, French, Portuguese, German

Hidden if no AlphaDOC is installed

* Displayed only if AlphaDOC with N+1 option is installed

¹ Output 1 & 2 Reset will be hidden if the corresponding output is not tripped.

² Ability to select available if Optional AlphaDOC installed

³ Hidden for XM3-918D-HP models

⁴ Displayed only for XM3-918D-HP models

3.0 Operation, Continued

3.3.2 Battery Information and Configuration

The top line of the display is affected by pressing a softkey. In this case, pressing Enter <ENTR> will open the BATTERY INFO/BATTERYCONFIG Menu enabling the operator to set values for the following parameters.

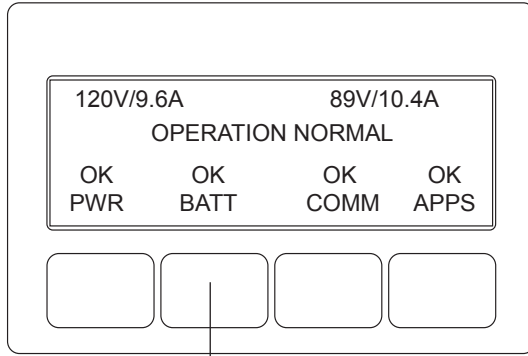

BATTERY INFO MENU	NOTE
BATT CONFIG <ENTR>	Pressing enter goes to the Battery Configuration menu shown below
BATT VOLTS	Displays combined string voltage
CHARGER CURR	Displays Batt Current for Inverter Mode
CHARGER MODE	Displays current Charger Mode: OFF/FLOAT/REFRESH
IND BATT V	Not displayed if no DSM3/IDH4/DM3 or SAG installed
BATT TEMP	Displays battery temperatures (°C)
APPS INFO <ENTR>	Pressing enter goes to the APPS/INFO menu on APPS Tab*
SAG INFO <ENTR>	Pressing enter goes to the SAG INFO menu shown at right

* Displays only if Apps Card is installed

INDIVIDUAL BATTERY VOLTS MENU
BATT A1 VOLTS*
BATT A2 VOLTS*
BATT A3 VOLTS*
BATT B1 VOLTS*
BATT B2 VOLTS*
BATT B3 VOLTS*
BATT C1 VOLTS*
BATT C2 VOLTS*
BATT C3 VOLTS*
BATT D1 VOLTS*
BATT D2 VOLTS*
BATT D3 VOLTS*
NO BATTERIES**

* Displays only if battery is present
 ** Displays if no batteries are present

SAG INFO
BALANCING STR*
DUR REMAIN ##### M**
A MAX DELTA ##### mV**
B MAX DELTA ##### mV**
C MAX DELTA ##### mV**
D MAX DELTA ##### mV**
A BAL STAGE MODERATE**
B BAL STAGE MODERATE**
C BAL STAGE MODERATE**
D BAL STAGE MODERATE**
A SEVERE DUR ##### M**
B SEVERE DUR ##### M**
C SEVERE DUR ##### M**
D SEVERE DUR ##### M**
BALANCER DIS YES/NO
POWERSAVE MODE YES/NO
NUM OF STRINGS ##
SAG HARDWARE ID

* Displays NONE if no strings are being balanced
 ** Displays only if string is present

BATTERY CONFIG MENU	DEFAULT	RANGE	NOTE
BATT MHOS	0	0-2550	Hidden if no APPS card is installed
BATT DATES	User programmable		
BATT MODEL	OTHER		AlphaCell models listed at right
BATT STR DETECT	AUTO	AUTO / MANUAL	
NUM BATT STRINGS	1	1-4	
BATT CAPACITY	100AH	0*, 1-1000	Automatically set when AlphaCell model is selected.
FLOAT	2.27V/C	2.10-2.35	
ACCEPT	2.40V/C	2.20-2.45	
REFRESH	2.45V/C	2.40-2.50	
REST ENABLE	OFF	ON/OFF	
TEMP COMP	5.0MV	0-5.0MV per cell	
EOD TYPE	STRING	IND or STRING	Individual Battery EOD only if sense harness is connected Will display STR OVER for STRING override mode
EOD VOLT	1.75V/C		Hidden if EOD TYPE = STRING
REFRESH ENABLE	ON	ON/OFF	Pressing Enter goes to adjust screen
SAG OPTION			Auto-recognize Smart AlphaGuard (SAG)
SAG FW V1.00.0	AUTO		Hidden if no SAG connected
SAG #####			Hidden if no SAG connected
HEATER MAT	NO	YES/NO	Pressing Enter goes to adjust screen

* BATT CAPACITY should only be set to "0" when no batteries are present to disable NO BATT Alarm.

AlphaCell Batteries
OTHER
NO BATT*
4.0HP
3.5HP
240XTV
195XTV
150XTV
100XTV
220GXL
195GXL
165GXL
195GOLD
220GOLD
180GXL
210GXL
170XLT
18V4XTV

* NO BATT will display instead of OK BATT if this is selected

3.0 Operation, Continued

3.3.3 Configuring XM3-HP for XTV 18V4 Batteries

To configure XTV 18V4 batteries used with an XM3-HP Power Supply, follow the procedure below:

NOTICE:

18V4XTV is a selectable option from the BATT MODEL list for XM3 Power Supplies configured with Platform 14 firmware.

XTV 18V4 Battery Configuration from Operation Normal Screen:

From the OPERATION NORMAL screen, press **BATT** softkey to access the BATTERY INFO MENU.

Press **ENTR** to open the BATT CONFIG MENU.

Press Down arrow to move BATT MODEL to top line of display.

Press **ENTR** to open selection function.

Press **UP** or **DOWN** arrows to move through the list of available batteries. Select 100XTV if listed.

Press **ENTR** ("New Data Accepted" confirmation appears)

Default values for BATT CAPACITY, FLOAT, ACCEPT and Temp Comp will be automatically set.

Press **ESC** twice to return to main screen.

XTV 18V4 Battery Configuration from Active Alarm Screen:

From Active Alarm screen (with ALM BATT indicated)

Press ALM BATT softkey

Press **DOWN** arrow to place BATT INFO at top line of display.

Press **ENTR** to open BATT INFO screen

Press **ENTR** to open BATT CONFIG menu

Press Down arrow to move BATT MODEL to top line of display

Press **ENTR** to open selection function

Press **UP** or **DOWN** arrows to move through the list of available batteries. Select 100XTV if listed.

Press **ENTR** ("New Data Accepted" confirmation appears)

Default values for BATT CAPACITY, FLOAT, ACCEPT and Temp Comp will be automatically set.

Press **ESC** twice to return to main screen.

OTHER Battery from Operation Normal or Alarm Screen:

If the 100XTV battery is not listed, press the **UP** or **DOWN** arrows to OTHER

Press **ENTR** ("New Data Accepted" confirmation appears)

Press **DOWN** arrow to BATT CAPACITY line

Press **ENTR** to enable change

Make changes (enter values from Table 3-3) with **UP** or **DOWN** arrow keys

When correct, press **ENTR** ("New Data Accepted" confirmation appears)

Repeat for FLOAT, ACCEPT, and TEMP COMP

Press **ESC** twice to return to main screen.

ALPHACELL = OTHER BATT CAPACITY = 55Ah Float V/C = 2.35 ACCEPT V/C = 2.25 Temp Comp = 3.3mV

After selecting OTHER, manually enter these values for each item.

Table 3-3, OTHER Battery Values

3.0 Operation, Continued

3.3.4 Communication Information and Configuration

Pressing the COMM softkey while in the OPERATION NORMAL screen opens the following display (the first letter of the top line will blink indicating it is the active line).

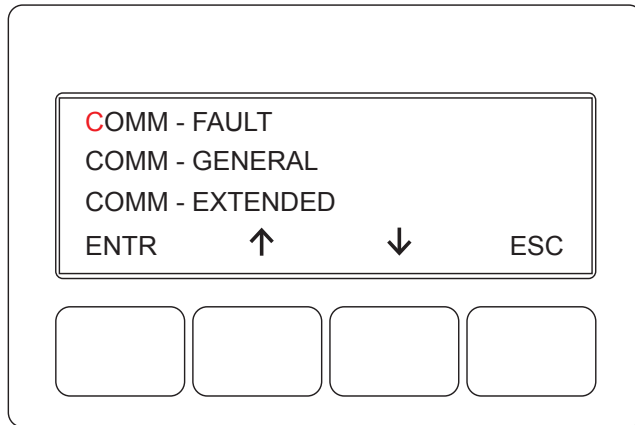

COMM-FAULT

The top line of the display is affected by pressing a softkey. Pressing Enter <ENTR> will open the COMM-FAULT Menu. The COMM-FAULT Menu will appear if there is no RF connection or the RF connection is interrupted.

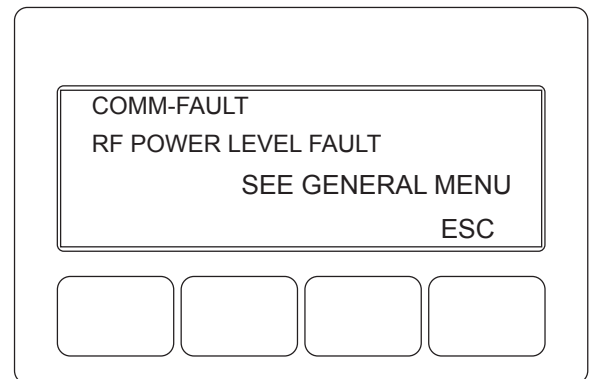

COMM-GENERAL

In this case, pressing Enter <ENTR> will open the COMM-GENERAL Menu enabling the operator to view values for the following parameters. Pressing the up or down arrow softkeys will show two lines of information for each submenu item.

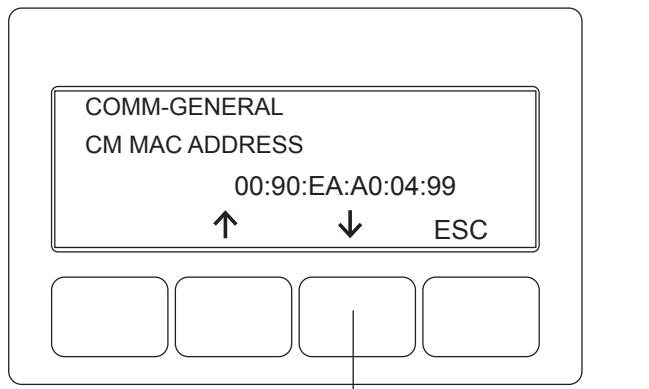

Press "Down" arrow softkey to view next item(s) in menu.

COMM GENERAL	
CM MAC ADDRESS	00:90:EA:A0:04:99
CM IP ADDRESS	192.168.1.121
CM IPV6 ADR PREFIX*	2001:123:456:789
CM IPV6 ADR POSTFIX*	111:222:333:3434
CPE MAC ADDRESS**	00:90:EA:A0:04:9A
CPE IP ADDRESS**	192.168.1.122
CM RECEIVE POWER	-2.1dBmV
CM TRANSMIT POWER	48.5dBmV
DOWNSTREAM SNR	40.5dB

* Menu item available if DSM3 is provisioned in IPv6 mode

** Menu item available if DSM3 is provisioned in Dual-IP mode

3.0 Operation, Continued

Pressing the down arrow softkey to move COMM-EXTENDED (the first letter of the top line will blink indicating it is the active line) to the top line and press ENTR to open the COMM-EXTENDED menu.

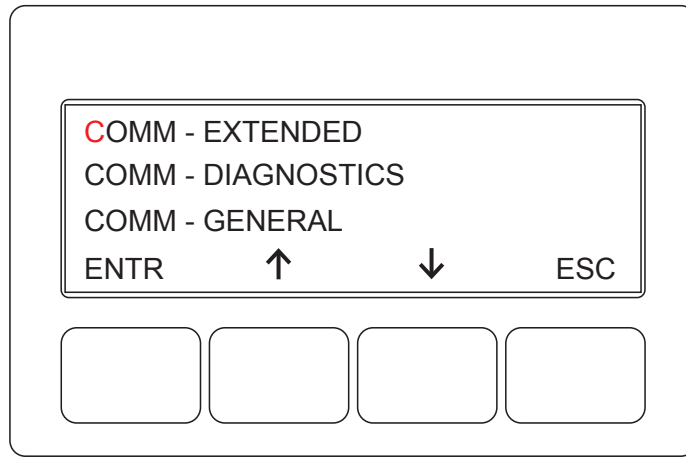

COMM-EXTENDED

Pressing Enter <ENTR> opens the COMM-EXTENDED menu enabling the operator to view values for the following parameters. Pressing the up or down arrow softkeys will show two lines of information for each submenu item.

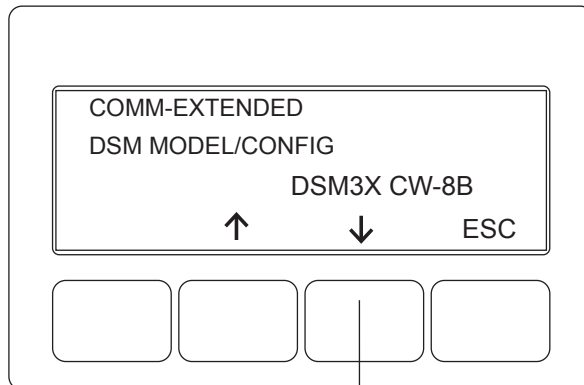

Press "Down" arrow softkey to view next item(s) in menu.

COMM - EXTENDED
DSM MODEL/CONFIG
DSM3X CW-8B
DSM FIRMWARE VERSION
4.4.9.0_03.02_NA
SYSTEM NAME*
ABC123 CABLE
SYSTEM CONTACT*
JOHN DOE
SYSTEM LOCATION*
123 BAKERVIEW
COMMON LOGICAL ID
DSM3
DOCSIS CONFIG FILE
ALPHA_DSM3.CM
DSM SERIAL NUMBER
a00499
SYSTEM DEVICES 3/7
IPU-1 SAG-1 DOC-1
SYSTEM DEVICES 6/7
XM3-1 APP-1 BTQ-1
SYSTEM DEVICES 7/7
UTL-1
CABLEWARE SERVER IP**
192.168.200.151

* User Input values are examples only.

** Menu item will only populate for Cableware configured units

3.0 Operation, Continued

Pressing the down arrow softkey to move COMM-DIAGNOSTICS (the first letter of the top line will blink indicating it is the active line) to the top line and press ENTR to open the COMM-DIAGNOSTICS menu.

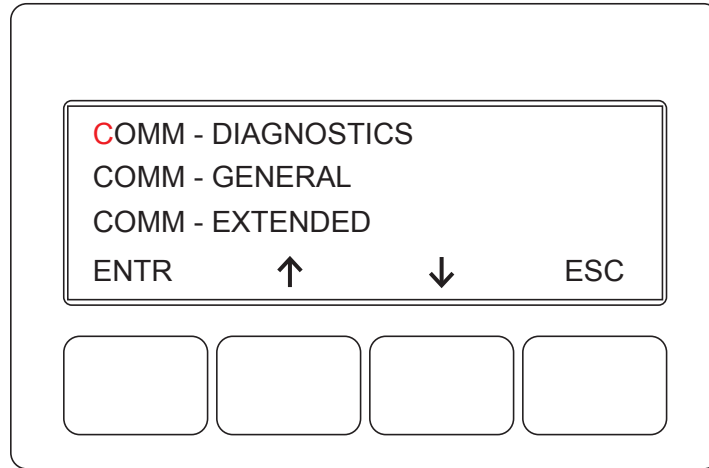

COMM-DIAGNOSTICS

Pressing Enter <ENTR> opens the COMM-DIAGNOSTICS menu enabling the operator to view values for the following parameters. Pressing the up or down arrow softkeys will show two lines of information for each submenu item.

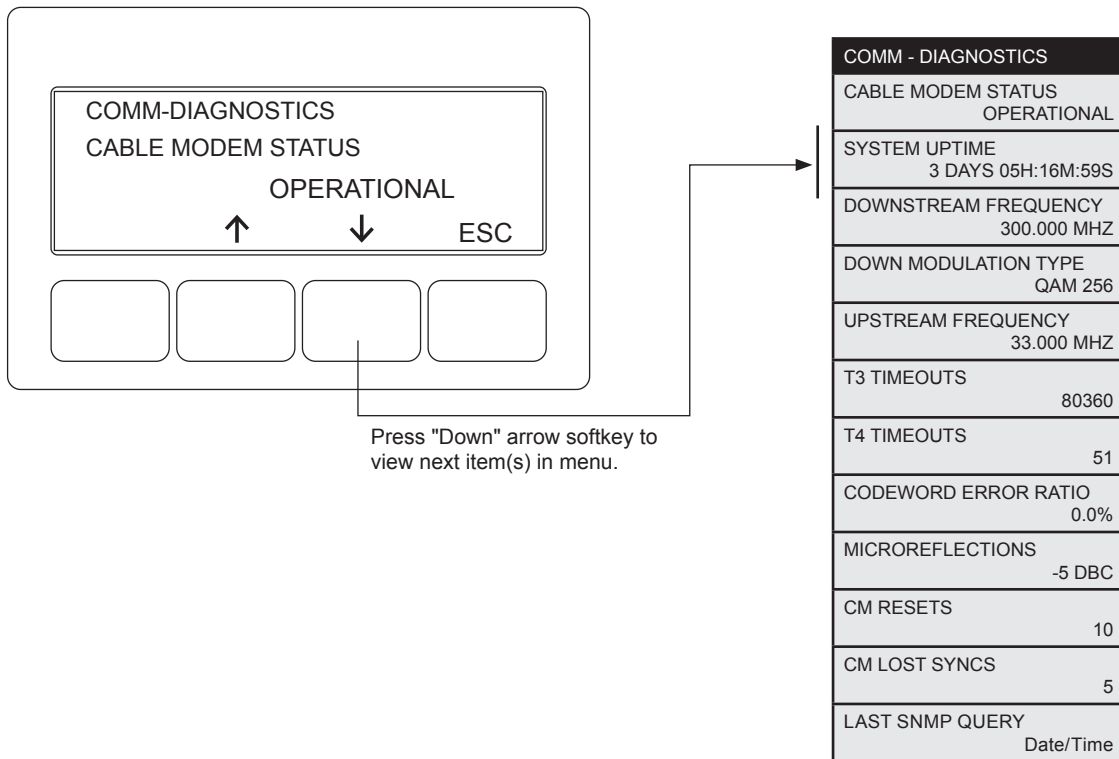

3.0 Operation, Continued

3.3.5 Alpha Applications Information and Configuration

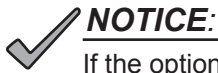

NOTICE:

If the optional APPS card is not installed, NO APPS will appear on the Smart Display, and the values shown under the “APPS OPTION” line of the Smart Display are hidden.

Pressing the OK APPS softkey while in OPERATION NORMAL screen opens the APPS TECH ID screen. The technician may bypass this screen by pressing ENTR with a number 0 on the display, or the technician may enter a number using the up and down arrow keys and then pressing ENTR. If a technician ID is entered, a confirmation screen will appear. Press ENTR again to commit the value and the APPS menu list will appear.

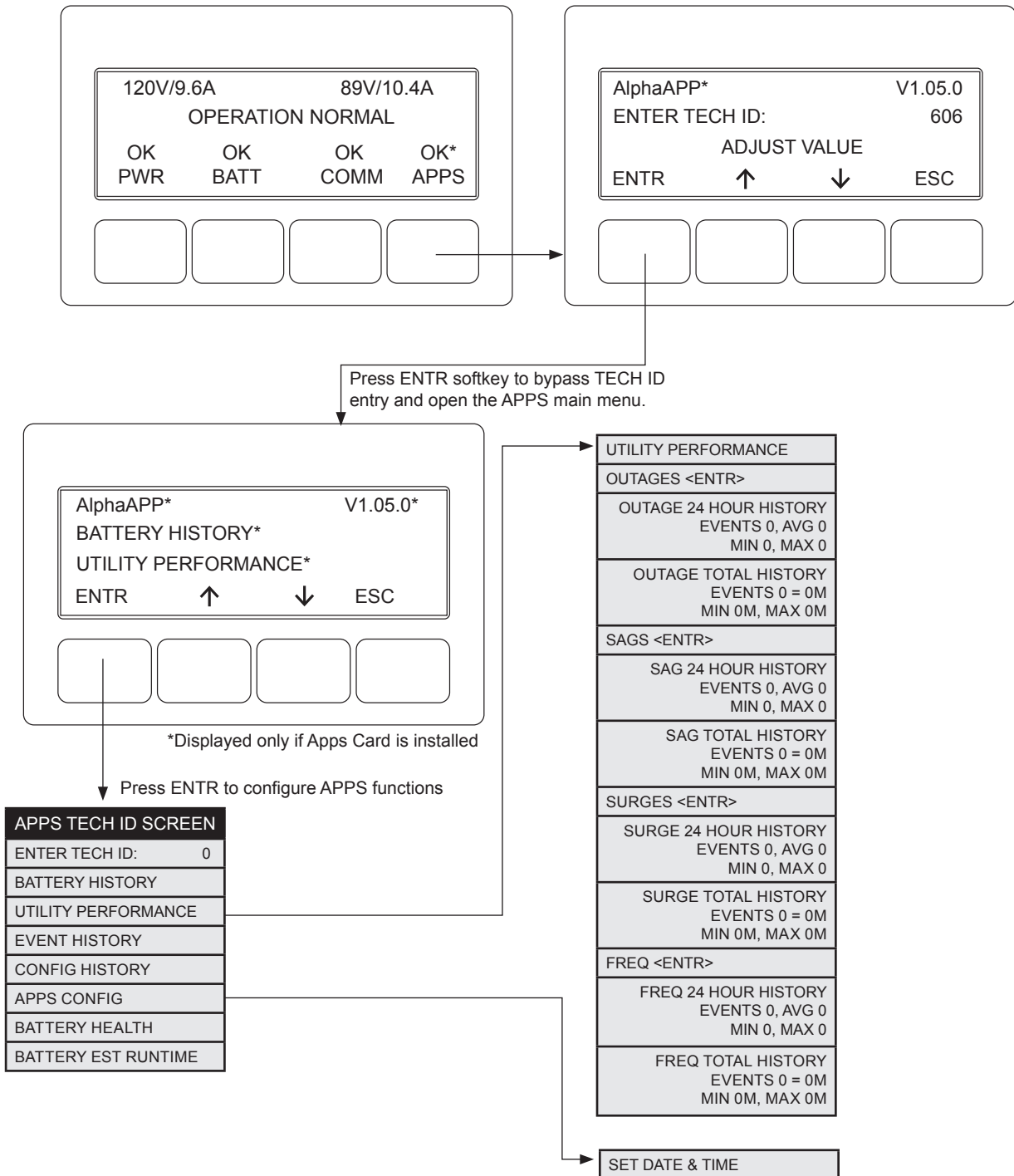

3.0 Operation, Continued

3.4 AlphaAPPs Overview

The AlphaAPPs (applications) card is an optional coprocessor card for the XM3 power supply. It operates as an independent computing system gathering telemetry from the power supply, batteries and the environment. The embedded Alpha APP Operating System and Flash File System provides the customer with an expandable platform for future software applications. As new applications are developed, they can be downloaded over the power supply cable modem interface. The AlphaAPPS details may be viewed on the power supply display, the Alpha Transponder Web APPs pages, and some are supported on the Continuity and Alpha XD status monitoring systems.

3.4.1 Display Structure

Technician ID Screen:

To access the APPS screens press the APPS softkey on the main XM3 menu. The first APP screen displayed will be the Technician ID screen (orange denotes a flashing character in this document).

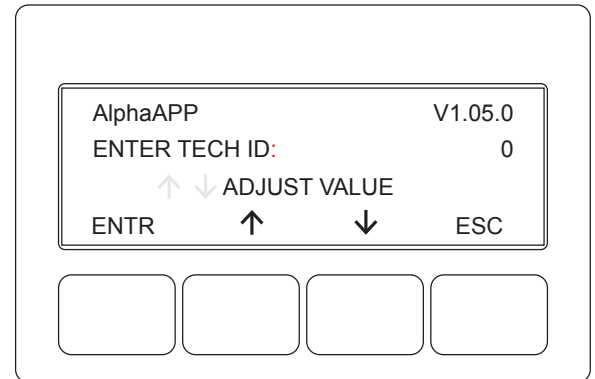

If the technician wishes to have their visit logged, they may enter their ID number (up to 999) by pressing the up and down arrow softkeys and then press the ENTR softkey. The technician ID may be bypassed by pressing the ENTR softkey with an ID of zero.

If a non-zero ID is entered, a confirmation screen will appear. It shows the ID and the time stamp.

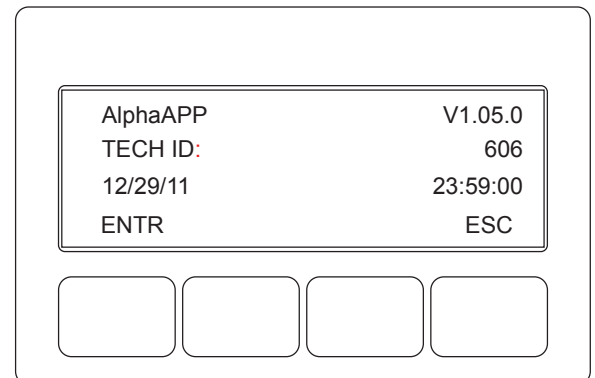

Press ENTR once again to confirm the entry. The APP main menu screen will appear.

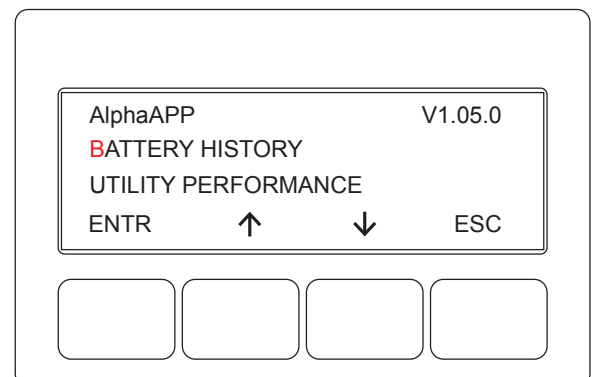

3.0 Operation, Continued

Main APP Menu Screen:

The main menu screen can scroll up or down using the arrow softkeys. The flashing character (shown in orange) denotes which sub-menu will be selected when ENTR is pressed.

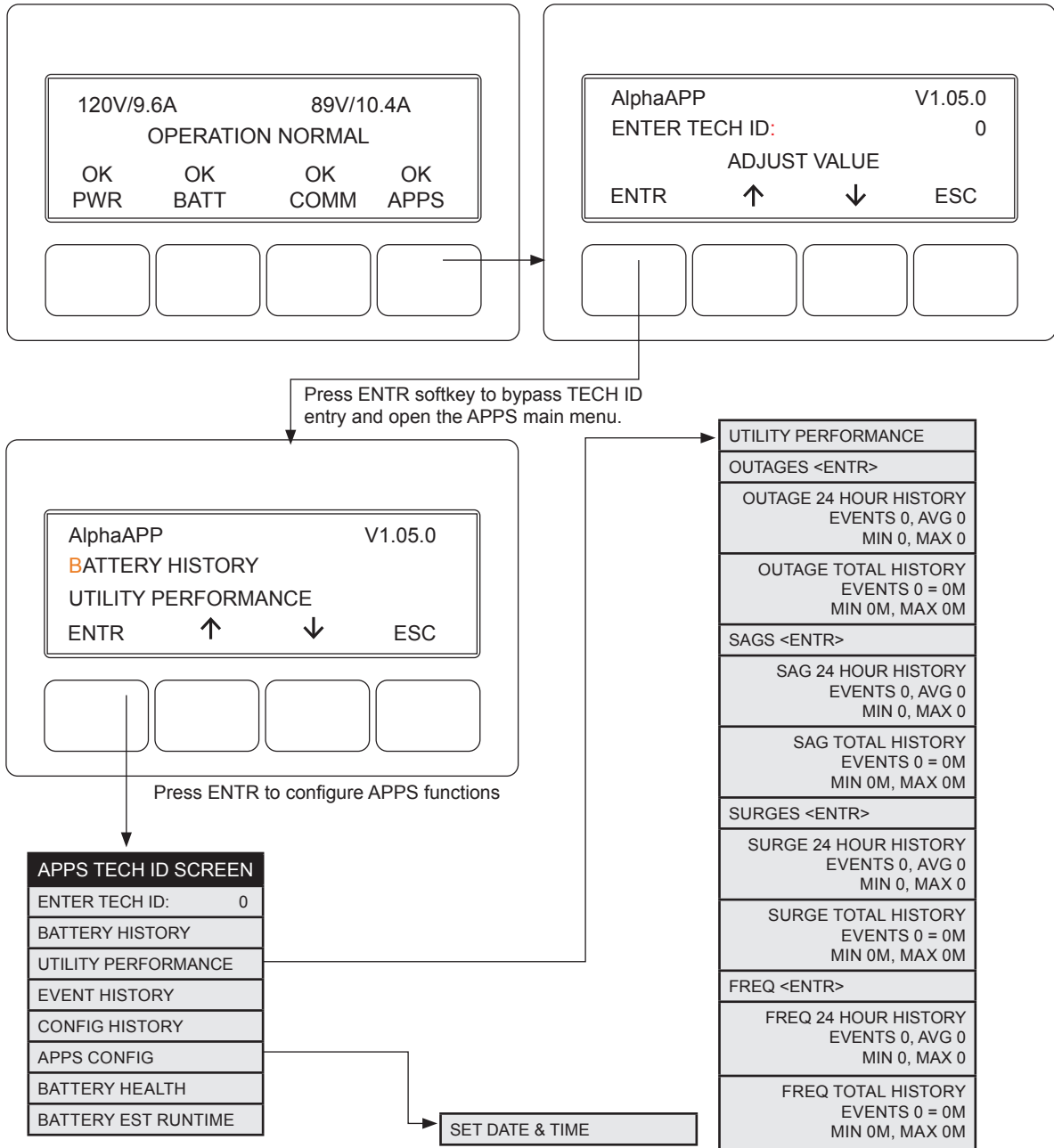

The date and time can be set in the APPS CONFIG menu. The date and time are normally set by a time server at the headend. In the event no time server is present, the APPS card will find the last event log time stamp and use that date and time as clock initial value.

If the date and time needs to be manually entered, use the arrow softkeys to select the digit and use the ENTR to shift fields.

When the "OK" is flashing, press ENTR one more time to save the value. Press ESC if no changes to the date or time are desired.

3.0 Operation, Continued

3.4.2 Applications

There are currently six applications:

1. Configuration Logging
2. Alarm Event Logging
3. Battery Information Logging
4. Utility Performance
5. Battery Health
6. Battery Run Time

Configuration Log Screen:

To enter the Configuration History screen, scroll up or down until the CONFIG HISTORY is at the top of the scroll area.

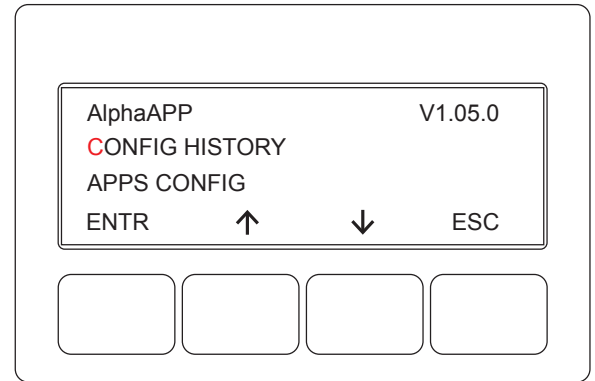

Press ENTR to access the CONFIG HISTORY screen. The "CL" indicates that this is a Configuration Log record, and the time stamp shows when the record was created. Lines two and three on the display contain the record contents. In this example, the APP firmware version record is shown.

The screen will begin with the most recent record created. Press the down(↓) softkey to view earlier records, or press the up(↑) softkey to view more recent records.

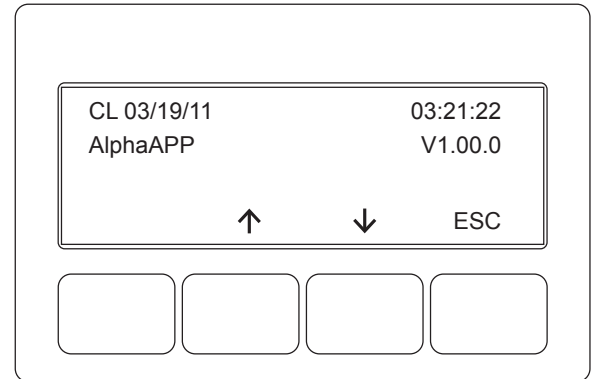

3.0 Operation, Continued

Event Logging App:

The APP card can log 768 events. This log does roll-over when the maximum size has been reached. When the roll-over occurs, the oldest 64 records are erased to make room for new records. Once a roll-over has occurred, the number of records available will be between 704 and 768. See Table 3-3 for a list of Events and Alarms that are logged.

TABLE OF EVENTS/ALARMS LOGGED		
ALPHADOC OPTION	DNSTRM POWER FAULT	OUTPUT 2 TRIPPED
APP CARD CODE DOWNLOADED	HIGH BATT VOLTS	OUTPUT FAILURE
APP CARD HARDWARE STATUS	HIGH BATTERY ALARM	OUTPUT OVERLOAD
APP CARD REAL TIME CLOCK SET	HW COMPATIBILITY	OUTPUT OVERLOAD ALARM
APP CARD RESET CAUSE	INPUT FAILURE	PDB EEPROM ERROR
APP CARD TECHNICIAN CODE ENTERED	INPUT FAILURE ALARM	POWER SUPPLY INPUT CURRENT LIMIT ALARM
APP OPTION	INPUT OVER CURR	REFRESH
BATT TEMP PROBE	INV EEPROM ERROR	SAG COMPATIBILITY
BATTERY EOD	INVERTER ALARM	SAG DELTA MEAN
BATTERY FAIL	INVERTER ENABLE	SAG NO HARNESS
BATTERY LOG CLEARED	INVERTER TEMP	SAG NOT CALIBRATED
BATT. TEMPERATURE PROBE STATUS ALARM	LINE ISOLATION	SAG OPTION
CHARGER ENABLE	LINE ISOLATION ALARM	SAG RELAY STUCK
CHARGER FAIL ALARM	LOW BATT VOLTS	SELF TEST ALARM
CHARGER FAILURE	LOW BATTERY SHUTDOWN ALARM	SELF TEST FAIL
CLOCK NOT SET	MAJOR APPLICATION ALARM	SELF TEST FAIL ALARM
CM IP ADDRESS	MINOR APPLICATION ALARM	STR X MISWIRED
CM MAC ADDRESS	NO BATTERIES	SURGE MOV FAIL
CONFIG ERROR	OUTPUT 1 ENABLE	TM COMPATIBILITY
CONFIGURATION LOG CLEARED	OUTPUT 1 TRIPPED ALARM	X BAL STAGE
CPE IP ADDRESS	OUTPUT 1 TRIPPED	
CPE MAC ADDRESS	OUTPUT 2 ENABLE	

Table 3-4, Logged Events and Alarms

This is an example event log screen shot. The "EL" denotes the event log, and the record was time stamped on February 6, 2012 at 8:38:33 in the morning.

The up and down arrow keys step through the log records forward and backward in time.

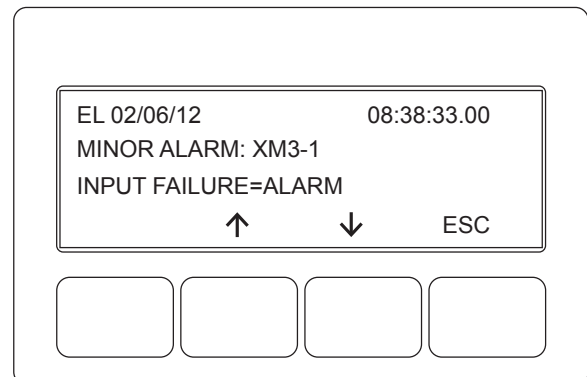

3.0 Operation, Continued

Battery Logging App:

This application allows the operator to manually enter the battery manufacture dates and their conductance (Mhos) values.

1. To enter the battery manufacture dates, press the BATT softkey on the XM3 main menu.
2. Next select the BATT CONFIG sub-menu.
3. Scroll the screen using the arrow keys until BATT DATES appears at the top of the screen.
4. Press the ENTR softkey. The APP card will now take over control of the display and show a list of installed batteries.

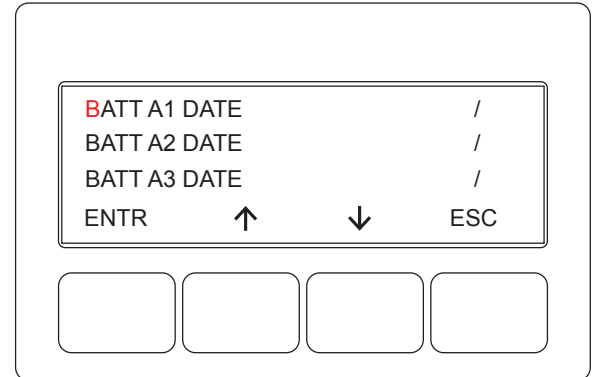

5. If the dates have never been entered, they will appear blank as shown. Use the arrow softkeys to select the appropriate battery.
6. To enter the manufacture date, press the ENTR softkey. The following screen will appear.
7. Use the up and down arrow softkeys to set the month.
8. Press the ENTR softkey to select the year adjustment.
9. Press the ENTR softkey when finished.

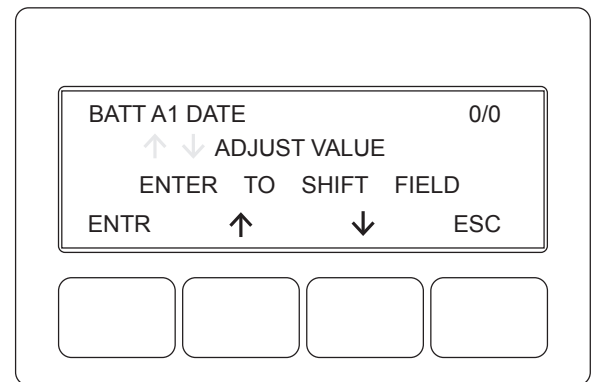

Note: The APP card will not allow a manufactured date set to a time after the current APP card date.

As a time saving feature, if battery dates have never been entered into the APP card, it will copy the entry for battery A1 to all batteries if A1 is done first.

When a battery date has been saved, the APP card will create a battery log record recording the date and time of the entry and the battery manufactured date for this battery.

3.0 Operation, Continued

Entering Battery Mhos:

To enter the battery MHOS reading, press the BATT softkey on the XM3 main menu. Next select the BATT CONFIG sub-menu. Scroll the screen using the arrow keys until BATT MHOS appears at the top of the screen. Press the ENTR softkey. The APP card will now take over control of the display and show a list of installed batteries.

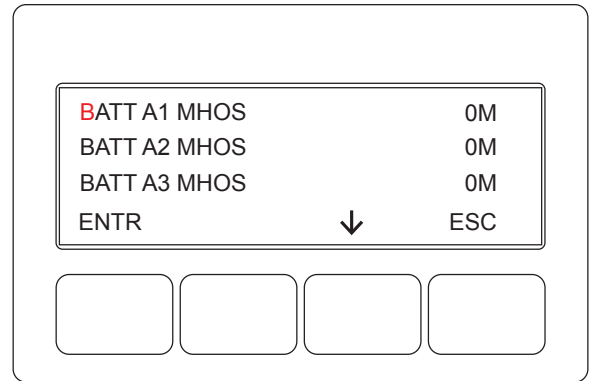

Use the softkeys to select the appropriate battery.

To enter the MHOS value, press the ENTR softkey. The following screen will appear.

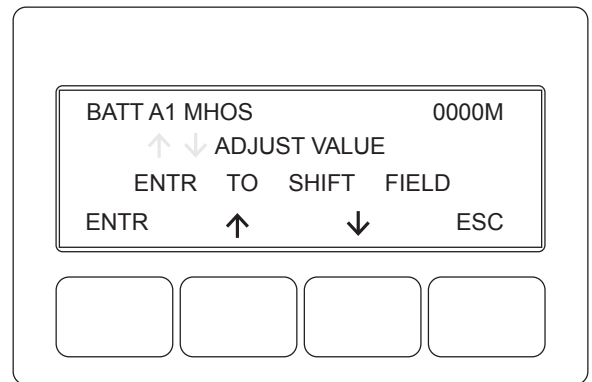

Use the arrow keys to select the flashing digit value. Press the ENTR softkey to move to the next digit, and so on. When all digits have been entered, the units will flash. The display will show the entered mhos value and the temperature compensated value. The PTS probe temperature is used for temperature compensation.

Press the ENTR softkey one more time to save the value.

Only the temperature compensated value will be logged or displayed from this point forward.

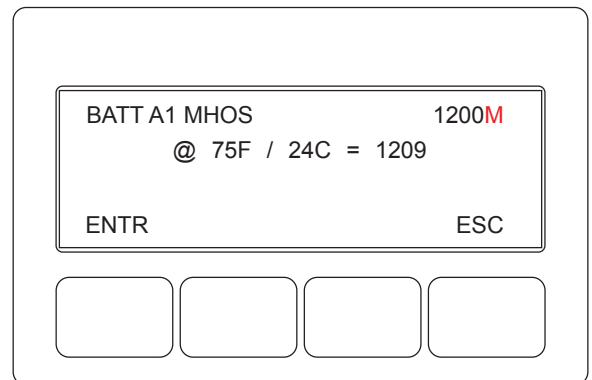

3.0 Operation, Continued

Battery Log Screen:

To enter the Battery History screen, select the APPS menu from the main XM3 screen. Bypass the Technician ID screen if needed and scroll up or down until BATTERY HISTORY is at the top of the scroll area.

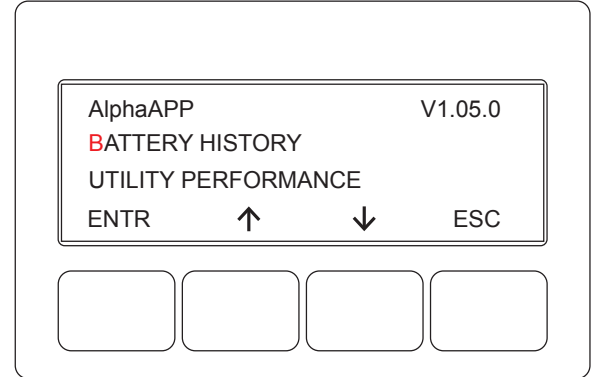

Press ENTR to access the BATTERY HISTORY screen:

The top three lines of the display scroll up and down using the arrow softkeys.

The “BL” in line one indicates the Battery Log. Also in line one is the date and time the record was created.

Line two has the battery name and the manufactured date stored.

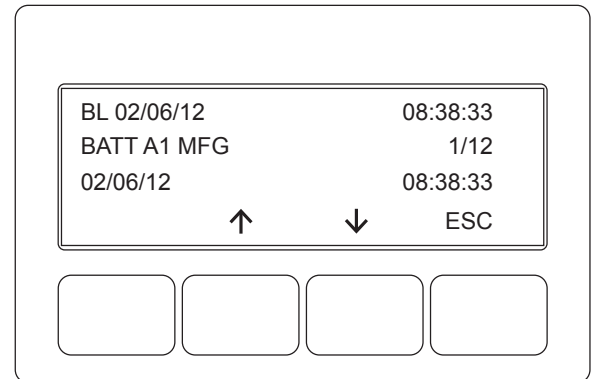

There are also battery MHOS records stored in the battery log.

The format of the record matches the battery dates record.

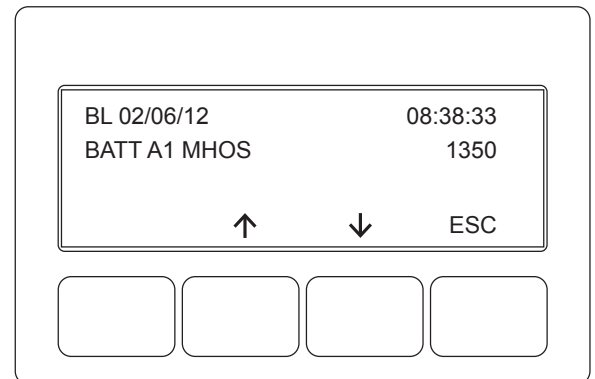

3.0 Operation, Continued

Utility Performance App:

This application monitors the AC line input to the XM3 power supply. It detects, displays and logs four types of AC fault conditions:

1. Outage – If the AC input is below a factory set threshold, an outage condition is recorded.
2. Sag – If the AC input exists but is below a factory set threshold, a line sag condition is recorded.
3. Surge – If the AC input exceeds a factory set threshold, a line overvoltage or surge condition is recorded.
4. Frequency – If the AC line frequency exceeds the normally defined operating range, a frequency event is recorded.

Each condition is measured with one second resolution and will not be permanently logged until the event has ended. To enter the Utility Performance sub-menu, scroll up or down until UTILITY PERFORMANCE is at the top of the scroll area.

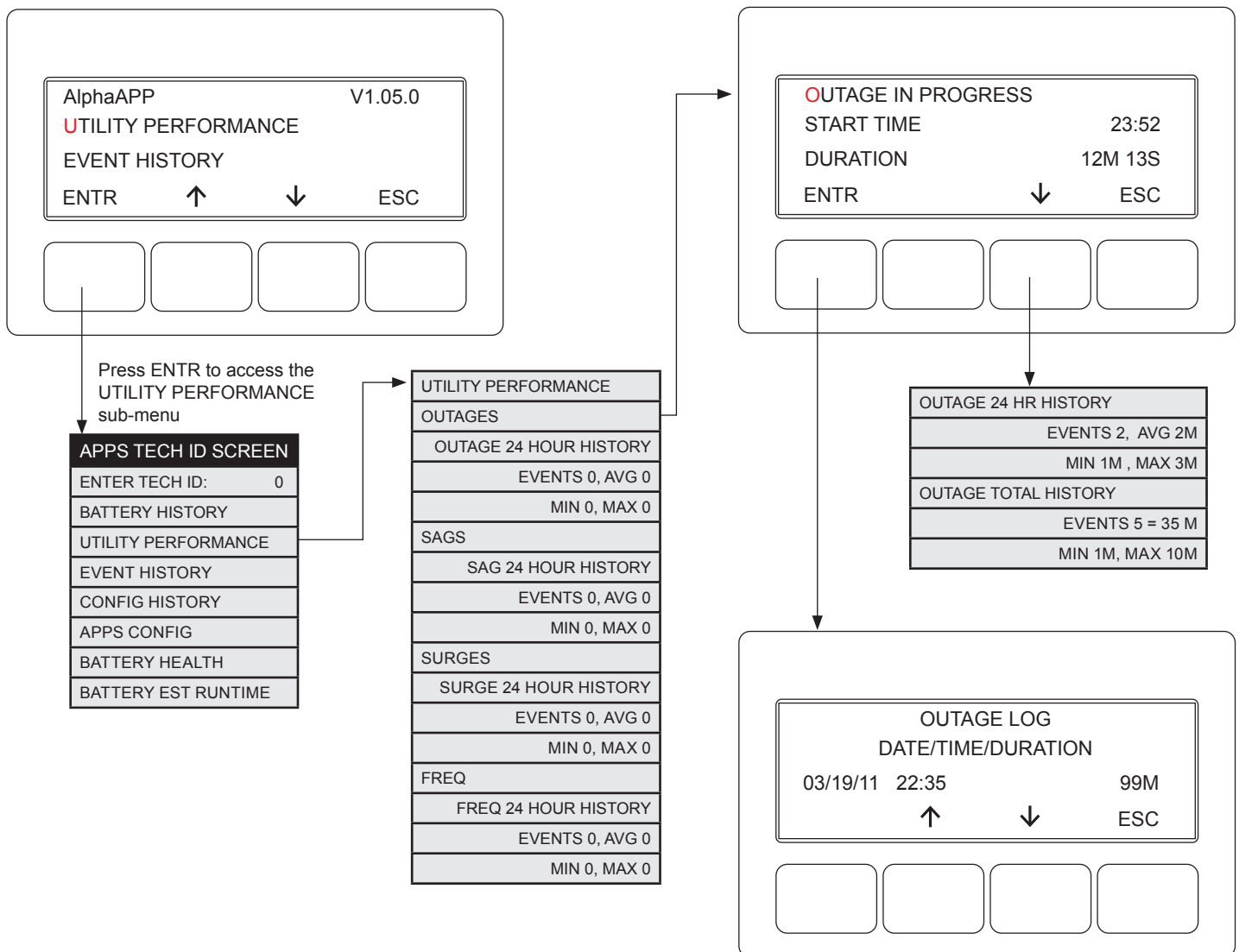

3.0 Operation, Continued

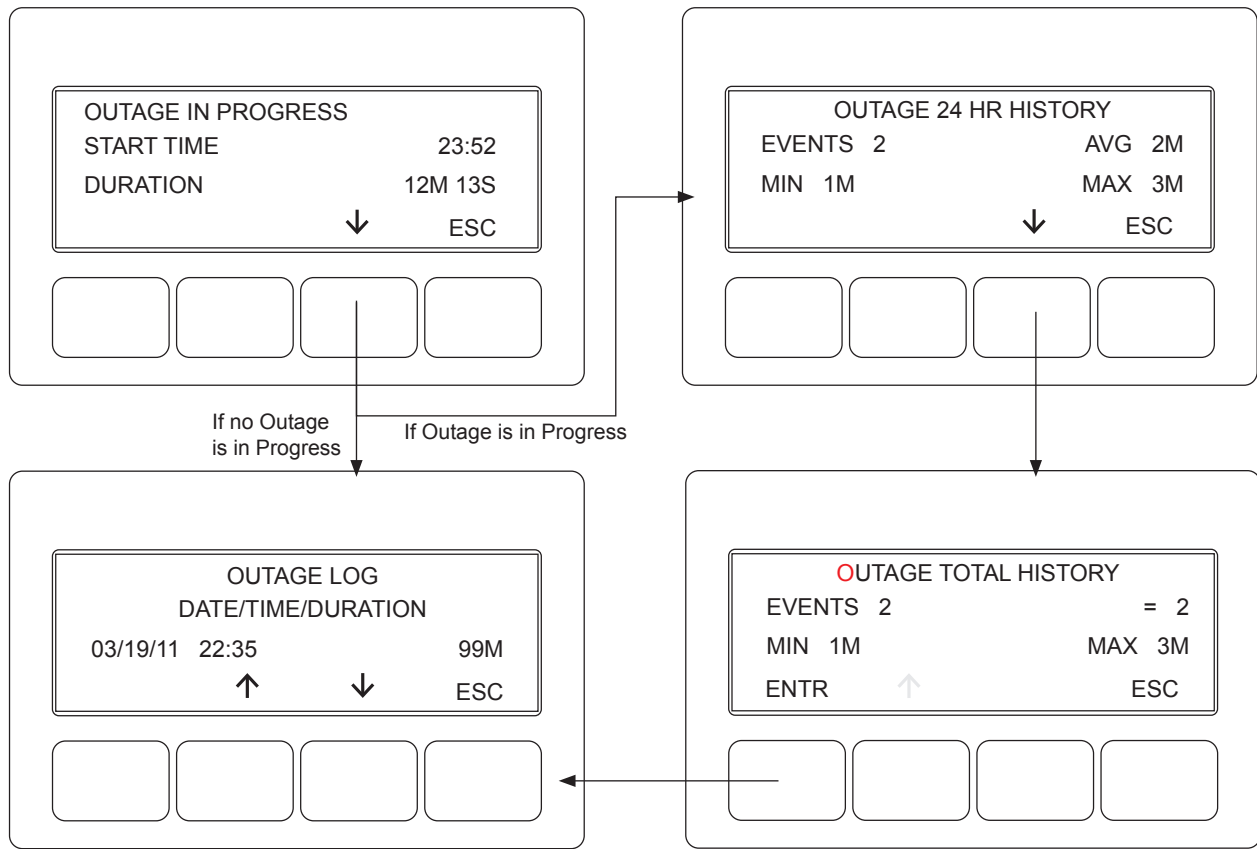

The top line of the Utility Performance sub-menu does not scroll. It indicates “OK” if there are no utility events active or “EVT” if there are.

Pressing the down arrow scrolls the sub-menu to show SAGS, SURGES and FREQUENCY sub-menu selections. Each of these sub-menus has the same structure as the OUTAGES sub-menu, so only OUTAGES will be shown here.

Press ENTR to select OUTAGES sub-menu (top left). This screen will appear if an Outage is in progress (top right), otherwise the screen below it will appear.

If any previous outages have been logged, the ENTR key will appear and the first character in OUTAGE will flash. Pressing ENTR displays the Outage Log.

Pressing the up and down arrows displays the various log entries. The last complete Outage logged will be displayed first. Press the down arrow to review earlier log entries.

3.0 Operation, Continued

Battery Health App:

The battery health application uses several factors in determining the remaining life of the batteries. Battery Manufacture date, install date, battery model, and other environmental conditions are key inputs to this algorithm.

To enter the Battery Health sub-menu, scroll up or down until BATTERY HEALTH is at the top of the scroll area.

Press ENTR to access the BATTERY HEALTH sub-menu.

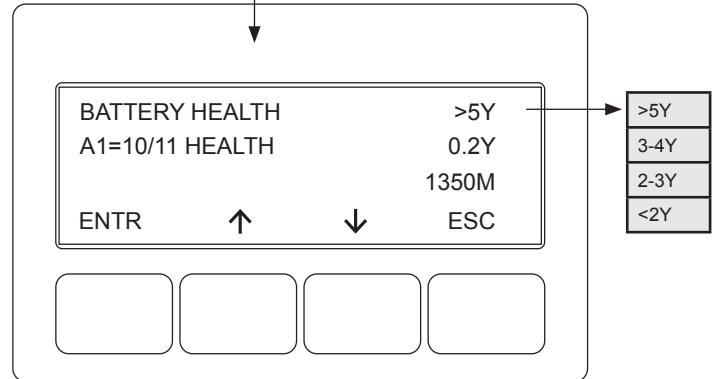
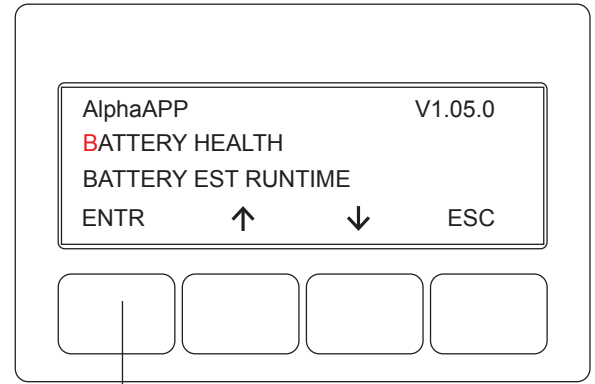

The top line of the BATTERY HEALTH sub-menu does not scroll. It indicates the remaining expected life of the battery set.

The second and third lines scroll together using the up and down arrow keys.

Line two contains the battery number (String A, B, C) and number (1, 2, 3). Battery A1 is the 12V battery on string A. Line two also contains the battery manufactured date and the calendar age of the battery.

Line three contains the temperature compensated MHOS value. The temperature compensated value is computed using the PTS.

3.0 Operation, Continued

Battery Run Time App:

The battery run time app dynamically computes the amount of standby time remaining in the batteries. It uses the existing capacity of the batteries, the AC load, the power factor and other environmental parameters.

The computed value is displayed on the power supply display, transponder Web page, and Alpha status monitoring systems. When a power supply is first installed, the display will indicate calculating to the transponder Web page and Alpha status monitoring systems until the first Self Test is run.

To enter the Battery Runtime sub-menu, scroll up or down until BATTERY EST RUNTIME is at the top of the scroll area.

Press ENTR to access the BATTERY RUNTIME sub-menu.

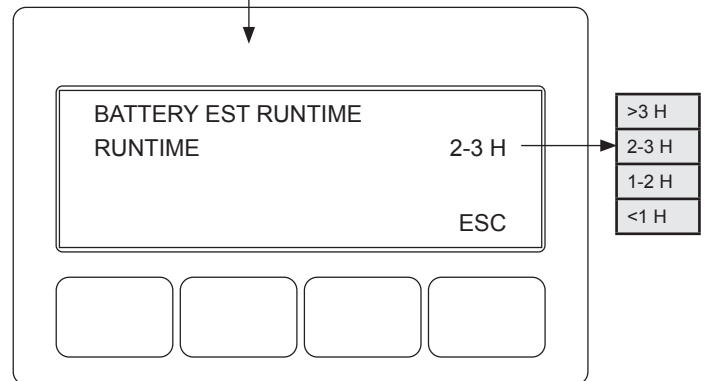
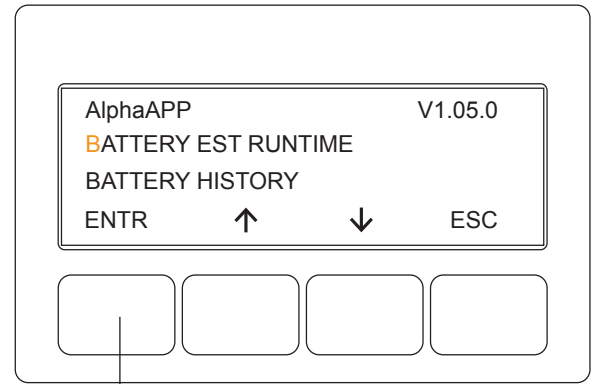

3.0 Operation, Continued

3.5 Active Alarms

Two LEDs on the Inverter Module indicate the condition and status of the Intelligent CableUPS.

- 1 The green Output LED, when lit, indicates the power supply is functioning normally and supplying output AC to the load. A flashing output LED indicates that an alarm has been detected. If there is an output failure, the Output LED will be turned off with hazardous output voltage present.
- 2 The red Alarm LED flashes to indicate a major alarm has been detected. This state clears when the alarm is no longer present. Under typical operating situations, the red Alarm LED is off. This indicates normal power supply operation.

In the event of a failure, the Active Alarm displays which alarms are active and how to correct the alarm condition. If the display is not illuminate, press a softkey to activate the display to view the alarm details.

- Press the menu key with ALM indicated above it to see the ACTIVE ALARM list for the selected key.
- Press UP or DOWN to select the alarm of interest.
- Press ENTR to select the alarm and display diagnostic information. Press ESC to return to the alarm list.

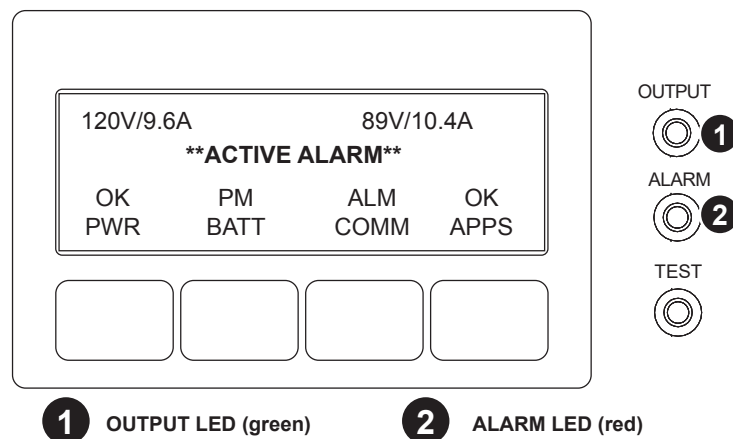

1 OUTPUT LED (green) 2 ALARM LED (red)

Condition	Output	Alarm
Normal	On	Off
Minor	Flash	Off
Major	Flash	Flash
Output Off	Off	Flash

Fig. 3-4, Active Alarm Table

(Alarm Conditions exist in the Battery and Communications subsystems)

A Help sub-menu provides possible remedies relating to the active alarm. To access the Active Alarm Help sub-menu, scroll to the alarm of interest and press ENTR. Press either UP or DOWN to scroll through the list of remedies.

Alarms are classified in two categories:

MAJOR Alarms are indications of a serious failure within the power supply, such as a loss of output voltage or a failed battery charger. Any situation that causes output failure is considered a Major Alarm. Major Alarms require immediate action to correct the failure. To correct Major Alarms, follow the Smart Display on-screen instructions.

MINOR Alarms indicate a less serious failure, such as defective PTS or loss of utility power. Corrective action can be delayed for a short time. To correct, follow the Smart Display on-screen instructions.

The alarm matrices on the following pages indicate the MAJOR/MINOR active alarms, the probable cause, troubleshooting items to check to correct the alarm condition, and whether or not Standby is disabled for that alarm type.

3.0 Operation, Continued

3.5.1 Menu Structure/Navigation (from Active Alarms Screen)

Sample alarm screens are shown for PWR, BATT, and COMM menus. Pressing the ENTR softkey in any of these screens will open the diagnostics screen for the alarm condition shown on the 3rd line of the screen.

The alarm condition will advance to the top of the screen and the second line will scroll through a listing of probable causes. Pressing ENTR will open a diagnostic screen of the suggested fixes.

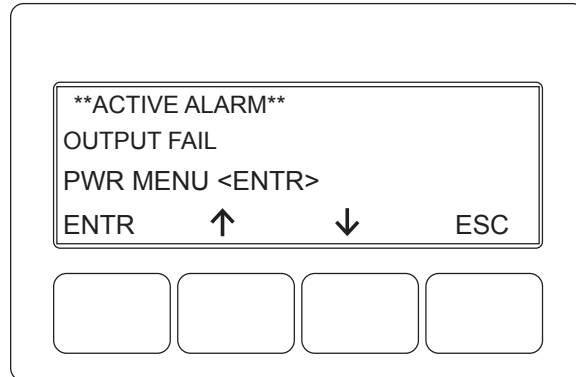

Fig. 3-5, Sample Active Alarm Display, PWR Menu

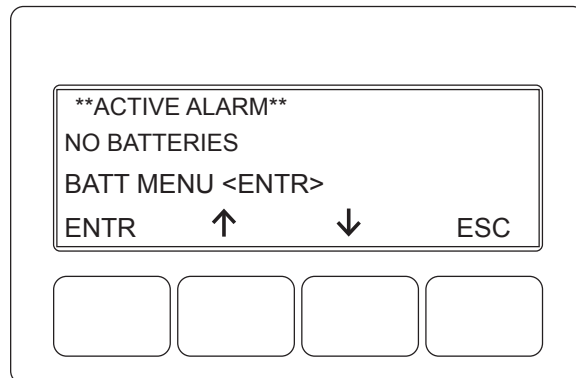

Fig. 3-6, Sample Active Alarm Display, BATT Menu

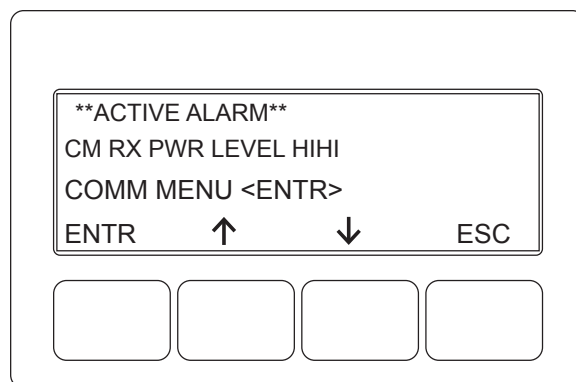

Fig. 3-7, Sample Active Alarm Display, COMM Menu

3.0 Operation, Continued

3.5.2 PWR Alarms

The Alpha XM3-HP CableUPS detects alarms and displays the type of active alarm in the Smart Display screen and the severity of alarm (e.g., Major/Minor) by means of the Inverter Module LEDs (see Table 3-4).

Active Alarm	Alarm Type	Alarm Category	Probable Cause of Alarm	Corrective Action	Standby Disabled
SELF TEST FAIL	Major	PWR	Output voltage failed or batteries less than 1.85V/C during Self Test.	1. Check Batteries 2. Check Inverter	NO
LINE ISOLATION	Major	PWR	Line isolation has failed and Inverter operations are suspended.	1. Replace power supply as soon as possible	YES
OUTPUT FAILURE	Major	PWR	The AC output has failed due to a bad Inverter or transformer, or an unstable transformer.	1. Apply load >1.5A 2. Output Overloaded 3. Check Inverter 4. Check Battery String	NO
OUTPUT OVERLOAD	Major	PWR	The output is overloaded or shorted.	1. Output Short Circuit 2. Check Output Current	NO
OUTPUT 1 TRIPPED	Major	PWR	Output 1 AlphaDOC hardware protection mode is engaged and overloaded.	1. Over Current 2. Check Settings	NO
OUTPUT 2 TRIPPED	Major	PWR	Output 2 AlphaDOC hardware protection mode is engaged and overloaded.	1. Over Current 2. Check Settings	NO
CHARGER FAILURE	Major	PWR	Charger has failed to shut down; possible battery over temperature condition exists.	1. Re-seat Inverter 2. Perform Self Test	NO
INVERTER TEMP	Major	PWR	Inverter heat sink has exceeded set temperature. (Stand-by operations suspended until temperature drops to a safe level.)	1. Check Inverter 2. Check PDB 3. Check Enclosure Ventilation	NO
CONFIG ERROR	Major	PWR	The power supply is improperly configured and operation is suspended until error is corrected.	1. Wrong Input Voltage or Frequency 2. Wrong Battery String	NO
INVERTER ALARM/ INVERTER FAILED	Major	PWR	No output detected with good batteries for 30 seconds OR inverter is disconnected from PDB.	1. Re-seat Inverter 2. Replace Inverter	YES
N+1 IN USE	Major	PWR	Redundant in use	1. Check Output 2. Check Connections	NO
INPUT FAILURE	Minor	PWR	Utility AC input has failed.	1. Utility Failure 2. Check Input Breaker 3. Input Connections	NO
INPUT OVER CURR / INPUT CURRENT LIMIT	Minor	PWR	AC Input current exceeds threshold setting.	1. Reduce Output Load 2. Check Input Current Limit Setting	NO
SURGE MOV FAIL	Minor	PWR	The MOV board surge protection has failed and needs to be replaced.	1. Replace MOV board (see page 97 for further instructions)	NO
ALPHADOC OPTION	Minor	PWR	I2C has failed between XM3 and DOC.	1. Check Ribbon Cable 2. Replace DOC	NO
INVERTER ENABLE	Minor	PWR	System controller has disabled the Inverter	1. Check Inverter	YES
CHARGER ENABLE	Minor	PWR	System controller has disabled the charger	1. Check Charger	NO
APP OPTION	Minor	PWR	I2C has failed between XM3 and APP.	1. Check Ribbon Cable 2. Replace APP	NO
INV EEPROM ERROR	Minor	PWR	There has been an error reading the EEPROM on the inverter board.	1. Replace Inverter	NO
HW COMPATIBILITY	Minor	PWR	There is a hardware incompatibility between the Main micro board and the inverter board.	1. Check Micro Board 2. Check Inverter Board	NO
PDB EEPROM ERROR	Minor	PWR	There has been an error reading the EEPROM on the PDB.	1. Replace power supply	NO

Table 3-5, PWR Alarms: Classifications, Causes and Corrections

3.0 Operation, Continued

3.5.3 BATT Alarms

The Alpha XM3-HP CableUPS detects battery alarms and displays the type of active alarm in the Smart Display screen and the severity of alarm (e.g., Major/Minor) by means of the Inverter Module LEDs.

Active Alarm	Alarm Type	Alarm Category	Probable Cause of Alarm	Corrective Action	Standby Disabled
NO BATTERIES	Major	BATT	Detected the absence of batteries (alarm inactive when battery capacity or number of battery strings is set to 0).	1. Check Batt Breaker 2. Check Connections 3. Check Battery Fuse	YES
LOW BATT VOLTS	Major	BATT	Battery voltages below 1.833V/cell.	1. Check AC Input 2. Restore AC Input 3. Connect Generator 4. Check Battery String	NO
HIGH BATT VOLTS	Major	BATT	Battery voltages above 4.5V over target charger voltage.	1. Check Batteries 2. Replace Inverter	NO
BATTERY EOD	Major	BATT	Batteries dropped below the low voltage shutdown level.	1. Low Battery Disconnect	YES
BATTERY FAIL	Major	BATT	Charge current > 5.0A for 7 days while in float mode.	1. Check Batteries 2. Replace Batteries	NO
BATT TEMP PROBE	Minor	BATT	Precision Temperature Sensor (PTS) failed or is not installed.	1. Check Connection 2. Replace Sensor	NO
REFRESH/BATT REFRESH ALARM	Minor	BATT	Battery Temperature Exceeded 60°C.	1. Check Charger Settings 2. Check Batteries 3. Check Battery Temperature	NO
SAG OPTION	Minor	BATT	I2C has failed between XM3 and SAG.	1. Check Ribbon Cable 2. Replace SAG	NO
SAG DELTA MEAN	Minor	BATT	Battery voltage is either too high or low from mean.	1. Check Batteries 2. Replace Batteries	NO
SAG RELAY STUCK	Minor	BATT	Relay has stuck or 36V or 0V wire is no longer connected.	1. Check SAG Wires Battery 2. Check SAG Wires Unit 3. Replace SAG	NO
SAG FUSE PROTECTION	Minor	BATT	SAG option has been temporarily disabled due to degraded battery string	1. Check condition of batteries	NO
STR X MISWIRED	Minor	BATT	Battery wires are not connected properly or battery voltage is outside valid range of 9.9V to 15.7V.	1. Check SAG Wires Battery 2. Check SAG Wires Unit 3. Replace SAG Wires	NO
SAG NOT CALIBRAT	Minor	BATT	Calibration data is not or is no longer available.	1. Replace SAG	NO
X BAL STAGE	Minor	BATT	Stage 0 and 1 are normal. Stage 2 shows that the batteries are not of similar capacity. Stage 3-5 trigger check battery alarm to show that there is a major capacity imbalance.	1. Check Batteries 2. Replace Batteries	NO
SAG NO HARNESS	Minor	BATT	Battery wires are not connected properly.	1. Check SAG Wires Battery 2. Check SAG Wires Unit 3. Replace SAG Wires	NO
SAG COMPATIBILITY	Minor	BATT	1. The SAG type installed does not match the XM3 model battery string voltage 2. Battery type not supported by SAG (such as XTV 18V4)	1. Replace SAG 2. Remove SAG	NO
COM COMPATIBLTY	Minor	BATT	The status monitor (comm) card is not compatible with the XM3 power supply.	1. Replace Comm	NO

Table 3-6, BATT Alarms: Classifications, Causes and Corrections

If desired, the No Battery alarm can be disabled by changing the Number of Battery Strings or Battery Capacity to “0” in the BATT CONFIG menu.



NOTICE:

Setting the number of strings or capacity to 0 will disable the inverter, and the unit will no longer have backup capability. When installing batteries, set the number of batteries and the battery type or battery capacity to enable battery charger and allow the XM3 to go into Self Test and Standby.

3.0 Operation, Continued

3.5.4 COMM Alarms

The Alpha XM3-HP CableUPS detects communication alarms and displays the type of active alarm in the Smart Display screen and the severity of alarm (e.g., Major/Minor) by means of the Inverter Module LEDs.

Active Alarm	Alarm type	Alarm Category	Probable Cause of Alarm	Corrective action	Standby Disabled
RF POWER LVL FAULT SEE GENERAL MENU	Minor	COMM	RF receive and/or transmit power levels are outside of optimal thresholds	1. Check attenuation 2. Adjust RF padding	NO

Table 3-7, COMM Alarms: Classifications, Causes and Corrections

3.5.5 APP Alarms

The Alpha XM3-HP CableUPS detects and initiates an alarm if certain parameters for Applications are not met. See Table 3-7 for APP Alarms.

Active Alarm	Alarm type	Alarm Category	Probable Cause of Alarm	Corrective action	Standby Disabled
CLOCK NOT SET	Minor	APP	Real time clock not set	1. Set real time clock	NO

Table 3-8, APP Alarms: Classifications, Causes and Corrections

3.6 Smart Display Glossary

Battery Capacity: The capacity of the battery strings attached to a particular Intelligent CableUPS. When batteries are not attached, the setting must be programmed to “0.” This disables standby operations, including test mode, and disables the No Batteries Alarm. If batteries are attached, then this setting should be programmed to the rating of each battery. If the power supply is used in a non-standby application, the Battery Capacity variable must be programmed to “0” to disable the battery maintenance cycle portion of a Self Test.

Battery Dates: The month and year the batteries were manufactured can be entered here. This value is hidden if the APPs card is not installed.

Battery MHOs: The conductance measurement of the batteries. The date of each entry is also recorded. This value is hidden if the APPs card is not installed.

Battery Model: The AlphaCell battery type can be specified in the Smart Display (if not AlphaCell, leave as default battery type, Other). If AlphaCell is selected, parameters for Accept, Float, Temp, Comp and Battery Capacity are automatically selected. If Other, these parameters will need to be manually set to the manufacturer’s recommended rating.

Battery Strings Detection Type: Select AUTO to have the power supply automatically detect the number of battery strings connected (via SAG or DSM harness). Set to MANUAL to manually override the sensed value or if no harness is connected.

Battery Temperature: The temperature of the batteries sensed from the PTS connected to the front of the inverter.

Battery Voltage: The total battery string voltage.

Charger Accept Voltage: Battery Accept charge voltage control in volts per cell. This voltage, 2.40VDC (adjustable for OTHER battery types) per cell, is temperature compensated to ensure longer battery life. It properly completes the charge cycle and is factory set for AlphaCell batteries. If another manufacturer’s batteries are used, consult the battery manufacturer for Accept voltage levels.

Charger Current: The battery charger current in Amps. When running in Standby mode, this value will display “Batt Current” which is the battery discharge current in Amps.

Charger Float Voltage: Battery Float charge voltage control in volts per cell. The average is approximately 2.27VDC (adjustable for OTHER battery types) per cell. It is factory set for AlphaCell batteries. If another manufacturer’s batteries are used, consult the battery manufacturer for Float voltage levels.

3.0 Operation, Continued

Charger Mode: The mode of the battery charger which may be one of the following: OFF, TEST, BULK, ACCEPT, REFRESH, FLOAT, REST.

Charger Temperature Compensation: Battery charger temperature compensation control. Programming this parameter to "0.0" disables temperature compensation. It is factory set for AlphaCell batteries (5mV/cell). If another manufacturer's batteries are used, consult the battery manufacturer for Charger Temperature compensation ranges.

CM IP Address: The IPV4 IP address assigned to the cable modem of the DOCSIS transponder.

CM IPV6 ADR Postfix: The last 4 sections of the IPV6 address of the cable modem when deployed on an IPV6 network. Refer to the previous menu item for the first 4 sections of the address.

CM IPV6 ADR Prefix: The first 4 sections of the IPV6 address of the cable modem when deployed on an IPV6 network. Refer to the next menu item for the last 4 sections of the address.

CM MAC Address: MAC (Media Access Control) address assigned to the cable modem. A MAC label is provided on the DOCSIS transponder. This item may also be labeled as the "RF MAC Address" on some DOCSIS transponders.

CM Receive Power: The RF receive (downstream) power at the cable modem. The acceptable range is between +15 to -15 dBmV. The ideal operating receive power is 0 dBmV.

CM Transmit Power: The RF transmit (upstream) power from the cable modem. The acceptable range is less than +55dBmV. The ideal operating transmit power is less than +50 dBmV.

Common Logical ID: Specifies the logical ID for the managed power supply used by network management systems. Some network management systems require this item to be blank. This item can be entered via the transponder Web page or status monitoring firmware.

CPE IP Address: The IPV4 IP address assigned to the CPE side of the DOCSIS transponder when used in Dual IP configuration.

CPE MAC Address: MAC (Media Access Control) address assigned to the CPE side of the transponder. A MAC label is provided on the DOCSIS transponder. The CPE MAC is utilized in Dual IP configurations.

Current Outage: When the power supply is operating in standby mode, this is a counter (in minutes) of how long the power supply has been in standby mode. This is not used for self-test events.

Device Address: The power supply must have a unique address to communicate with a system controller. The system controller uses the address as an identifier to query the power supply for information. Each power supply on the same communications bus must be identified with a value between 1 and 5.

Discharge Level: This is the setting for the amount of battery discharge to be performed during self-test, either manual or automatic. "TIMED" is the default and will use the time set in the Test Duration parameter. Deep discharge levels of 10%, 20%, 30%, 40% and 50% may be set. When set, the batteries will be discharged by the specified capacity percentage one time. Upon completion, the setting will revert back to Timed.

DOCSIS Config File: The file name of the cable modem configuration file the DOCSIS transponder has downloaded.

Downstream SNR: The downstream signal-to-noise ratio. A value less than 28 dB usually indicates a noise issue on the forward RF plant and the DOCSIS transponder may have issues communicating with the CMTS or status monitoring system.

DSM Firmware Version: The firmware version (4.4.9.0_03.02_NA) loaded on the cable modem microprocessor chip. The first half of the name is the Broadcom firmware (4.4.9.0) and the second half of the name is the Alpha firmware (03.02).

DSM Model/Config: The model and configuration (options) of the DOCSIS transponder. The model possibilities are DSM3, DSM3x, IDH4 and DPM/IDH4L. The common options are CW = Cableware (DSM3 series only), DP = Dual-IP (DSM3 series only) and RT = Reset Timer.

DSM Serial Number: The serial number of the transponder. A label is provided on the DOCSIS transponder.

End of Battery Discharge (EOD): The point at which the batteries are fully discharged (default 1.75V/C — GXL Series or "Other" batteries or 1.70V/C — HP Series batteries; 18 cells for 36V inverter) and the power supply shuts off, preventing permanent damage to the batteries.

EOD Type: Determines whether the low battery voltage cutoff is based on the battery string voltage measurement or the lowest individual battery voltage measurement.

EOD Voltage: The low battery (End of Discharge) voltage at which the inverter will shut off the output. This value can be programmed if the EOD Type is Individual. This line is hidden if the EOD Type is String.

3.0 Operation, Continued

Frequency Range Limit (setting may be increased when powering with AC Generator): AC input voltage frequency range limit. This limit establishes the acceptable input frequency range outside of which standby operation is initiated.

Heater Mat Installed: If a battery heater mat is installed, this value can be programmed to Yes. The information is then available for the headend.

IM #####: The serial number of the XM3 Inverter Module.

Individual Battery Voltages: List of the individual battery voltages measured from the battery sense harness from either the status monitor card or the Smart AlphaGuard.

Input Current Limit: The maximum allowable input current. When this limit is exceeded, the maximum battery charger current will be reduced to stay within this limit.

Input Current: The AC input current to the power supply.

Input Frequency: The frequency of the AC input voltage.

Input Power: The total input power in Watts

Input Voltage: The AC input voltage to the power supply.

Last Event: How long in days, hours and minutes (DDDD:HH:MM) since the last standby event ended. This does not include self-test events.

Last Outage: The time the power supply was in standby mode during the most recent outage. This does not include Self Test events.

Last Standby Reset: The number of days since the Total Standby Time and Events was reset.

N+1 Valid: Automatically sensed indication (Yes/No) whether a redundant voltage source has been connected to the N+1 connector on the DOC with N+1 option.

Number of Battery Strings: Enter the number of battery strings installed here. This value is used with the Battery Capacity setting to set some of the battery charger parameters if the Battery Strings Detection type is set to Manual.

Operating Mode: The operating mode of the power supply will indicate Line when it is powering the output from the AC utility or Standby when it is powering the output from the batteries.

Output 1 Current: The AC output current from Output 1 of the AlphaDOC. This value is hidden if the AlphaDOC is not installed.

Output 1 Overcurrent Trip level — Primary leg: Value of RMS current that causes an overcurrent trip on the Output 1 protection relay after a specified delay. This limit is linked to counter data item Overcurrent Tolerance Period. This parameter is only visible when the Protective Interface Module (AlphaDOC) is attached.

Output 2 Current: The AC output current from Output 2 of the AlphaDOC. This value is hidden if the AlphaDOC is not installed.

Output 2 Overcurrent Trip level — Secondary leg: Value of RMS current that causes an overcurrent trip on the Output 2 protection relay after a specified delay. This limit is linked to counter data item Overcurrent Tolerances Period. This parameter is only visible when the optional AlphaDOC (Alpha Dual Output Card) is attached.

Output Current: The total AC output current of the power supply.

Output Power: The total output power in Watts.

Output Voltage: The AC voltage at the output of the power supply.

Output Voltage Regulation Mode: The XM3 will be able to function in 2 modes of output voltage regulation: Fine and Coarse. When operating in Fine mode, the unit will maintain the tightest output voltage regulation possible. When set to Fine mode, the unit will automatically adjust to and from Coarse mode temporarily if a) The unit switches to inverter because of high/low line more than 2 times in a 60 day period or b) the unit switches tap relays more than 60 times in a 60 day period. The unit will then automatically adjust back to Fine mode if there are less than 2 inverter transfers for high/low line and less than 15 output tap switches in a 60 day period. When operating in Coarse regulation - Wider output voltage regulation window - Switches taps as few times as possible. Will never automatically adjust once it is selected. Both of these modes are user selectable in the PWR CNFG Menu.

3.0 Operation, Continued

Percent Load: The percentage of the output current versus the rated output current.

Power Supply Priority Level: The operator may select the power supply priority level in context of its deployed location in the cable network. This setting is a reference for the customers only and does not affect the power supply performance. The settings are Normal (default), High, or Critical.

PowerStave Mode: A mode of the SAG initiated by a "turn off" command from the power supply. In this mode the software disables the balancer including all relays, and it turns off all the LEDs. It only detects voltages on a query from the power supply.

REFRESH Enable: This enables a 24-hour REFRESH charge of the batteries. This is recommended for batteries that have been in storage.

Reset Standby: This resets the Standby Total and Standby Events.

REST Enable: Enables the REST battery charger mode. The value is read-only when Alpacell battery models are selected, and is programmable when the battery model is Other.

RMODE: An inverter control that limits the peak output voltage. When R-Mode is enabled the XM3 will reduce the inverter mode output peak voltage for powering legacy HFC equipment with lower peak input voltage tolerances. For 90VAC output RMODE, the XM3 inverter firmware version must be 1.09.0 or higher. For 60VAC output RMODE, a minimum inverter firmware version of 1.12.0 or higher is required.

SAG FW Vx.xx.x: The Smart AlphaGuard firmware version that is installed. This is hidden if the SAG is not installed.

SAG Option: Indication whether the Smart AlphaGuard is installed. This is automatically sensed.

SAG #####: The Smart AlphaGuard Serial Number. This is hidden if the SAG is not installed.

Self Test: When programmed to YES, the power supply automatically starts a Self Test. If the power supply is used in a non-standby application, the Battery Capacity variable must be programmed to "0" to disable the battery maintenance cycle portion of a Self Test.

Set Defaults: When programmed to YES, the programmable data levels (with the exception of Last Standby Time, Total Standby Time, Standby Events, Device Address, Total Run Time, Battery Type and Language) are reset to the original factory settings.

Set Language: The display text language can be set to English, Spanish, French, German, or Portuguese.

Standby Events: A standby events counter. This does not include Self Test events. Resetting factory defaults does not clear **Standby Events** or **Standby Total**.

Standby Total: The total amount of time the power supply has operated in standby mode. This does not include Self Test time and represents the sum total number of minutes of AC line failure since the last time the counter was reset. Resetting factory defaults does not clear **Standby Events** or **Standby Total**.

System Contact: The textual identification of the contact person for the managed power supply, together with information on how to contact this person. This item can be entered via the transponder Web page or status monitoring firmware.

System Location: The physical location of the power supply. This item can be entered via the transponder Web page or status monitoring firmware.

System Name: An administratively assigned name for the managed power supply. This item can be entered via the transponder Web page or status monitoring system.

Test Countdown: The number of days remaining before the next scheduled automatic Self Test initiates. This variable is programmable and you can select the day the autotest sequence will begin. This counter has no effect if test interval is set to 0.

Test Duration: Automatic Self Test duration timer. This sets the number of minutes of a battery maintenance cycle test. This timer applies to automatically or manually initiated tests.

Test Inhibit: Becomes active when programmed by the operator (or when the unit runs in inverter mode for more than 5 minutes). The power supply delays the start of a scheduled Self Test for seven days if the test countdown is less than seven days (See **Section 3.7, Automatic Performance Test** for complete details).

Test Interval: Automatic Self Test control timer. The number of days between battery maintenance cycle tests. Set this value to zero to disable automatic Self Test.

TM #####: The serial number of the XM3 transformer module.

Total Run Time: The amount of time (in days) the power supply has functioned in any mode of operation. This is not a resettable value.

XM3 FW Vx.xx.x: The firmware version of the XM3 micro board.

3.0 Operation, Continued

3.7 Automatic Performance Test

Automatic Self Test: An automatic Self Test is periodically performed to verify the state of the batteries and the inverter circuitry. The automatic test feature has several programmable parameters that determine the frequency and duration of automatic tests. A running test may be halted manually by pressing the TEST button a second time.

The automatic test feature is on by default. To turn auto-test off, change Test Interval to 0 days in the POWER CONFIG Menu. Auto-test may be enabled at any time by changing the test interval to any numerical value (excluding "0"). The default test interval is 30 days.

The test sequence process:

- Begins with a check to verify the batteries are attached and the battery circuit breaker is closed. If the batteries are discharged or not connected, the power supply does not attempt to operate in inverter mode, preventing a drop of the load.
- Next, the power supply switches to standby mode for a pre-programmed period. Successful completion of a test sequence indicates the unit is operating normally in standby mode, the battery voltage did not drop below a preset threshold and the output was stable throughout the test. Failure of test is indicated by a Self Test Fail alarm, which can be cleared by subsequently running a successful test for at least one minute.

In addition to automatic testing, the operator can manually initiate a Self Test. A running test may be halted at any time by pressing the Self Test switch on the front panel (below the OUTPUT and ALARM LEDS on the Inverter Module) or from the PWR CONFIG menu. The status monitoring card allows a Self Test to be initiated via the webpage as well.

Test Inhibit: The Test Inhibit command prevents an automatic test scheduled to occur in the next week. This command is useful if periodic maintenance of the power supply is scheduled close to the next scheduled automatic test.

Use this feature when inclement weather might cause a utility failure. The Test Inhibit command affects an automatic test scheduled to run in the next seven days. Multiple issues of the Test Inhibit command result in the deferral of the next automatic test until at least seven days after the last request. This command has no effect if an automatic test is not scheduled to take place in the next week. Starting a test manually overrides the Test Inhibit command.

3.0 Operation, Continued

3.8 Providing Power via Portable Generator or Inverter

In the event of an extended utility failure, an external AC or DC power source can provide backup power to the system. This backup power enables the power supply to continue charging the batteries ensuring uninterrupted service to the network. Follow the documentation and connection procedures listed below.

3.8.1 DC Powering

The AlphaGen Portable Generator provides a convenient method of providing backup DC power. Upon the loss of commercial AC power, the existing battery strings immediately supply voltage to the Inverter Module. After some point of battery discharge, a portable generator can be deployed to the site to supply power to the DC bus. For complete connection and operation information of the AlphaGen Portable Generator, refer its operator's manual (Alpha P/N 041-028-B0).

3.8.2 AC Powering

Should it become necessary to power the CATV system with a portable AC generator, truck-mounted AC generator or truck-mounted inverter, follow the procedures below for the protection of service personnel and powering system equipment.

Connection Procedure:

1. Read the Smart Display to determine if there is output power to the system. If there is still power to the system, check the battery voltage on the Smart Display:
 - If the battery voltage is greater than 34.5VDC, then approximately one hour remains to complete the changeover to generator power before the cable system loses power to its customers.
 - If the battery voltage is less than the previous numbers, move rapidly as there is not much time until the system fails. However, exercise caution as there are dangerous voltages in the system that can shock you or damage the cable amplifiers.
2. Verify the AC Input breaker from the utility powering system is in the OFF position. This ensures that if power returns suddenly, you will not experience a surge in power. This also ensures when the generator is connected it will not put AC voltage back onto the power lines.
3. Properly ground the generator by connecting a #6 AWG wire from the grounding lug on the output panel of the generator to either a driven ground rod or the strand ground on the pole to which the power supply is mounted. If working with a ground-mounted power supply, locate the grounding point inside the enclosure and clamp on to that point.



CAUTION!

Grounding the generator is *mandatory* for safety and for proper operation of the power supply.

3.0 Operation, Continued

4. After the generator is properly grounded, unplug the power supply from the convenience outlet inside the enclosure and plug the power supply input cable into the generator output. Use an outdoor rated approved extension cord. Recommend min 12 AWG for 120V, 14AWG for 240V installations.
5. Start and operate the generator according to the generator operation manual.
6. If the generator kilowatt rating is twice the kilowatts used by the power supply indicated on the Smart Display, leave the battery breaker on and the generator will charge the batteries. If the generator fails, the power supply will continue to provide battery backup. If the generator output is not approximately twice the kilowatt rating indicated on the Smart Display, switch the battery breaker OFF to reduce the load on the generator if battery backup of the system is unavailable.
7. In either case, after the power from the generator is applied to the power supply, use the Smart Display to increase the Frequency Input Tolerance to $\pm 6\text{Hz}$ from the normal $\pm 3\text{Hz}$, inhibiting the power supply from switching to battery backup if the generator occasionally does not operate on the proper frequency. It is not uncommon for smaller (4 kilowatt or less) sized generators to get "off frequency" due to the step loading of the power supply.



WARNING! ELECTRICAL HAZARD

Ground the vehicle before operating a truck inverter or truck-mounted generator. Failure to do so places service personnel at risk for electric shock.

3.8.3 Using a Truck-mounted Inverter or Generator

To use a truck-mounted inverter or generator, follow the steps listed in **Section 3.8.2, AC Powering** with the additional step of grounding the truck. Run the ground wire from an unpainted point on the truck chassis to either a driven ground rod or strand ground to complete the grounding circuit. The rubber tires on the truck insulate it from being grounded in all but the most exceptional circumstances.

3.9 Resumption of Utility Power



WARNING! ELECTRICAL HAZARD

Use caution when disconnecting and reconnecting a generator to utility power. Dangerous voltages are present.



CAUTION!

Exercise care to ensure that both of the powering systems are NOT connected at the same time or damage to the power supply and the generator may result.

1. Before turning on the AC voltage input breaker, use a voltmeter to verify the input voltage is within specifications.
2. When the proper voltage is present, verify the battery voltage indicated on the Smart Display is greater than 31.5VDC. Disconnect the power supply from the generator output and plug the power supply input cord into the convenience outlet within the enclosure. The power supply operates on battery backup for this short period of time, but exercise caution during this changeover as the grounding circuit to the power supply is broken.



NOTICE:

If the batteries are at or below the low voltage cutoff, then the power supply will NOT transfer to battery backup and there will be a momentary power outage to the cable system while you make this changeover.

3. Turn on the AC input power.
4. Shut down the generator and remove the grounding system. If necessary use the Smart Display to return the Frequency Input Tolerance back to the normal $\pm 3\text{Hz}$ range.



CAUTION!

- The power supply must be serviced by qualified personnel.
- Use heavy gloves when handling a unit that has recently been taken out of service. The ferroresonant transformer generates heat that may cause burns if handled with bare hands.
- Alpha Technologies is not responsible for battery damage due to improper charger voltage settings. Consult the battery manufacturer for correct charger voltage requirements.
- When removing batteries, ALWAYS switch the battery breaker OFF before unplugging the battery connector.
- Always wear safety glasses when working with batteries.

4.0 Maintenance

4.1 Safety Precautions

- Only qualified personnel should service the power supply.
- Verify the voltage requirements of the equipment to be protected (load), the AC input voltage to the power supply (line) and the output voltage of the system prior to installation.
- Equip the utility service panel with a properly rated circuit breaker for use with this power supply.
- When connecting the load, DO NOT exceed the output rating of the power supply.
- Always use proper lifting techniques whenever handling units, modules or batteries.
- The power supply contains more than one live circuit! Even though AC voltage is not present at the input, voltage may still be present at the output.
- The battery string, which provides backup power, contains dangerous voltages. Only qualified personnel should inspect or replace batteries.
- In the event of a short-circuit, batteries present a risk of electrical shock and burns from high current. Observe proper safety precautions.
- Do not allow live battery wires to contact the enclosure chassis. Shorting battery wires can result in a fire or possible explosion.
- This power supply has been investigated by regulatory authorities for use in various Alpha enclosures. If you are using a non-Alpha enclosure, it is your responsibility to ensure your combination conforms to your local regulatory requirements and the power supply remains within its environmental specifications.

4.2 Required Tools and Equipment

Prior to beginning maintenance, ensure that all required tools and equipment, including safety equipment, is available and functional.

The following is a list of the minimum equipment required to maintain and troubleshoot the XM3 power supply system and batteries:

- Digital voltmeter
- Socket wrenches, insulated
- Box end wrenches, insulated
- Torque wrench calibrated in inch/lbs
- Rubber gloves
- Full face shield
- Safety glasses
- Plastic apron
- Portable eyewash
- Spill kit, including sodium bicarbonate solution
- Fire extinguisher
- True RMS Volt Meter with DC Amp Clamp
- Midtronics Conductance Meter
- Optional equipment, depending on the type of maintenance being performed, includes:
 - Service power supply
 - 100 amp momentary load test set
 - System load bank (DC if to be performed at the battery and AC if to be performed by loading a power supply output— contact your Alpha Representative for more information).
 - No-Ox Corrosion Inhibitor
 - Paper towels and/or rags

4.0 Maintenance, Continued

4.3 Power Supply System Maintenance

4.3.1 Preparing for Maintenance

The power supply system should be remotely monitored and physically inspected periodically. If the system has an automatic monitoring system to gather the electrical and environmental data, the remote checks should consist of evaluating the recorded data and visiting any site that does not meet the specifications listed in the detailed procedures below.

Notify anyone affected by the intended maintenance or troubleshooting activity. This should include but not be limited to anyone responsible for the status monitoring equipment at the headend or NOC.

4.3.2 Periodic Maintenance Tasks

Remote Status Monitoring of Power Supply Monthly Self Test

The following maintenance procedure requires a fully functional status monitoring system capable of remotely measuring and recording the following data from a Self Test:

Self Test Result
Percent Load
Output Voltage

Procedure:

1. If Self Test fails a site visit is required
2. If the power supply percentage load is above 100%, a site visit is required
3. If Output voltage is below 84.5V for 89V units or 59V for 63V units, a site visit is required.

On-Site Power Supply Preventive Maintenance



CAUTION!

Ensure personal preventive equipment (including rubber gloves, plastic apron, safety glasses, and face shield) is worn prior to proceeding.

Procedure:

1. Exterior site inspection

- a. Inspect power supply cabinet security and condition.
- b. Inspect cabinet for integrity (securely mounted, service meter and conduit integrity, etc).
- c. Check all locks and hinges for proper operation and lubricate if necessary.
- d. Inspect integrity of ground wire and ground rod. Ensure wire is of acceptable gauge and proper connections are tight at both ends, meeting NEC or Local Authority specs.

2. Interior Cabinet inspection

- a. Remove any dust, debris, or rodent signs from enclosure, louvers or vents. If enclosure has filters, clean with compressed air or leaf blower.
- b. Check all interior locks, hinges and battery slide trays for proper operation and lubricate if necessary.
- c. Verify that SPI (ALT Box) is tight along with coaxial connection, ensuring that power supply and sheath of coax is grounded.
- d. Verify that power supply has a Surge Arrestor that is in working condition. Replace the unit as needed.

4.0 Maintenance, Continued

3. Power Supply Component Inspection

- Before physical inspection of the power supply, verify normal operation on the XM3 Smart Display. Clear all Active Alarms before proceeding.
- Check physical condition of power supply; remove any dust or debris built up in or around openings.
- Inspect all cabling and connections of the power supply system (see Fig. 4-1). Verify that all cabling is intact and all connectors are properly seated; resolve as needed.

- | | |
|--|--|
| 1 Battery Connector to Inverter | 8 AlphaDOC Dual Output Connectors |
| 2 Precision Temperature Sensor (PTS) connection point | 9 Local Remote Indicator (LRI) Mounting Location |
| 3 Negative Terminal to Center Battery and PTS | 10 LRI Connection to Power Supply |
| 4 Smart AlphaGuard Harness | 11 DSM3x/IDH4x Battery Sense Harness connection point |
| 5 Positive Battery Terminals to Smart AlphaGuard (3, Red) | 12 RF Connector/DM3/DSM3/IDH4 |
| 6 Negative Battery Terminal (1, Black) | 13 Tamper Switch |
| 7 APPs Card | 14 DSM3/IDH4 Tamper Switch Connector |

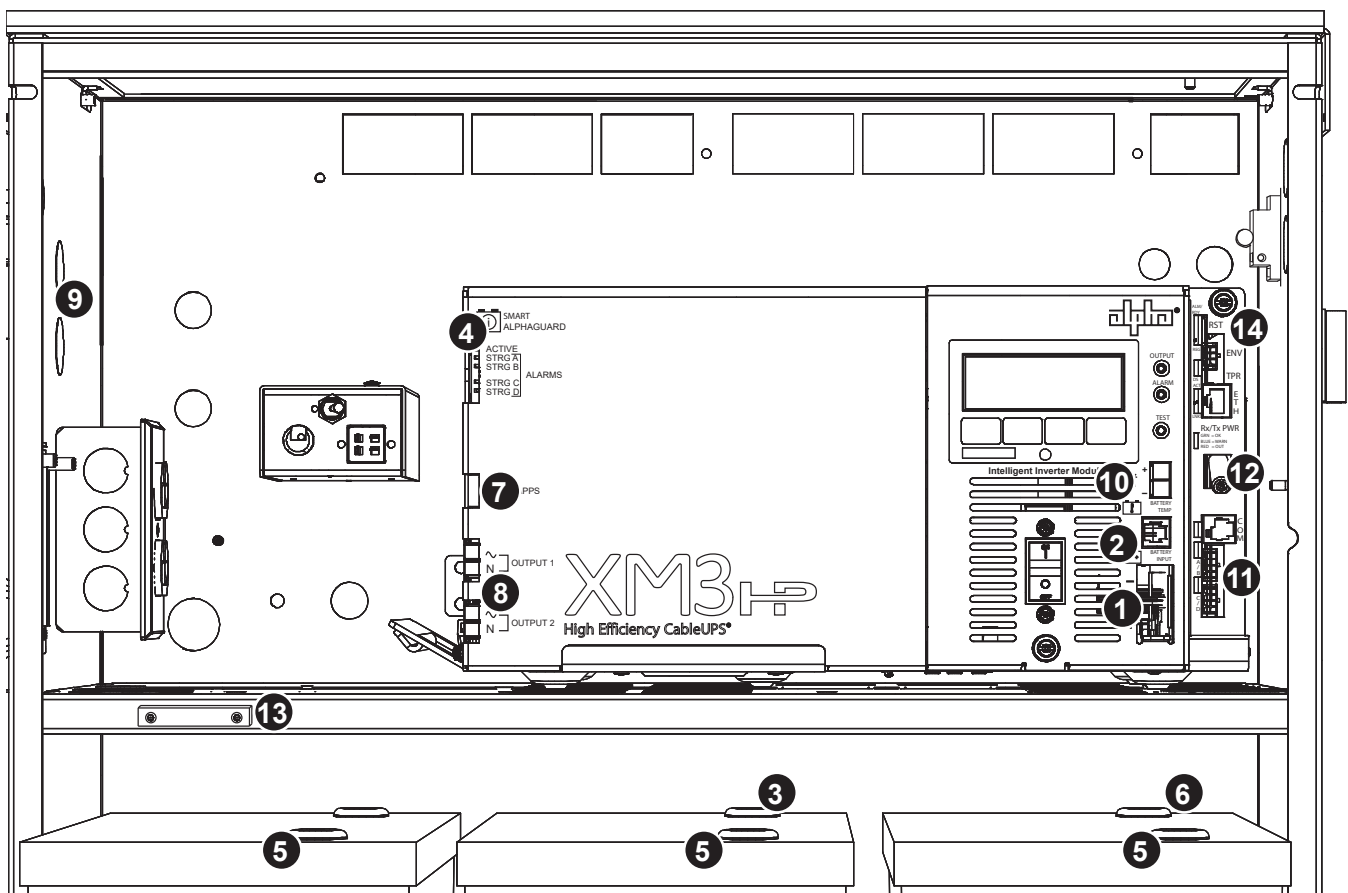

Fig. 4-1, XM3-HP System Components

4.0 Maintenance, Continued

4. Inspect Inverter Module



CAUTION!

Always switch the battery breaker OFF before removing or installing the Inverter Module assembly.



NOTICE:

Whenever the battery breaker is turned off or the batteries are not connected, the CableUPS automatically reports a No Battery alarm. This is a built in safety feature. The unit does not attempt inverter operations, either standby or test, during a No Battery alarm.



NOTICE:

You can remove the Inverter Module assembly while the power supply is running on line power. The power supply will continue to operate as a non-standby regulated power supply.

- a. Carefully remove the Inverter Module assembly.
 1. Shut off battery circuit breaker and disconnect the 36V battery cable from the Inverter Module.
 2. Disconnect the LRI and Temp Probe cables from the Inverter Module and the TMPR and XPDR cables from the communication module.
 3. Loosen the thumbscrews.
 4. Grasp tab at base of Communications Module sheet metal and pull Inverter Module from the power supply.
- b. Verify Output voltage remains with volt meter.
- c. Inspect the Inverter Module for signs of dust or corrosion.
- d. Reinstall the Inverter Module (reverse removal procedure) and test the power supply for proper operation.
 1. Turn off the utility input breaker to remove input power. The power supply goes into standby operation.
 2. Verify on the Smart Display that there is no interruption to the output.
 3. After five minutes reapply utility power. The power supply then transfers back to Operation Normal, clears any alarms and starts the battery charger (BULK, if needed.) This test adds standby events and time to the event counter.

5. Record the following data from the XM3 Smart Display and record in the XM3 system maintenance log:

Operational Data:

Output 1 Voltage	Output 2 Voltage (if AlphaDOC installed)
Output 1 Current	Output 2 Current (if AlphaDOC installed)
Input Voltage	Standby Events
Total Standby Time	Input Watts
Output Watts	PTS Reading
Outside Ambient	

4.0 Maintenance, Continued

4.3.3 MOV Board Replacement



CAUTION!

Always switch the battery breaker OFF before removing or installing the Inverter Module assembly.

Tools Required:

3mm slotted screwdriver

#2 Phillips-head screwdriver

Procedure:

1. Completely shut down the power supply; verify all power is removed. Ensure utility power is off and battery power is safely secured (or not installed) in the enclosure assembly. All connections and cables must be removed from the power supply. To maintain output to the load, consider using the APP9015S or APP9022S Service power supply when installing the MOV board.
2. Remove the inverter module.

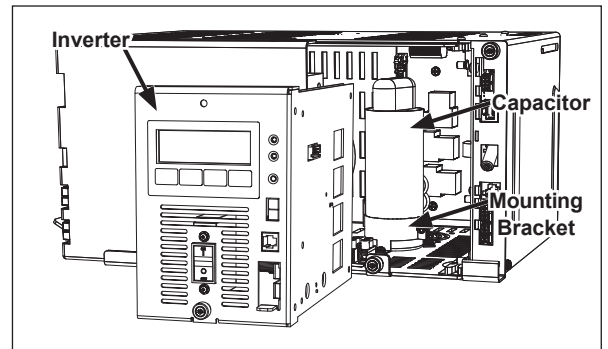

Fig. 4-2, Removing the Inverter

3. Loosen fastener, then remove the oil capacitor from its mounting bracket.
4. Remove the damaged MOV board from the PDB by pulling it firmly towards toward the capacitor mounting bracket.

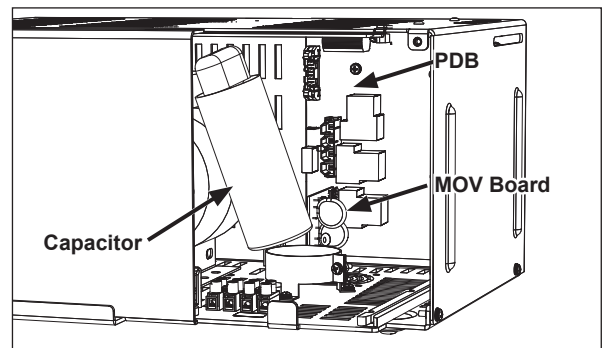

Fig. 4-3, Capacitor Removed from Mounting Bracket and MOV Board Location



NOTICE:

Be sure that the new MOV board has the same part number as the damaged board (-20 for 120V and -21 for 240V is critical).



NOTICE:

Align quick connects correctly, and ensure the MOV board is completely seated.

5. Install the new MOV board into the PDB.
6. Re-install the oil capacitor into its mounting bracket and tighten fastener.
7. Replace the inverter module.
8. Turn the unit back on and verify the Surge MOV Fail alarm has cleared.

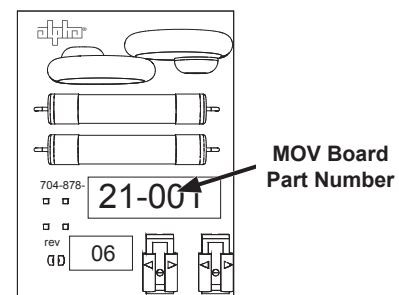

Fig. 4-4, MOV Board Model

4.0 Maintenance, Continued

4.4 PM Certification Report

Follow this sample when filling out the maintenance log (following page).



Site Data		DEMO				Site ID: EXAMPLE PM CERT			
Latitude		Longitude		Date	Feb. 05, 2014	Time	02:53 PM	Transformer #	
Hub		City		State / Province		Zip Code			
Region		System		Node		Country	USA		
Project ID		Street(s)		Address Notes		Pole #			
Business Service		Output VAC		120V Or 240V?		Powering A Node			
Utility Company		Utility Account #		Utility Meter #					
Transponder Data									
CM Mac Address		SNR		CER		Logic Card		Transmit Power	
CM IP Address		Transponder Type		Firmware Version		T3 Timeouts		T4 Timeouts	
SNMP TRAPS									
Trap 1		Trap 2		Trap 3		Trap 4			
Alpha MIB 1		Alpha MIB 2		Alpha MIB 3		Alpha MIB 4			
UPSTREAM									
Frequency		Modulation		Lock		Channel ID		Symbol Rate	
DOWNSTREAM									
Frequency		Modulation		Lock		Channel ID		Symbol Rate	
Power Supply #1 Data									
Make-Model		Date Code (MMYY)		Refurb Date (MMYY)		PIM/DOC Installed			
Firmware Version		Total Run Days		Controller Card		Serial Number			
Self-Test Duration (min)		Self-Test Interval (days)		Retry Limit		Retry Delay (Seconds)			
Event Log Cleared		Number Of Events		Events Time		Inverter Test Performed			
AC Input Voltage (VAC)		Output Voltage (VAC)		Output Current 1 (A)		Output Current 2 (A)			
Battery Data									
Self-Test Verified		Self-Test Start Time		Self-Test Finish Time		Battery Temperature (°F / °C)			
Battery #	Battery Manufacturer	Date Code (MMYY)	ID #	Voltage No Load (VDC)	Voltage Under Load (VDC) After 9 Minute Self-Test	BS Conductance (mhos)			
						Meter Reading	Corrected 77°F		
A1									
A2									
A3									
A4									
Battery Separator Present		String A Total				String A Fused			
B1									
B2									
B3									
B4									
Battery Separator Present		String B Total				String B Fused			
CHARGER INFO									
Charger Mode		Current (A)		Accept (V/C)		Current Limit (A)			
Float (V/C)		Temp Comp (mV/C°C)							

Fig. 4-5, PM Certification Report, Page 1



PM CERTIFICATION REPORT

INSTALL | MAINTAIN | REPAIR | VALIDATE



<i>As-Found Local Power Supply Alarms</i>			<i>Exceptions</i>
Alarm	Major/ Minor	Cleared On Site	Exceptions

<i>Inspection</i>					
Enclosure Exterior Maintenance Checklist					
Item To Check	Yes/No	Item To Check	Yes/No	Item To Check	Yes/No
Check For Pad Undermining		Clean Dust/Dirt From Enclosure Inside		Enclosure Hardware Tightened	
ACI Installed & Functioning		LRI Installed & Functioning		Enclosure Snow Shield	
Generator Accessibility		PS Co-Locate With Node		Control Switch Installed	
Co-Locate With Vault		U-Guard On Ground Wire		PS Metered	
Lock Present		Security Bar Present			
Enclosure Make-Model		Enclosure Condition		Enclosure Depth (cm)	
Internal Breaker		Service Entrance		Receptacle Type	
Dual Utility Switch Present		UG Or Aerial			
Interior Systems Maintenance Checklist					
Item To Check	Yes/No	Item To Check	Yes/No	Item To Check	Yes/No
Check Wire Harness And Connectors		Clean And NO-OX Batteries		Site Grounded Properly	
Tamper Installed And Functioning		AC TVSS Installed And Functioning		AlphaGuard Installed And Functioning	
Battery Hardware Properly Tightened		Coax TVSS Present		Battery Temperature Probe Present	
Pad Value		Cable Sim Value		Ground Current (mA)	
Tap Installed		Drop Installed		Generator Cord Present	
Battery Heater Mat Types & Quantities					
Mat Type	Quantity	Mat Type	Quantity		

<i>Work Items Performed On Site</i>		
Work Item	Quantity	Part Number(s)

<i>Technician Info</i>			
Open Items For Repeat Visit			
Initial X-Tractor & Form Time (minutes)	1	Additional Form Time (minutes)	
PM Service Technician			
Last Name	First Name	Contact #	Technician #

Fig. 4-6, PM Certification Report, Page 2

5.0 Shut Down

The Alpha XM3-HP CableUPS contains more than one live circuit. During an emergency, utility power can be disconnected at the service entrance or main electrical panel to protect emergency personnel. However, power is still present at the output. To prevent the possibility of injury to service or emergency personnel, always follow this procedure to safely shutdown the power supply.

5.1 Emergency Shutdown Procedure:

- 1 Switch Battery Breaker OFF.
- 2 Unplug the AC Input Line Cord from the service entrance.
- 3 Unplug both the Output 1 and Output 2 connections and N+1 connection if applicable.

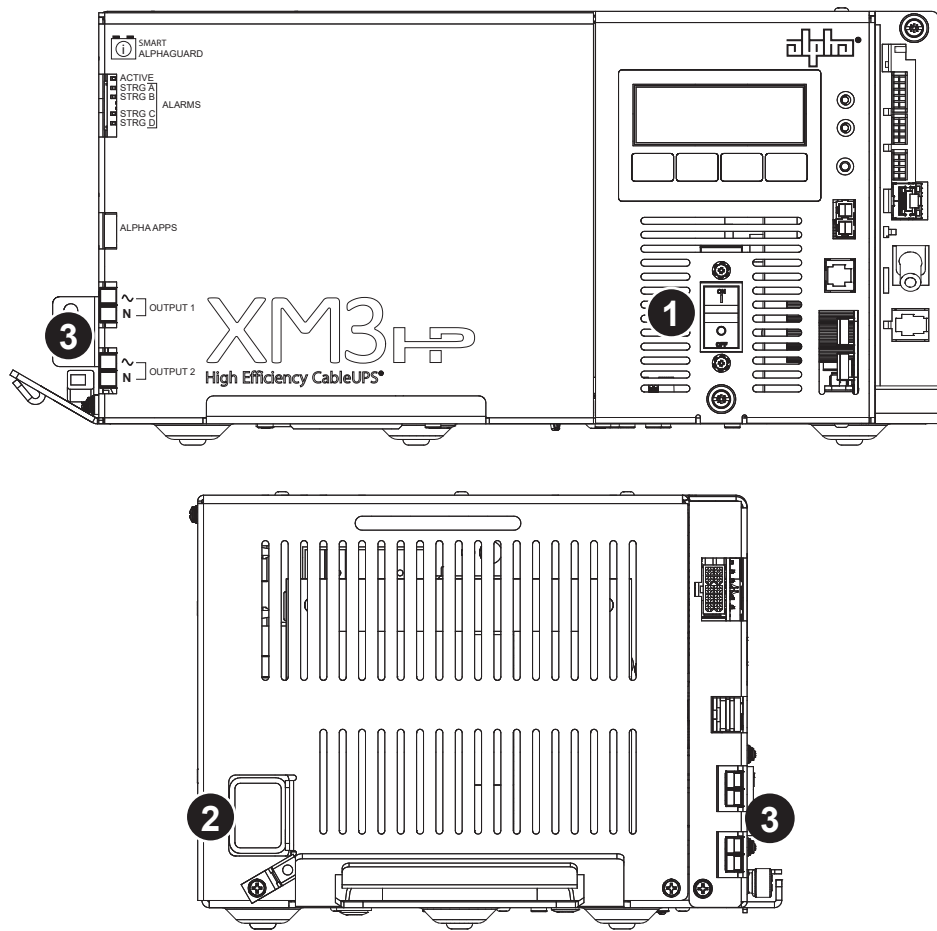

Fig. 5-1, Emergency Shutdown

6.0 Specifications

6.1 Specifications (Alpha XM3-HP CableUPS North American Models)

North American Models:	XM3-908-HP	XM3-910-HP	XM3-915-HP	XM3-918-HP	XM3-918D-HP
Fine Mode Parameters					
Nominal AC Input Voltage	120VAC	120VAC	120VAC, 240VAC (Factory Ordered)	120VAC, 240VAC (Factory Ordered)	120VAC, 240VAC (Internally Selectable)
Nominal Input Frequency	60Hz	60Hz	60Hz	60Hz	60Hz
Input Frequency Tolerance (%)	±3	±3	±3	±3	±3
Input Voltage Operating Range Tolerance (%)	-25 / +15	-25 / +15	-25 / +15	-25 / +15	-20 / +15
Input Voltage Range (VAC)	90-138	90-138	90-138, 173-276	90-138, 173-276	96-138, 192-276
Output Voltage (VAC)	63 / 89	63 / 89	63 / 89	63 / 89	63 / 89
Output Voltage Regulation (%)	-2.5 / +1	-2.5 / +1	-2.5 / +1	-2.5 / +1	-5 / +2
Maximum Rated Output Current	8 Amps	10 Amps	15 Amps	18 Amps	18 Amps
Maximum Output Power (VA)	720	900	1350	1620	1620
Line Mode Efficiency	Up to 94%				
Standby Efficiency	Up to 91%				
Output Waveform	Quasi-square wave				
Short Circuit Protection	<150% of maximum current rating				
Transfer Characteristics	Uninterrupted output				
Battery Voltage (VDC)	36	36	36	36	36
Battery Charger					
Temperature Compensation	Programmable (0 to 5mV/Cell/°C)				
Bulk Charger Current (Amps @ 80% Load & Nomline)	10A				
5 Stages	Refresh, Bulk, Accept, Float, Rest				
Mechanical					
Inverter Module	Front plug in, Hot swappable Inverter Module				
Dimensions H x W x D (in/mm)	7.8 x 15 (16.7 w/handle) x 10 (10.7 w/handle) / 198.1 x 381 (424.18 w/handle) x 254 (271.8 w/handle)				
Weight (lb/kg)	48.5 / 22.0	49 / 22.3	60 / 27.2	60.5 / 27.5	69.4 / 31.5
Input Power Connector (IEC 320/C20)	NEMA 5-15P Plug	NEMA 5-15P Plug	NEMA 5-20P/ NEMA 6-15P Plug	NEMA 5-20P/ NEMA 6-15P Plug	NEMA 5-20P/ NEMA 6-15P Plug
Battery Connector	Anderson style 75A				
Remote Temp Sensor	Ring lug fastens to negative terminal on center battery				
Display	4 line by 20 character blue LCD with soft-key menu controls				
Environment					
Operating Temperature	-40 to 140°F / -40 to 60°C (derate by 3.6°F / 2°C per 1000 feet above 3000 feet)				
Humidity	0 to 95% non-condensing (relative)				
Agency Compliance					
Safety	CSA/UL 60950-1 (2nd), UL 1778 (4th) CSA No 107.3, C/US				
EMC	FCC Part 15 Class A				

Table A-1, North American Specifications

6.0 Specifications, Continued

6.2 Specifications (Alpha XM3-HP CableUPS International Models)

International Models:	XM3-915M-HP	XM3-915P-HP	XM3-910E-HP	XM3-915E-HP	XM3-615CE-HP	XM3-622CE-HP	XM3-908HP	XM3-910HP	XM3-910M-HP	XM3-915HP	XM3-918HP	XM3-918D-HP
Parameters												
Nominal AC Input Voltage (VAC)	127	200-240	200-240	200-240	230	230	110-127	110-127	127	110-127	120	120/240
Nominal Input Frequency (Hz)	60	60	50	50	50	50	60	60	60	60	60	60
Input Frequency Tolerance (%)	±3	±3	±3	±3	±3	±3	±3	±3	±3	±3	±3	±3
Input Voltage Operating Range Tolerance (%)	-34 / +15	-30 / +20	-30 / +20	-30 / +20	-30 / +20	-30 / +20	-30 / +15	-30 / +15	-34 / +15	-30 / +15	-30 / +15	-20 / +15
Output Voltage (VAC)	63 / 89	63 / 89	48 / 63 / 89	63 / 89	48 / 63	63	63 / 89	63 / 89	63/89	63 / 89	63 / 89	63 / 89
Output Voltage Regulation	-5 / +1	-5 / +1	-5 / +1	-5 / +1	-6 / +1.5	-6 / +1.5	-5 / +1	-5 / +1	-5 / +1	-5 / +1	-5 / +1	-5 / +2
Maximum Rated Output Current (Amps)	15	15	15 / 15 / 10	22 / 15	15	22	8	10	10	15	18	18
Maximum Output Power (VA)	1350	1350	900	1350	900	1408	720	900	900	1350	1620	1620
Line Mode Efficiency (%)	Up to 94											
Standby Efficiency (%)	Up to 91											
Bulk Charger Current (Amps @ 80% Load & Nom line)	10	10	10	10	10	10	10	10	10	10	10	10
Battery Voltage (VDC)	36	36	36	36	36	36*	36	36	36	36	36	36

Mechanical												
Inverter Module	Front plug in, Hot swappable Inverter Module											
Dimensions H x W x D (in/mm)	7.8 x 15 (16.7 w/handle) x 10 (10.7 w/handle) / 198.1 x 381 (424.18 w/handle) x 254 (271.8 w/handle)											
Weight (lb/kg)	60 / 27.2	60 / 27.2	53 / 24.1	67 / 30.5	53 / 24.1	67 / 30.5	48.5/22.0	49 / 22.3	49 / 22.3	60 / 27.2	60.5/27.5	69.4 31.5
Input Power Connector	IEC 320/C20											
Battery Connector	Anderson style 75A											
Remote Temp Sensor	Ring lug fastens to negative terminal on center battery											
Display	4 Line by 20 Character LCD with soft-key menu controls											
LRI Connector	Anderson PP30											
Mounting	Shelf mounts inside suitably rated electrical enclosure											
Environment												
Operating Temperature (°C/°F)	-40° to +60°/ -40° to +140° (derate by 2° to 3.6° per 1000 feet above 3000 feet)											
Storage Temperature (°C/°F)	-40° to +70°/ -40° to +158°											
Humidity (%)	0–95 non-condensing (relative)											
Conformal Coating	All Printed Circuit Board assemblies to prevent moisture related failure											

Safety Compliance												
UL/CSA 60950-1, UL 1778, CSA 107.3 (NRTL/C)	Y	Y					Y	Y	Y	Y	Y	Y
IEC 60950-1 (CB)	Y	Y	Y	Y	Y	Y	Y	Y	Y	Y	Y	Y
IEC/EN 62040-1					Y	Y						
Safety Mark	NRTL/C	NRTL/C			CE	CE	NRTL/C BSMI <i>(optional)</i>	NRTL/C	NRTL/C	NRTL/C BSMI <i>(optional)</i>	NRTL/C	NRTL/C
EMC Compliance												
FCC Part 15 Class A, ICES 003	Y	Y					Y	Y	Y	Y	Y	Y
IEC/EN 50083-2 (CATV)					Y	Y						
IEC/EN 62040-2 (UPS)			Y	Y	Y	Y						
CISPR22			Y	Y	Y	Y						

Table A-2, International Specifications

6.0 Specifications, Continued

6.3 Safety and EMC Compliance

The Alpha XM3-HP CableUPS is certified over a wide range of North American and International safety and EMC specifications as indicated below.

Model	Input VAC	Safety Certification	EMI/EMC
XM3-908/910/915-HP	110-127V 60Hz	UL/CSA 60950-1, UL 1778, CSA 107.3 BSMI (for 908/915)	FCC CFR47 Part 15 Class A, ICES-003, BSMI
XM3-918-HP/918D-HP	120V 60Hz / 240V 60Hz (918D-HP only)	UL/CSA 60950-1, UL 1778, CSA 107.3	FCC CFR47 Part 15 Class A ICES-003
XM3-910M/915M-HP	127V 60Hz	CB Report, IEC/EN 60950-1: Ed. 2	CISPR 22 Class A
XM3-915P-HP	200-240V 60Hz	CB Report, IEC/EN 60950-1: Ed. 2	CISPR 22 Class A
XM3-910E-HP	200-240V 50Hz	CB Report, IEC/EN 60950-1: Ed. 2	CISPR 22 Class A
XM3-915E-HP	200-240V 50Hz	CB Report, IEC/EN 60950-1: Ed. 2	CISPR 22 Class A
XM3-615CE-HP	230V 50Hz	CE, CB Report IEC/EN 60950-1 Ed. 2, EN 62040-1, EN 60728-11	EN62040-2 (UPS Equipment), EN50083-2 (CATV Equipment) Category C2
XM3-622CE-HP	230V 50Hz	CE, CB Report IEC/EN 60950-1 Ed. 2, EN 62040-1, EN 60728-11	EN62040-2 (UPS Equipment) EN50083-2 (CATV Equipment) Category C2

Table A-3, Product Certifications Regarding Safety, EMC Compliance

6.4 Simplified Block Diagram

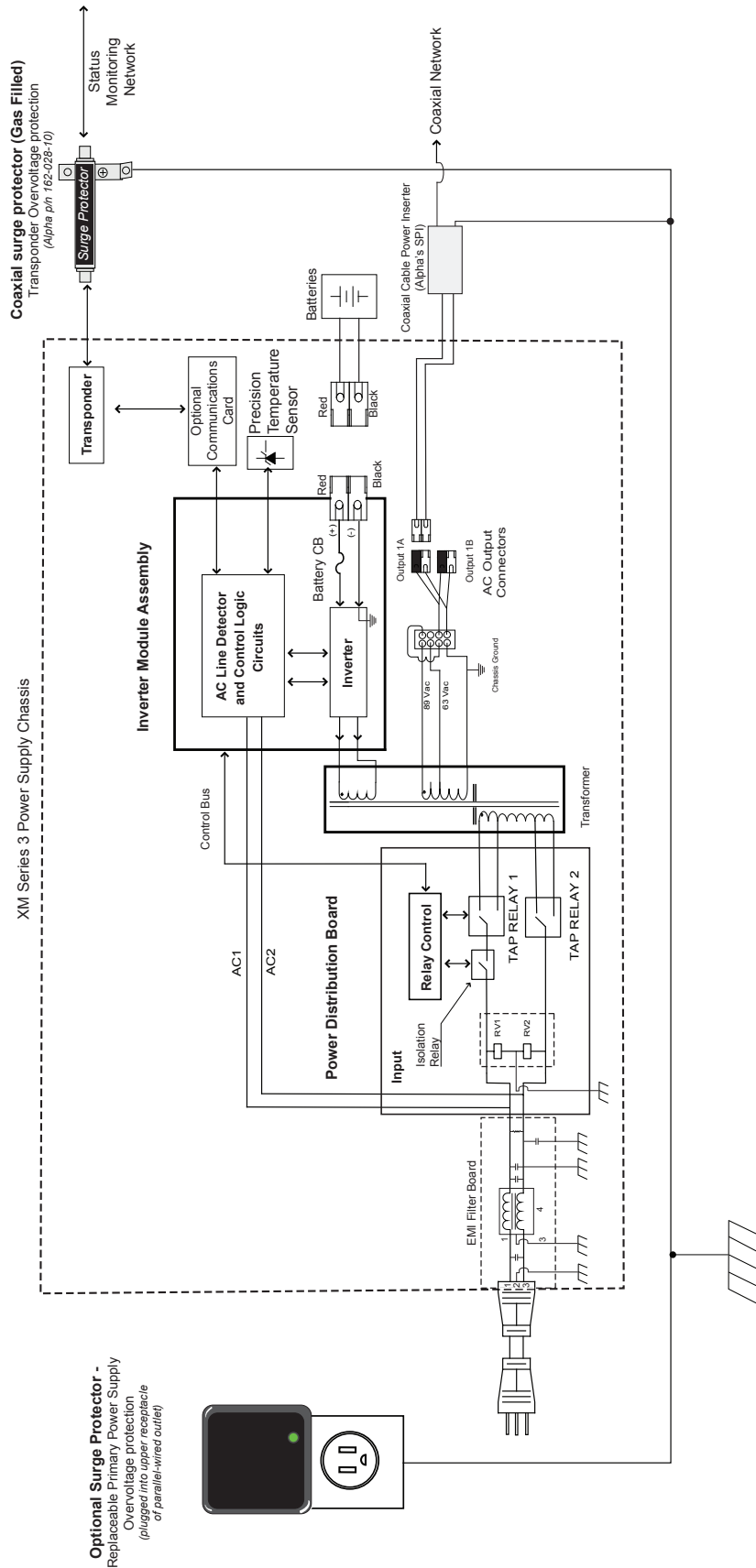

Fig. A-1, Block Diagram

6.0 Specifications, Continued

6.5 System Options

These options can be factory installed or upgraded in the field by the user:

Local and Remote Indicator (LRI)

The red LRI lamp is located on the outside of pole-mount enclosures. Using this simple form of status monitoring operators can check the operational status of the power supply without having to climb the pole and open the enclosure. During normal AC line operation, the LRI remains off. The LRI comes on only when the power supply is running in standby mode. Whenever a fault is detected during Self Test, the LRI flashes to indicate that service is required.

AC Indicator (ACI)

The green ACI lamp is located next to the LRI on the outside of pole-mount enclosures and also acts as a simple form of status monitoring so cable technicians can check the output status of the power supply without having to climb the pole and open the enclosure. As long as there is voltage present at the output, the ACI remains on. To provide much longer life than the original light bulb design, use the ACI-LL (long life LED). Models for 60V and 90V are available. Do not use ACIs for ground-mount enclosures.

Coaxial Surge Arrestor

Alpha recommends using coaxial surge suppression for enclosure protection. The Coax Surge Protector (Alpha P/N 162-028-10) includes 75 ohm surge suppressor and mounting hardware.

APP90S/APP9022S (Service Power Supply)

The APP90S/APP9022S is a portable, non-standby power supply that provides conditioned AC power to the load when the main power module is out of service. An internal tap lets the APP90S/APP9022S be set for 90/75/60VAC applications. Use a 15A or 25A SPI (Service Power Inserter) to transfer power from the APP9015S/APP9022S to the load.

6.6 Return and Repair Information

In the event you need to return the power supply to Alpha Technologies for service, a Return Material Authorization (RMA) form must accompany the unit. The form can be found at Alpha's Web site (www.alpha.com/rma). Follow the instructions contained in the form to obtain an RMA. Once an RMA number has been issued, pack the unit per instructions and return to the service center assigned by Alpha Technologies. Or, if preferred, contact Alpha Technologies at (800) 322-5742 for assistance.



NOTICE:

Any information pertaining to the nature of the power supply failure or problem, along with a copy of the power supply's maintenance log, should be included with the returned power supply.



Worldwide Corporate Offices

North America

Tel: +1 360 647 2360
Fax: +1 360 671 4936

Europe

Tel: +49 9122 79889 0
Fax: +49 9122 79889 21

Latin America

Tel: +561 792.9651
Fax: +561 792.7157

Asia Pacific

Tel: +852 2736.8663
Fax: +852 2199.7988